

A. 主体関係 / Machine body / Maschinengeh use / Corps de la machine / Cuerpo de la maquina

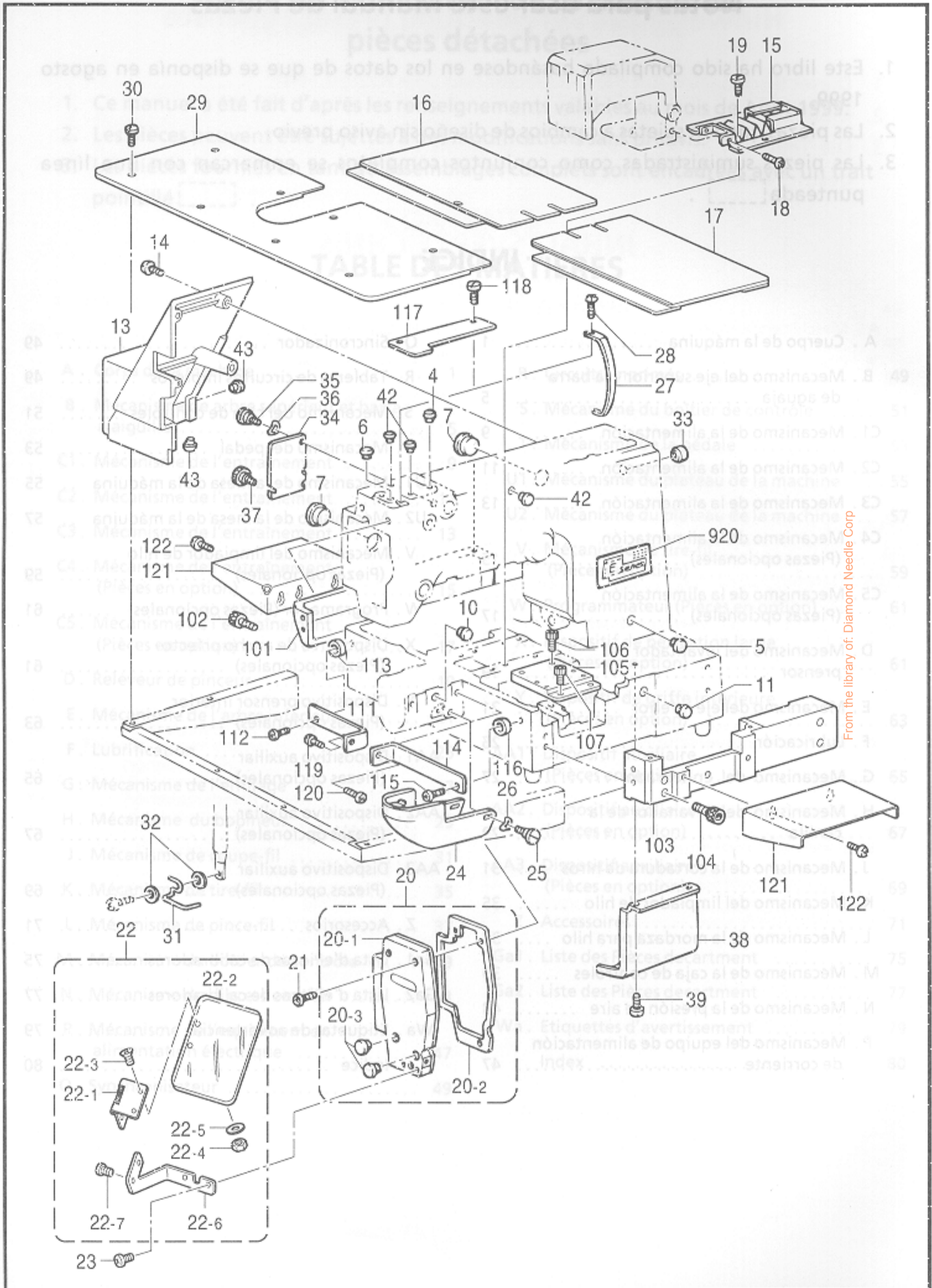

A. 主体関係 / Machine body / Maschinengehäuse / Corps de la machine / Cuerpo de la máquina

REF.NO.	CODE	Q'TY	ヒンメイ	NAME OF PARTS	RM
4	104450109	1	ゴムセン8	RUBBER CAP, 8	
5	117934009	1	ゴムセン13.5	RUBBER CAP, 13.5	
6	117934009	1	ゴムセン13.5	RUBBER CAP, 13.5	
7	140392009	2	オイルフタ	OIL CAP	
10	104450109	1	ゴムセン8	RUBBER CAP, 8	
11	117934009	1	ゴムセン13.5	RUBBER CAP, 13.5	
13	S44309109	1	ソクメンカバー	FRAME SIDE COVER	
14	062711212	4	ナベコ476-32X12	SCREW, PAN SM4.76-32X12	
15	S44313001	1	ジヤバラクミ	BELLOW ASSY	
16	S48534009	1	XオクリダイカバーLクミ	X-FEED BRACKET COVER ASSY, L	
17	S48537009	1	XオクリダイカバーRクミ	X-FEED BRACKET COVER ASSY, R	
18	062680612	2	ナベコ4.37-40X6	SCREW, PAN SM4.37-40X6	
19	106629002	4	シメネジ4.37	SCREW, SM4.37	
20	S42750109	1	メンイタクミ	FACE PLATE ASSY	
20-1	S42751009	1	メンイタ	FACE PLATE	
20-2	S42752000	1	メンイタバツキン	PACKING, FACE PLATE	
20-3	117934009	2	ゴムセン13.5	RUBBER CAP, 13.5	
21	062711012	3	ナベコ476-32X10	SCREW, PAN SM4.76-32X10	
22	S44494001	1	アイガードクミB	EYE GUARD ASSY, B	
22-1	S44483001	1	チヨウバンクミ	HINGE ASSY	
22-2	S44485001	1	アイガード	EYE GUARD	
22-3	061660806	2	サラコ318-40X8	SCREW, FLAT SM3.18-40X8	
22-4	021660102	2	ナット1シユ3.18	NUT, 1 SM3.18	
22-5	025030232	2	ヒラザガネチユウ3	WASHER, PLAIN M 3	
22-6	S44487001	1	アイガードホルダーB	EYE GUARD HOLDER, B	
22-7	062670512	2	ナベコ357-40X5	SCREW, PAN SM3.57-40X5	
23	062670612	2	ナベコ357-40X6	SCREW, PAN SM3.57-40X6	
24	S10030002	1	オオカマカバークミ	SHUTTLE RACE COVER ASSY	
25	145480101	2	ダンネジ6.35	SHOULDER SCREW, SM6.35	
26	109239002	2	ナミバネザガネ	WASHER, WAVE SPRING	
27	S37920009	1	テンピンカバー	THREAD TAKE-UP COVER	
28	062680612	1	ナベコ4.37-40X6	SCREW, PAN SM4.37-40X6	
29	S48539001	1	326Lハリイタホジヨイタ	AUXILIARY PLATE, 326L	
30	106629002	8	シメネジ4.37	SCREW, SM4.37	
31	S02445001	1	フィンガーガード	FINGER GUARD	
32	025350332	2	ヒラザガネダイ3.5	WASHER, PLAIN L 3.5	
33	S20164009	1	ゴムセン13	RUBBER CAP, 13	
34	S17803001	1	カンケツカバー	STEPPING COVER	
35	107321003	1	ダンネジ4.76	SHOULDER SCREW, SM4.76	
36	107017002	1	ナミバネザガネ	WASHER, WAVE SPRING 6.45	
37	129986001	1	ツマミネジ3.57	SCREW, SM3.57	
38	S42758001	1	SOLアブラウケ	OIL PAN, SOL	
39	062400612	2	ナベコM4X6	SCREW, PAN M4X6	
42	117936009	3	ゴムセン9.4	RUBBER CAP, 9.4	
43	104450109	2	ゴムセン8	RUBBER CAP, 8	
101	S44317009	1	ベッド326L	BED, 326 L	
102	018082022	4	アナボルト8X20	BOLT, SOCKET M8X20	
103	S48540109	1	ベッド326EL-R	BED, 326EL-R	
104	018082022	4	アナボルト8X20	BOLT, SOCKET M8X20	
105	S44606001	1	XプーリダイスペーサL	SPACER	
106	018501622	2	アナボルト5X16	BOLT, SOCKET M5X16	
107	018501222	2	アナボルト5X12	BOLT, SOCKET M5X12	
111	S44320001	1	ベッドカバーLF	BED COVER, LF	
112	062681212	1	ナベコ437-40X12	SCREW, PAN SM4.37-40X12	
113	S19736001	1	カラー4.5	COLLAR, 4.5	
114	S44321001	1	ベッドカバーRF	BED COVER, RF	
115	062681212	1	ナベコ437-40X12	SCREW, PAN SM4.37-40X12	
116	S19736001	1	カラー4.5	COLLAR, 4.5	
117	S44387009	1	ベッドカバーLR	BED COVER, LR	

From the library of: Diamond Needle Corp

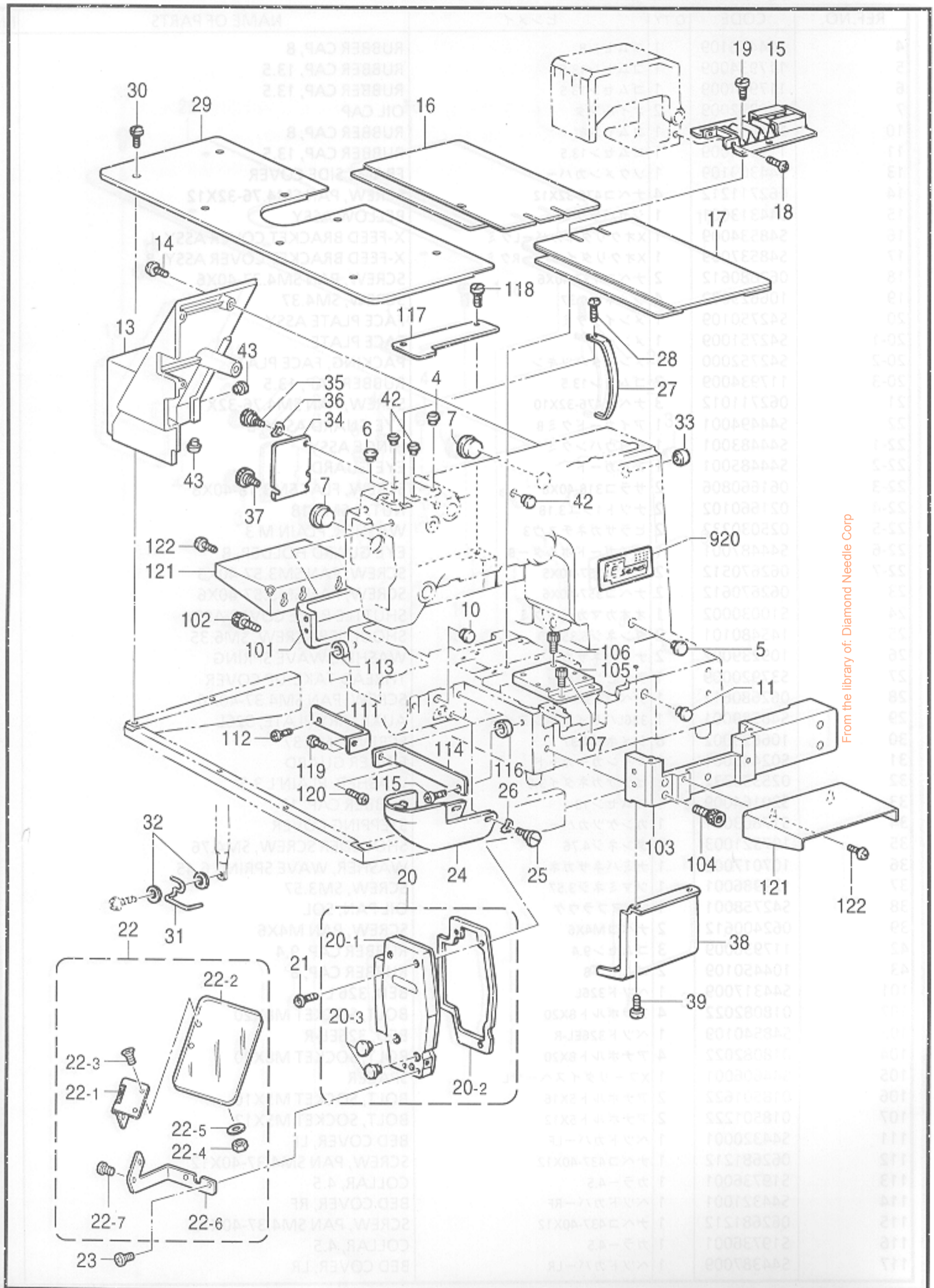

A. 主体関係 / Machine body / Maschinengehäuse / Corps de la machine / Cuerpo de la máquina

REF.NO.	CODE	Q'TY	ヒンメイ	NAME OF PARTS	RM
118	106629002	2	シメネジ4.37	SCREW, SM4.37	
119	062680812	1	ナベコ437-40X8	SCREW, PAN SM4.37-40X8	
120	062680812	1	ナベコ437-40X8	SCREW, PAN SM4.37-40X8	
121	S44322101	2	オクリダイカバーササエ	COVER SUPPORT, F-BRACKET	
122	062761012	4	ナベコ595-28X10	SCREW, PAN SM5.95-28X10	
920	S44629001	1	Eマーク	LABEL, E	
	072622000	1	ボールベアリング6302VV	BALL BEARING, 6302VV	
	048150142	1	リテーニングリング外部C15	RETAINING RING, EXTERNAL C15	
	S38035109	1	プーリーアッシー	PULLEY ASSY	
	S47698252	2	アタメネジ5.95	SET SCREW, SOCKET SM5.95	
10-1	S2231000	1	スレッドアップクランク	THREAD TAKE-UP CRANK	
11	S02250001	1	シメネジ7.14	SCREW, SM7.14	
12	S14770622	2	アタメネジ6.35クボミ	SET SCREW, SOCKET (CP) SM6.35	
13-1	S07296001	1	シメネジ6.35	SET SCREW, SM6.35	
14-1	S43394001	1	スレッドアップレバーセット	THREAD TAKE-UP LEVER SET	
14-1-1	S43392001	1	スレッドアップレバーアッシー	THREAD TAKE-UP LEVER ASSY	
14-1-2	S33396001	1	スレッドアップサポートシャフト	THREAD TAKE-UP SUPPORT SHAFT	
14-1-3	S52237101	1	ニードルバークランクA	NEEDLE BAR CRANK, A	
14-1-4	S32051001	1	ナベコ3.57U	SCREW, FLAT SM3.57 U	
14-1-5	S43393001	1	ニードルバー接続ロッド	NEEDLE BAR CONNECTING ROD	
14-1-6	S42275001	1	ニードルバー	NEEDLE BAR	
14-1-7	S62290712	1	ナベコ437-40X7	SCREW, PAN SM4.37-40X7	
15	S14770622	1	アタメネジ6.35クボミ	SET SCREW, SOCKET (CP) SM6.35	
16	102629001	1	ハリボウアンナイカクコ	SLIDE BLOCK, N-BAR GUIDE	
17	S32232000	1	ハリボウアンナイ	NEEDLE BAR GUIDE	
18	100232003	2	シメネジ3.57	SCREW, SM3.57	
19	S59597000	2	ゴムパッキン	RUBBER GASKET	
20	S42275001	1	ハリボウ	NEEDLE BAR	
21	S42275001	1	アタメネジ3.57	SET SCREW, SM3.57	
22	S52237101	1	ハリボウメタルU	NEEDLE BAR BUSH, U	
23	S52237101	1	ハリボウメタルD	NEEDLE BAR BUSH, D	
24	107415016	1	ニードルDPX5(#16)	NEEDLE, DPX5 (#16)	
24	145646021	1	ニードルDPX17(#21)	NEEDLE, DPX17 (#21)	
10-2	S4623000	1	スレッドアップクランクB	THREAD TAKE-UP CRANK B	
11	100250001	1	シメネジ7.14	SCREW, SM7.14	
12	S14770622	2	アタメネジ6.35クボミ	SET SCREW, SOCKET (CP) SM6.35	
13-2	S23006001	1	アタメネジ6.35クボミ	SET SCREW, SOCKET (CP) SM6.35	
14-2	S43394001	1	スレッドアップレバーセット	THREAD TAKE-UP LEVER SET	
14-2-1	S43392001	1	スレッドアップレバーアッシー	THREAD TAKE-UP LEVER ASSY	
14-2-2	S52237101	1	スレッドアップサポートシャフト	THREAD TAKE-UP SUPPORT SHAFT	
14-2-3	S43393001	1	ニードルバークランクB	NEEDLE BAR CRANK, B	
14-2-4	S32051001	1	ナベコ3.57L	SCREW, FLAT SM3.57 L	
14-2-5	S43393001	1	ニードルバー接続ロッド	NEEDLE BAR CONNECTING ROD	
14-2-6	S42275001	1	ハリボウダキ	CLAMP, NEEDLE BAR	
14-2-7	S62290712	1	ナベコ437-40X7	SCREW, PAN SM4.37-40X7	
24	107415009	1	ニードルDPX9(#9)	NEEDLE, DPX9 (#9)	
24	107415011	1	ニードルDPX11(#11)	NEEDLE, DPX11 (#11)	
24	107415014	1	ニードルDPX14(#14)	NEEDLE, DPX14 (#14)	
24	107415018	1	ニードルDPX18(#18)	NEEDLE, DPX18 (#18)	
24	107415019	1	ニードルDPX19(#19)	NEEDLE, DPX19 (#19)	
24	107415021	1	ニードルDPX21(#21)	NEEDLE, DPX21 (#21)	

From the library of: Diamond Needle Corp

B. 上軸・針棒関係 / Upper shaft and needle bar mechanism / Obere Welle und Nadelstangenvorrichtung
 / M canisme de arbre sup rieur et barra aiguille / Mecanismo del eje superior y la barra de aguja

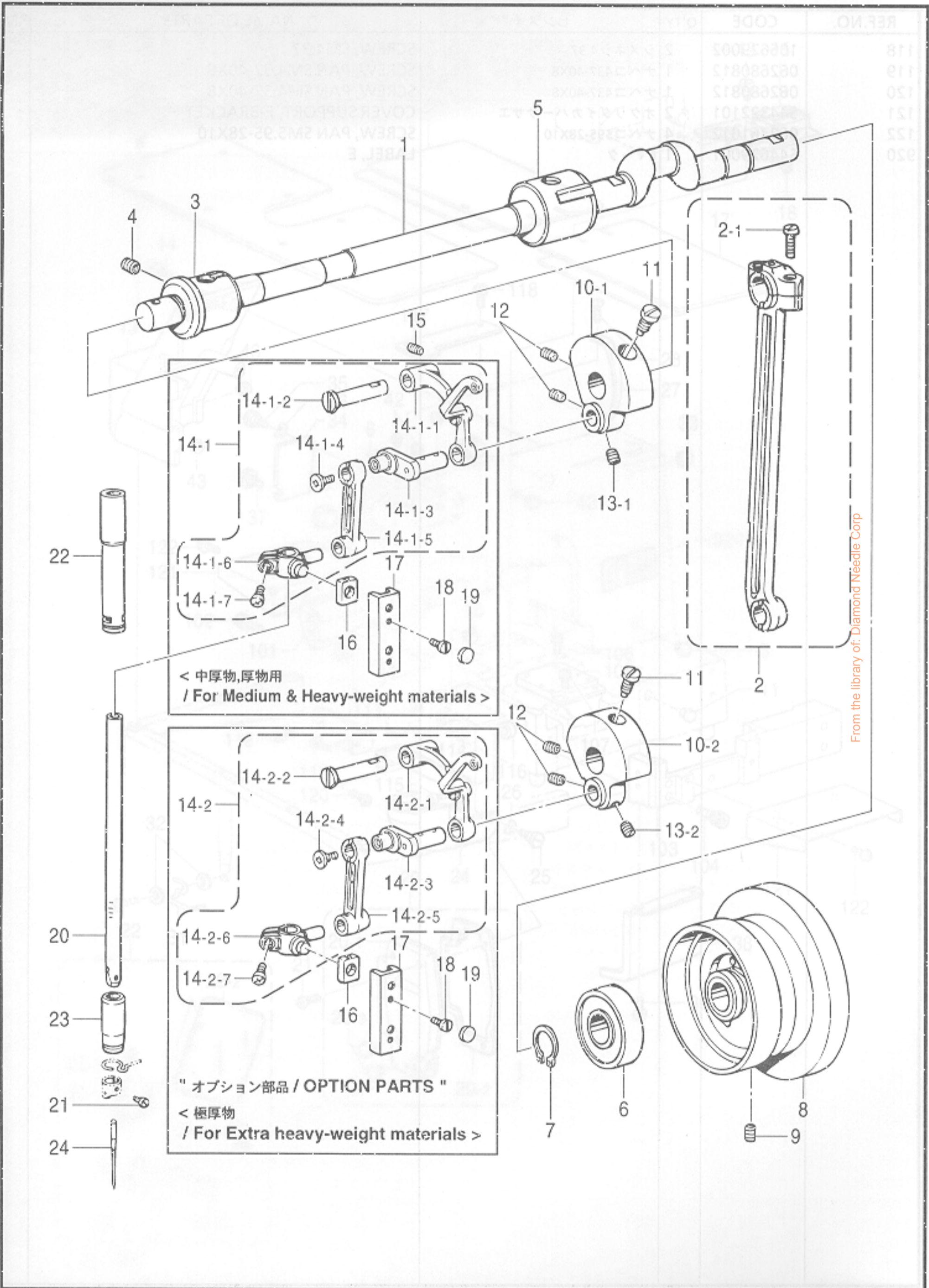

B. 上軸・針棒関係 / Upper shaft and needle bar mechanism / Obere Welle und Nadelstangenvorrichtung
 / Mécanisme de arbre supérieur et barra à aiguille / Mecanismo del eje superior y la barra de aguaja

REF.NO.	CODE	Q'TY	品名	NAME OF PARTS	RM
1	S42830001	1	ウワジク	UPPER SHAFT	
2	S45147001	1	クランクロッドクミ	CRANK ROD ASSY	
2-1	144712001	2	シメネジ4.76	SCREW, SM4.76	
3	S42754001	1	ウワジクメタルL	UPPER SHAFT BUSH, L	
4	014780622	1	アナトメネジ6.35クボミ	SET SCREW, SOCKET (CP) SM6.35	
5	140726000	1	ウワジクメタルM	UPPER SHAFT BUSH, M	
6	072630260	1	ベアリング6302VV	BALL BEARING, 6302VV	
7	048150142	1	トメワジクヨウC15	RETAINING RING, EXTERNAL C15	
8	S38035109	1	プーリクミ	PULLEY ASSY	
9	014760622	2	アナトメネジ5.95	SET SCREW, SOCKET SM5.95	
10-1	152231000	1	ツリアイクランク	THREAD TAKE-UP CRANK	
11	100250001	1	シメネジ7.14	SCREW, SM7.14	
12	014770622	2	アナトメネジ6.35クボミ	SET SCREW, SOCKET (CP) SM6.35	
13-1	101706001	1	トメネジ6.35	SET SCREW, SM6.35	
14-1	S43984001	1	ハリボウレンカンクミ	THREAD TAKE-UP LEVER SET	
14-1-1	S43982001	1	テンピンクミ	THREAD TAKE-UP LEVER ASSY	
14-1-2	152236001	1	テンピンササエジク	THREAD TAKE-UP SUPPORT SHAFT	
14-1-3	152237101	1	ハリボウクランク	NEEDLE BAR CRANK	
14-1-4	132051001	1	+サラネジ3.57L	SCREW, FLAT SM3.57 L	
14-1-5	S43689001	1	ハリボウレンカン	NEEDLE BAR CONNECTING ROD	
14-1-6	S42756001	1	ハリボウダキ	CLAMP, NEEDLE BAR	
14-1-7	062680712	1	ナベコ437-40X7	SCREW, PAN SM4.37-40X7	
15	014780622	1	アナトメネジ6.35クボミ	SET SCREW, SOCKET (CP) SM6.35	
16	102630001	1	ハリボウアンナイカクコマ	SLIDE BLOCK, N-BAR GUIDE	
17	S37927000	1	ハリボウアンナイ	NEEDLE BAR GUIDE	
18	100242003	2	シメネジ3.57	SCREW, SM3.57	
19	155578000	2	ゴムセン7.2	RUBBER CAP, 7.2	
20	S02269001	1	ハリボウ	NEEDLE BAR	
21	144458001	1	アタマツキトメネジ3.57	SET SCREW, SM3.57	
22	152242001	1	ハリボウメタルU	NEEDLE BAR BUSH, U	
23	152243001	1	ハリボウメタルD	NEEDLE BAR BUSH, D	
24	107415016	1	<中厚物用> ミシンハリDPX5	<For Medium-weight materials> NEEDLE, DPX5 (#16)	
24	145646021	1	<厚物用> ミシンハリDPX17	<For Heavy-weight materials> NEEDLE, DPX17 (#21)	
			" オプション部品 "	" OPTION PARTS "	
10-2	154623000	1	<極厚物用> ツリアイクランクB	<For Extra heavy-weight materials> THREAD TAKE-UP CRANK, B	
11	100250001	1	シメネジ7.14	SCREW, SM7.14	
12	014770622	2	アナトメネジ6.35クボミ	SET SCREW, SOCKET (CP) SM6.35	
13-2	123006001	1	トメネジ6.35クボミ	SET SCREW, (CP) SM6.35	
14-2	S43985001	1	ハリボウレンカンBクミ	THREAD TAKE-UP LEVER SET, B	
14-2-1	S43982001	1	テンピンクミ	THREAD TAKE-UP LEVER ASSY	
14-2-2	152236001	1	テンピンササエジク	THREAD TAKE-UP SUPPORT SHAFT	
14-2-3	154624101	1	ハリボウクランクB	NEEDLE BAR CRANK, B	
14-2-4	132051001	1	+サラネジ3.57L	SCREW, FLAT SM3.57 L	
14-2-5	S43689001	1	ハリボウレンカン	NEEDLE BAR CONNECTING ROD	
14-2-6	S42756001	1	ハリボウダキ	CLAMP, NEEDLE BAR	
14-2-7	062680712	1	ナベコ437-40X7	SCREW, PAN SM4.37-40X7	
24	107415009	1	ミシンハリDPX5	NEEDLE, DPX5 (#9)	
24	107415011	1	ミシンハリDPX5	NEEDLE, DPX5 (#11)	
24	107415014	1	ミシンハリDPX5	NEEDLE, DPX5 (#14)	
24	107415018	1	ミシンハリDPX5	NEEDLE, DPX5 (#18)	
24	107415019	1	ミシンハリDPX5	NEEDLE, DPX5 (#19)	
24	107415021	1	ミシンハリDPX5	NEEDLE, DPX5 (#21)	

From the library of: Diamond Needle Corp

B. 上軸・針棒関係 / Upper shaft and needle bar mechanism / Obere Welle und Nadelstängenvorrichtung
 / M canisme de arbre sup rieur et barra aiguille / Mecanismo del eje superior y la barra de agujaja

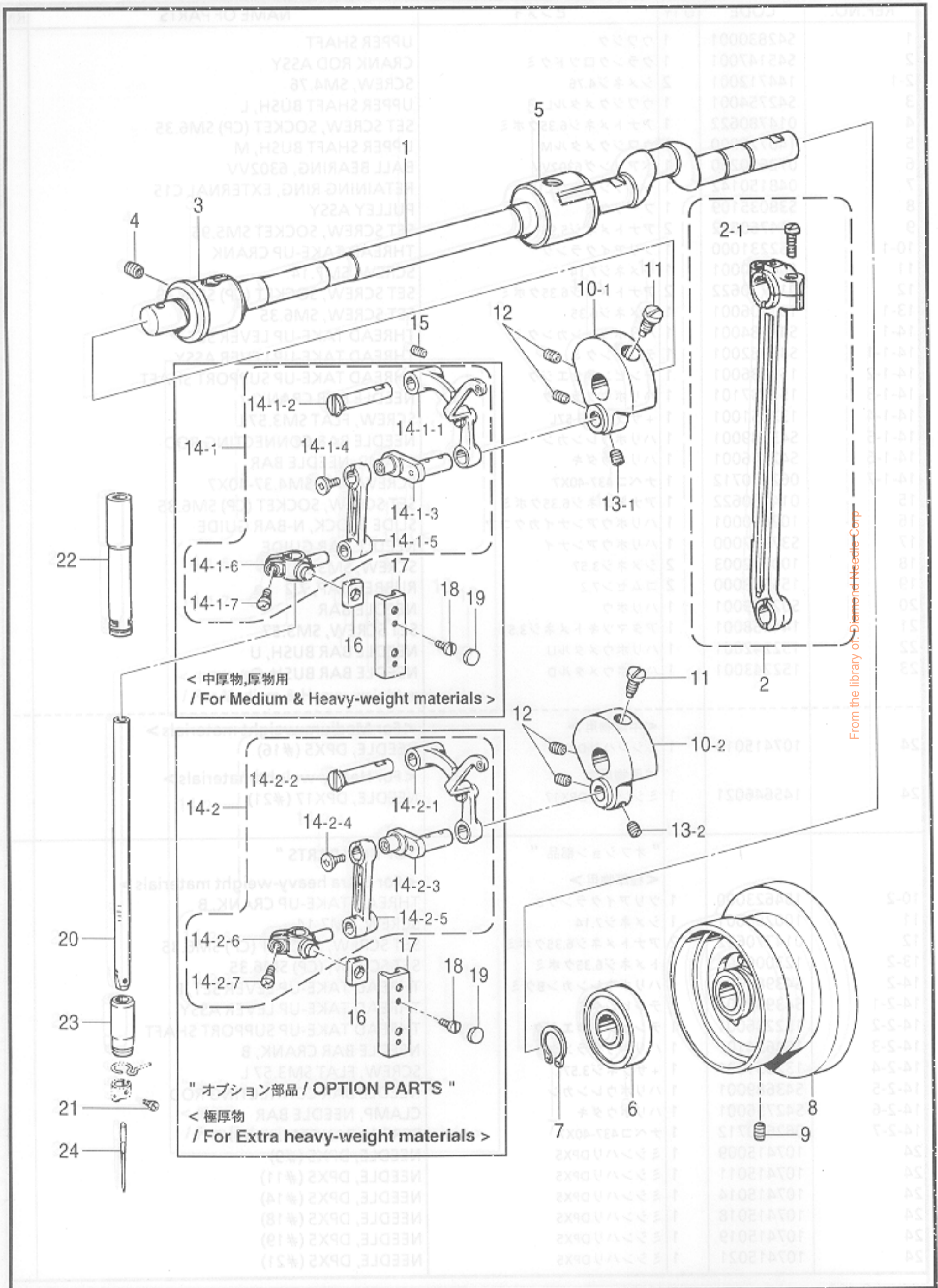

B. 上軸・針棒関係 / Upper shaft and needle bar mechanism / Obere Welle und Nadelstangenvorrichtung
 / Mécanisme de arbre supérieur et barra à aiguille / Mecanismo del eje superior y la barra de aguaja

REF.NO.	CODE	Q'TY	ヒンメイ	NAME OF PARTS	RM
24	107415023	1	ニシンハリDPX5	NEEDLE, DPX5 (#23)	
24	154763010	1	ニシンハリDPX5KN	NEEDLE, DPX5KN (#10)	
24	S37929009	1	ニシンハリDPX5NY	NEEDLE, DPX5NY (#9)	
24	S37929016	1	ニシンハリDPX5NY	NEEDLE, DPX5NY (#16)	
24	145646011	1	ニシンハリDPX17	NEEDLE, DPX17 (#11)	
24	145646014	1	ニシンハリDPX17	NEEDLE, DPX17 (#14)	
24	145646016	1	ニシンハリDPX17	NEEDLE, DPX17 (#16)	
24	145646018	1	ニシンハリDPX17	NEEDLE, DPX17 (#18)	
24	145646019	1	ニシンハリDPX17	NEEDLE, DPX17 (#19)	
24	145646024	1	ニシンハリDPX17	NEEDLE, DPX17 (#24)	
24	145646025	1	ニシンハリDPX17	NEEDLE, DPX17 (#25)	
24	S37928019	1	ニシンハリDPX17NY	NEEDLE, DPX17NY (#19)	
24	S24511007	1	ニシンハリ3355-01MR	NEEDLE, 3355-01 MR7 (#7)	
-14	S17813001	2	イサエアゲ	EVERAD	
-15	S44329001	1	イサエアゲテンジク	WORK CLAMP LIES FOR SHAFT	
-16	S48050342	1	メワES	RETAINING RING #5	
-17	S43591001	1	ニシンハリ	RING, T-#10	
-18	S21775001	1	ニシンハリ	SET SCREW COLLAR ASSY	
-18-1	S13900101	1	ニシンハリ	SET SCREW COLLAR	
-18-2	S13900102	2	ニシンハリ	SET SCREW COLLAR (CP) SM4.37	
-19	S14760622	1	ニシンハリ	SET SCREW SOCKET SM5.95	
-20	S14760622	2	ニシンハリ	BOLT, SOCKET M4X8	
-21	S025040132	2	ニシンハリ	WASHER, PLAIN S 4	
-22	S4900000	1	ニシンハリ	SUPPORT SHAFT	
-23	S18000001	1	ニシンハリ	SPRING	
-24	S014760622	1	ニシンハリ	SET SCREW, SOCKET SM5.95	
	S17815000	1	ニシンハリ	SLIDER	
	S01029001	1	ニシンハリ	SUPPORT PLATE	
	S140482001	2	ニシンハリ	BOLT, FLANGE/SOCKET M6X15	
	S051030001	1	ニシンハリ	WORK CLAMP, R 326L	
	S051031001	1	ニシンハリ	WORK CLAMP, L 326L	
	S025680232	2	ニシンハリ	WASHER, PLAIN S 37	
	S15300002	2	ニシンハリ	BOLT, SM4.37X7	
	S10065001	2	ニシンハリ	POSITIONING PLATE	
	S062680512	2	ニシンハリ	SCREW, PAN SM4.37 40X5	
	S044433201	1	ニシンハリ	ROD BRACKET #557, 326	
	S044437201	1	ニシンハリ	X-FEED BRACKET	
	S044434001	2	ニシンハリ	X-FEED GUIDE ASSY, 326	
	S018680822	4	ニシンハリ	BOLT, SOCKET SM4.37X8	
	S044436000	1	ニシンハリ	CROSS ROLLER, 326	
	S044437001	1	ニシンハリ	X-FEED BRACKET	
	S0044000	1	ニシンハリ	SCREW, FLAT M4X8	
	S014770102	2	ニシンハリ	BOLT, SM5.95X14	
	S025060132	2	ニシンハリ	WASHER, PLAIN S 6	
	S018680822	2	ニシンハリ	BOLT, SOCKET SM4.37X8	

From the library of: Diamond Needle Corp

C1. 送り関係 / Feed mechanism / Transportvorrichtung / M canisme de l'«entra nement
 / Mecanismo de la alimentaci n

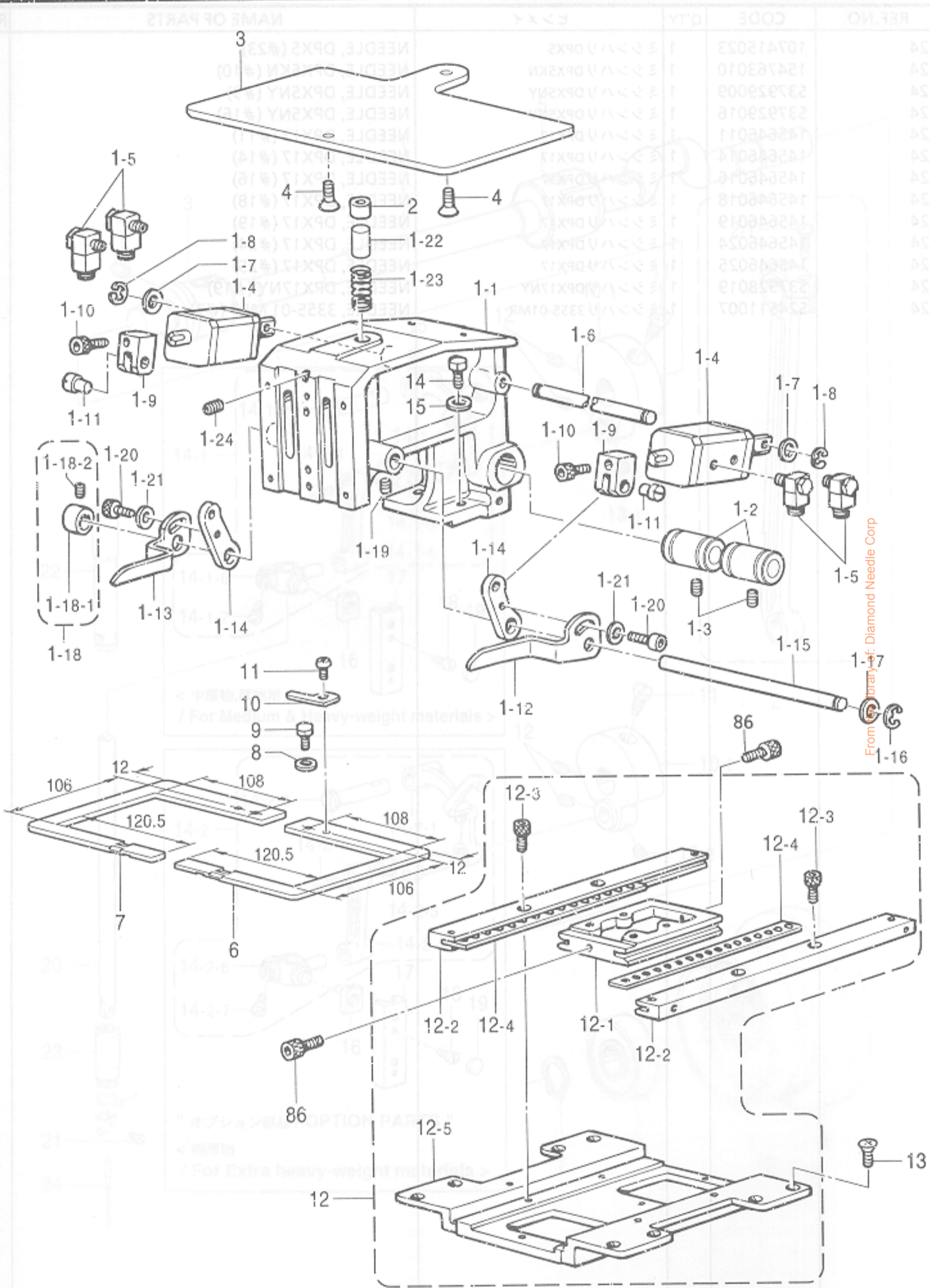

From the library of: Diamond Needle Corp

C1. 送り関係 / Feed mechanism / Transportvorrichtung / Mécanisme de l'entraînement
/ Mecanismo de la alimentación

REF.NO.	CODE	Q'TY	ヒンメイ	NAME OF PARTS	RM
1	S51027001	1	オサエウデクミ	WORK CLAMP ARM ASSY	
1-1	S51028000	1	オサエウデ	WORK CLAMP ARM	
1-2	S35183000	2	リニアブツシユ12	LINEAR BUSH, 12	
1-3	011679312	2	トメネジ3.57ヒラ	SET SCREW, (FT) SM3.57	
1-4	S30950000	2	フラットシリンダ	FLAT CYLINDER	
1-5	S18539000	4	エルボM5-05	ELBOW, M5-05	
1-6	S44326001	1	エアシリンダササエジク	SUPPORT SHAFT	
1-7	146354001	2	ザガネ	WASHER, PLAIN 5	
1-8	048040342	2	トメワE4	RETAINING RING, E4	
1-9	S30951001	2	シリンダツギテ	CYLINDER JOINT	
1-10	018401622	2	アナボルト4X16	BOLT, SOCKET M4X16	
1-11	110168001	2	コロジク	ROLLER SHAFT	
1-12	S44327001	1	オサエアゲレバーUR	WORK CLAMP LIFTER LEVER, UR	
1-13	S44328001	1	オサエアゲレバーUL	WORK CLAMP LIFTER LEVER, UL	
1-14	S17813001	2	オサエアゲレバーD	LEVER, D	
1-15	S44329001	1	オサエアゲシテンジク	WORK CLAMP LIFTER SHAFT	
1-16	048050342	1	トメワE5	RETAINING RING, E5	
1-17	143591001	1	スラストリング	RING, THRUST	
1-18	S21775001	1	セットカラークミ	SET SCREW COLLAR ASSY	
1-18-1	139096001	1	セットカラー	SET SCREW COLLAR	
1-18-2	014680422	2	アナトメネジ4.37クボミ	SET SCREW, SOCKET (CP) SM4.37	
1-19	014760622	1	アナトメネジ5.95	SET SCREW, SOCKET SM5.95	
1-20	018400832	2	アナボルト4X8	BOLT, SOCKET M4X8	
1-21	025040132	2	ヒラザガネシヨウ4	WASHER, PLAIN S 4	
1-22	S49419001	1	スライダササエジク	SUPPORT SHAFT	
1-23	S18636101	1	スライダーオシバネ	SPRING	
1-24	014760622	1	アナトメネジ5.95	SET SCREW, SOCKET SM5.95	
2	S17815000	1	スライダー	SLIDER	
3	S51029001	1	オサエウデササエイタ	SUPPORT PLATE	
4	149482001	2	アナツキサラボルトM6X15	BOLT, FLAT W/SOCKET M6X15	
6	S51030001	1	326LオサエR	WORK CLAMP, R 326L	
7	S51031001	1	326LオサエL	WORK CLAMP, L 326L	
8	025680232	2	ヒラザガネチユウ4.37	WASHER, PLAIN M 4.37	
9	153403002	2	ボルト4.37X7	BOLT, SM4.37X7	
10	S10065001	2	イチギメイタ	POSITIONING PLATE	
11	062680512	2	ナベコ437-40X5	SCREW, PAN SM4.37-40X5	
12	S44433201	1	326オクリダイクミ	FEED BRACKET ASSY, 326	
12-1	S44437201	1	Yオクリダイ	Y-FEED BRACKET	
12-2	S44434001	2	326Yオクリアンナイクミ	Y-FEED GUIDE ASSY, 326	
12-3	018680822	4	アナボルト4.37X8	BOLT, SOCKET SM4.37X8	
12-4	S44436000	2	326クロスローラ	CROSS ROLLER, 326	
12-5	S44381001	1	オクリダイX	X-FEED BRACKET	
13	004400814	8	ササラコ4X8	SCREW, FLAT M4X8	
14	017761412	2	ボルト5.95X14	BOLT, SM5.95X14	
15	025060132	2	ヒラザガネシヨウ6	WASHER, PLAIN S 6	
86	018680822	2	アナボルト4.37X8	BOLT, SOCKET SM4.37X8	

From the library of: Diamond Needle Corp

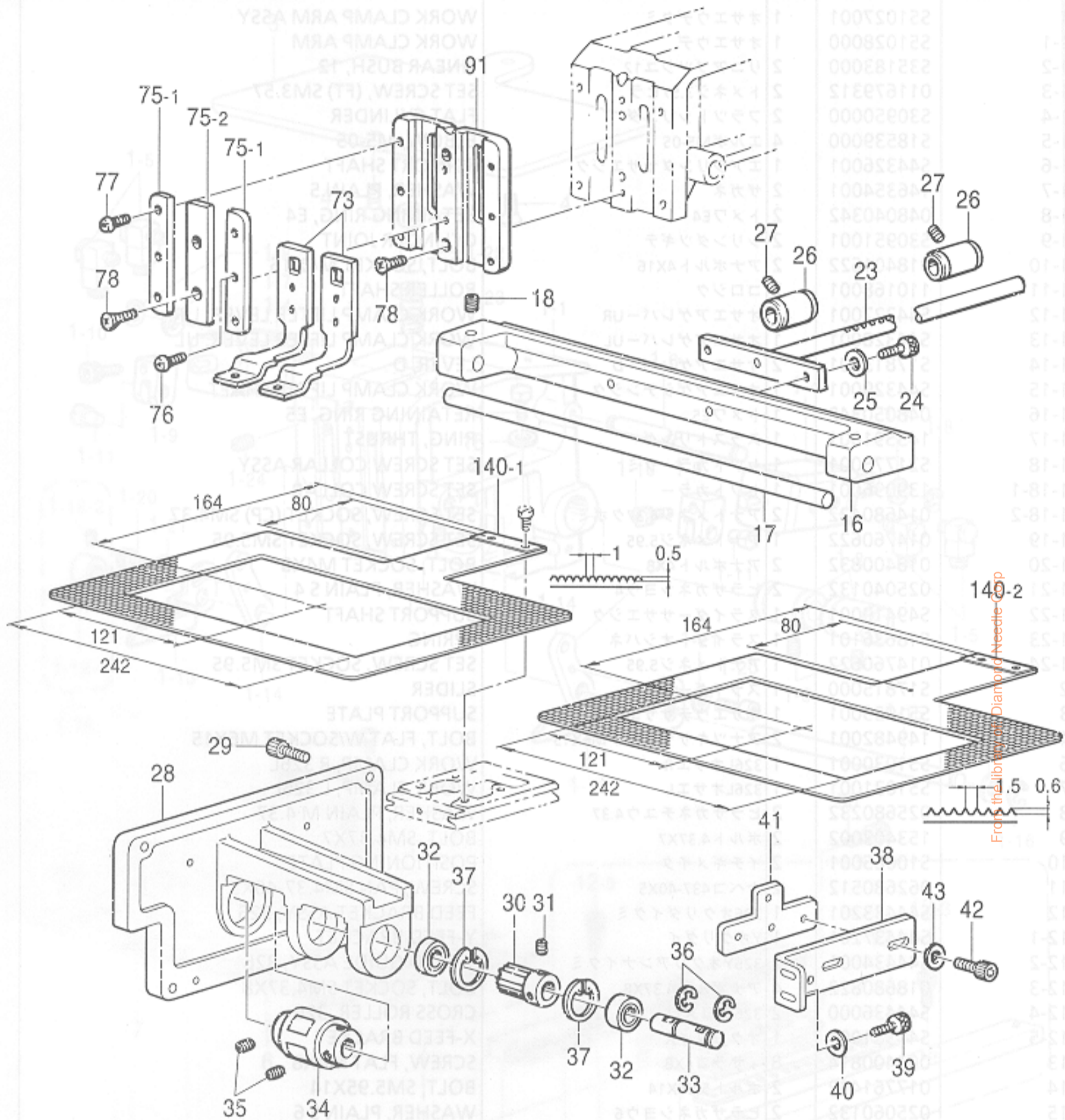

" オプション部品 / OPTION PARTS "

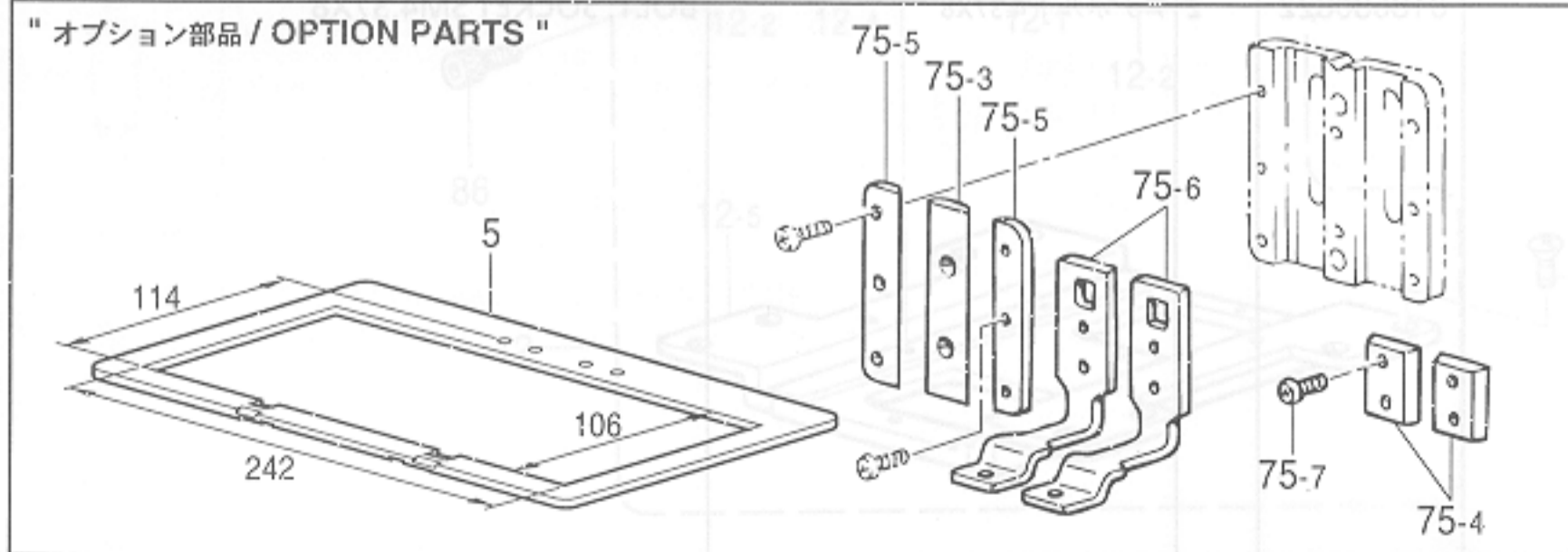

C2 . 送り関係 / Feed mechanism / Transportvorrichtung / Mécanisme de l'entraînement / Mecanismo de la alimentación

REF.NO.	CODE	Q'TY	ヒンメイ	NAME OF PARTS	RM
16	S51032000	1	326LXオクリジクササエ	X-FEED SHAFT HOLDER, 326L	
17	S51033001	1	326LXオクリジク	X-FEED SHAFT, 326L	
18	014760622	2	アナトメネジ5.95	SET SCREW, SOCKET SM5.95	
23	S51034001	1	Yクドウジク	Y-DRIVING SHAFT	
24	018501222	2	アナボルト5X12	BOLT, SOCKET M5X12	
25	025050232	2	ヒラザガネチユウ5	WASHER, PLAIN M 5	
26	S47112000	2	リニアブツシユ16	LINEAR BUSH, 16	
27	014680422	2	アナトメネジ4.37クボミ	SET SCREW, SOCKET (CP) SM4.37	
28	S51035001	1	YクドウPモータブラケット	PULSE MOTOR BRACKET, Y-FEED	
29	018016122	4	アナボルト6X16	BOLT, SOCKET M6X16	
30	S44443001	1	クドウギヤ	DRIVING GEAR	
31	014760622	2	アナトメネジ5.95	SET SCREW, SOCKET SM5.95	
32	S17868001	2	ミニチュアタマジクウケ	BALL BEARING, MINATURE	
33	S23445001	1	Yクドウギヤジク	Y-DRIVING GEAR SHAFT	
34	S23446000	1	カツフリング	COUPLING	
35	014760622	4	アナトメネジ5.95	SET SCREW, SOCKET SM5.95	
36	048080342	2	トメワE8	RETAINING RING, E8	
37	048220242	2	トメワアナヨウC22	RETAINING RING, INTERNAL C22	
38	S51036001	1	Yゲンテンブラケット	Y-HOME POSITION BRACKET	
39	018401022	2	アナボルト4X10	BOLT, SOCKET M4X10	
40	025040232	2	ヒラザガネチユウ4	WASHER, PLAIN M 4	
41	S44669001	1	Yセンサートリツケイタ	Y-SENSOR SETTING PLATE	
42	018400822	2	アナボルト4X8	BOLT, SOCKET M4X8	
43	025040232	2	ヒラザガネチユウ4	WASHER, PLAIN M 4	
73	S44447001	2	オサエアシSE	WORK CLAMP, SE	
75-1	S42787001	2	オサエアシオサエイタA	WORK CLAMP GUIDE BRACKET, A	
75-2	S42884001	1	オサエアシオサエイタB	WORK CLAMP GUIDE BRACKET, B	
76	062670712	2	ナベコ357-40X7	SCREW, PAN SM3.57-40X7	
77	062671212	4	ナベコ357-40X12	SCREW, PAN SM3.57-40X12	
78	107038003	4	サラネジ3.57	SCREW, FLAT SM3.57	
91	S44455001	1	オサエアシウケイタ	WORK CLAMP GUIDE PLATE	
	S44624000	1	X-TIMING BELT, B 311L	X-TIMING BELT, B 311L	
140-1	S51037001	1	<中厚物用> オクリイタ326LA t=1.2	<For Medium-weight materials> FEED PLATE, A 326L t=1.2	
140-2	S51038001	1	<厚物用> オクリイタ326LB t=1.2	<For Heavy-weight materials> FEED PLATE, B 326L t=1.2	
			" オプション部品 "	" OPTION PARTS "	
5	S51042001	1	326LオサエUN	WORK CLAMP, UN 326L	
75-3	S42798001	1	オサエアシオサエイタ	WORK CLAMP GUIDE BRACKET	
75-4	S44451001	2	オサエチヨウセツイタ	ADJUSTING PLATE	
75-5	S42800001	2	オサエスキマチヨウセツイタ	ADJUSTING PLATE	
75-6	S44453001	2	オサエアシSE-OP	PRESSER FOOT, SE-OP	
75-7	062670512	4	ナベコ357-40X5	SCREW, PAN SM3.57-40X5	
			RETAINING RING, INTERNAL C22	RETAINING RING, INTERNAL C22	
			BOLT, SOCKET M5X12	BOLT, SOCKET M5X12	
			WASHER, PLAIN M 5	WASHER, PLAIN M 5	
			BOLT, SOCKET M5X12	BOLT, SOCKET M5X12	

From the library of: Diamond Needle Corp

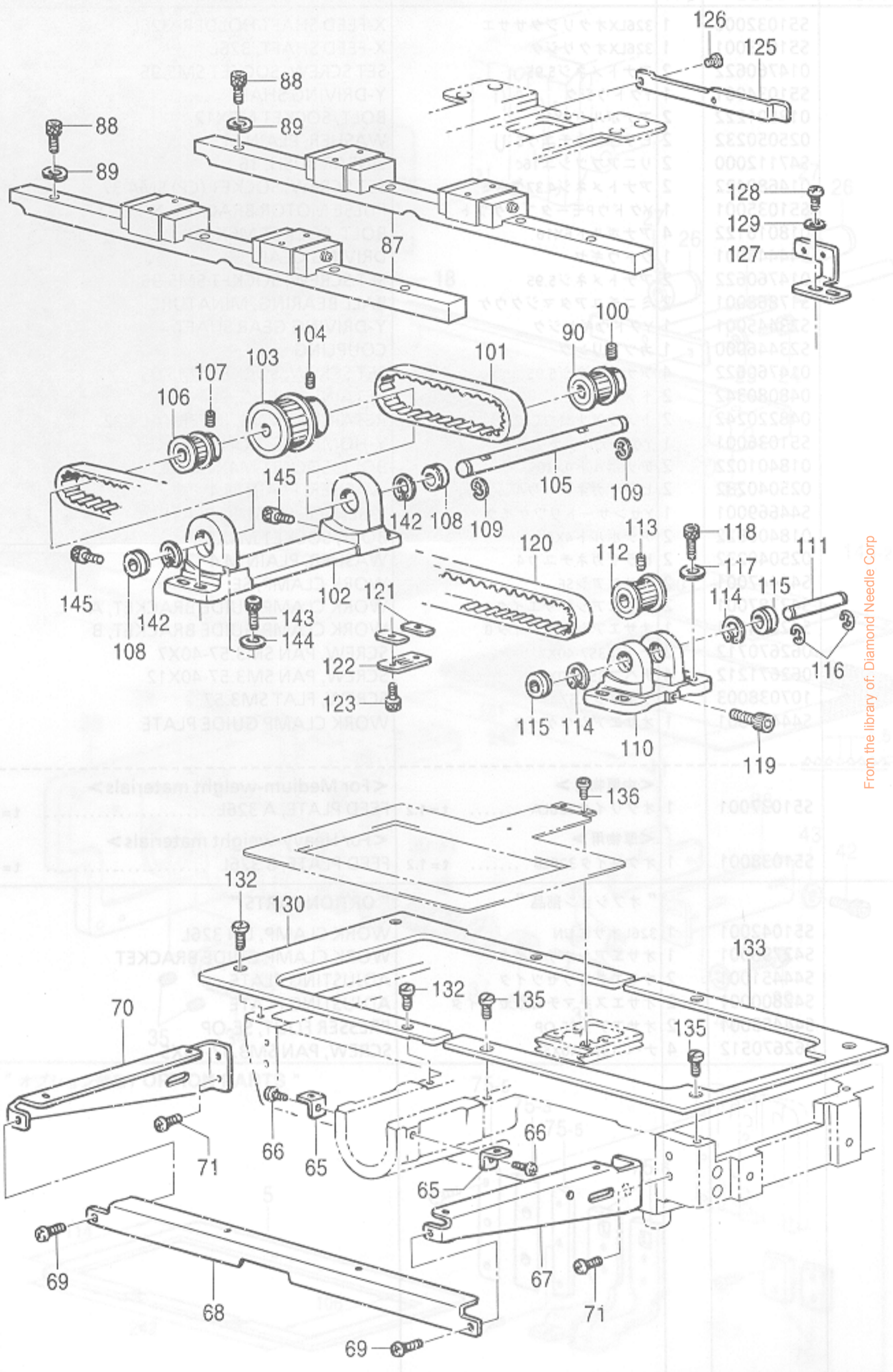

From the library of: Diamond Needle Corp

C3. 送り関係 / Feed mechanism / Transportvorrichtung / Mécanisme de l'entraînement / Mecanismo de la alimentación

REF.NO.	CODE	Q'TY	ヒンメイ	NAME OF PARTS	RM
65	S10091101	2	ハリイタホジヨイタササエ	AUXILIARY PLATE SUPPORT	
66	062680812	2	ナベコ437-40X8	SCREW, PAN SM4.37-40X8	
67	S44445001	1	ホジヨイタササエR	SUPPORT PLATE GUIDE, R	
68	S44757001	1	ホジヨイタササエM	SUPPORT PLATE GUIDE, M	
69	062680812	2	ナベコ437-40X8	SCREW, PAN SM4.37-40X8	
70	S44446001	1	ホジヨイタササエL	SUPPORT PLATE GUIDE, L	
71	062761012	4	ナベコ595-28X10	SCREW, PAN SM5.95-28X10	
87	S51039000	2	リニアガイド326L	LINEAR GUIDE, 326L	
88	018401636	11	アナボルト4X16	BOLT, SOCKET M4X16	
89	028040246	11	バネザガネ2-4	WASHER, SPRING 2-4	
90	S44382001	1	Xタイミングプーリア326	X-TIMING PULLEY, A 326	
100	014770622	2	アナトメネジ6.35クボミ	SET SCREW, SOCKET (CP) SM6.35	
101	S44456000	1	XタイミングベルトA326	X-TIMING BELT, A 326	
102	S44457000	1	Xプーリダイル	X-PULLEY BRACKET, L	
103	S44458001	1	XタイミングプーリB326	X-TIMING PULLEY, B 326	
104	014770622	2	アナトメネジ6.35クボミ	SET SCREW, SOCKET (CP) SM6.35	
105	S44459001	1	Xタイミングプーリジク	X-TIMING PULLEY SHAFT	
106	S17885101	1	タイミングプーリア	TIMING PULLEY, A	
107	014770622	2	アナトメネジ6.35クボミ	SET SCREW, SOCKET (CP) SM6.35	
108	530138001	2	マイクロベアリング8	MICRO BEARING, 8	
109	048060342	2	トメワE6	RETAINING RING, E6	
110	S17886100	1	XプーリダイR	X-PULLEY BRACKET, R	
111	S17887001	1	XプーリジクR	X-PULLEY SHAFT, R	
112	S17888001	1	タイミングプーリB	TIMING PULLEY, B	
113	014710522	2	アナトメネジ4.76クボミ	SET SCREW, SOCKET (CP) SM4.76	
114	048160242	2	トメワアナヨウC16	RETAINING RING, INTERNAL C16	
115	530138001	2	マイクロベアリング8	MICRO BEARING, 8	
116	048060342	2	トメワE6	RETAINING RING, E6	
117	025050232	4	ヒラザガネチユウ5	WASHER, PLAIN M 5	
118	018501622	4	アナボルト5X16	BOLT, SOCKET M5X16	
119	018501622	1	アナボルト5X16	BOLT, SOCKET M5X16	
120	S44624000	1	XタイミングベルトB311	X-TIMING BELT, B 311L	
121	S10078001	2	Tベルトスパーサ	SPACER, TIMING BELT	
122	S17890001	1	ベルトホルダ	BELT HOLDER	
123	018680822	2	アナボルト4.37X8	BOLT, SOCKET SM4.37X8	
125	S42795101	1	Xゲンテンドグ	HOME POSITION DOG, X	
126	S44924C01	2	シメネジM3X5.5	SCREW, M3X5.5	
127	S42796001	1	Xセンサートリツケイタ	X-SENSOR SETTING PLATE	
128	062400812	2	ナベコ4X8	SCREW, PAN M4X8	
129	025040232	2	ヒラザガネチユウ4	WASHER, PLAIN M 4	
130	S51040001	1	XYオクリダイカバーL	XY-FEED BRACKET COVER, L	
132	106629002	4	シメネジ4.37	SCREW, SM4.37	
133	S51041001	1	XYオクリダイカバーR	XY-FEED BRACKET COVER, R	
135	106629002	4	シメネジ4.37	SCREW, SM4.37	
136	S10352101	2	オクリイタシメネジ	SCREW, W/SOCKET SM4.37	
142	048160242	2	トメワアナヨウC16	RETAINING RING, INTERNAL C16	
143	018501622	4	アナボルト5X16	BOLT, SOCKET M5X16	
144	025050232	4	ヒラザガネチユウ5	WASHER, PLAIN M 5	
145	018501422	2	アナボルト5X14	BOLT, SOCKET M5X14	

From the library of: Diamond Needle Corp

C4. 送り関係 (オプション部品) / Feed mechanism (Option parts)
 / Transportvorrichtung (Sonderzubeh r) / M canisme de l«entra nement (Pi ces en option)
 / Mecanismo de la alimentaci n (Piezas opcionales)

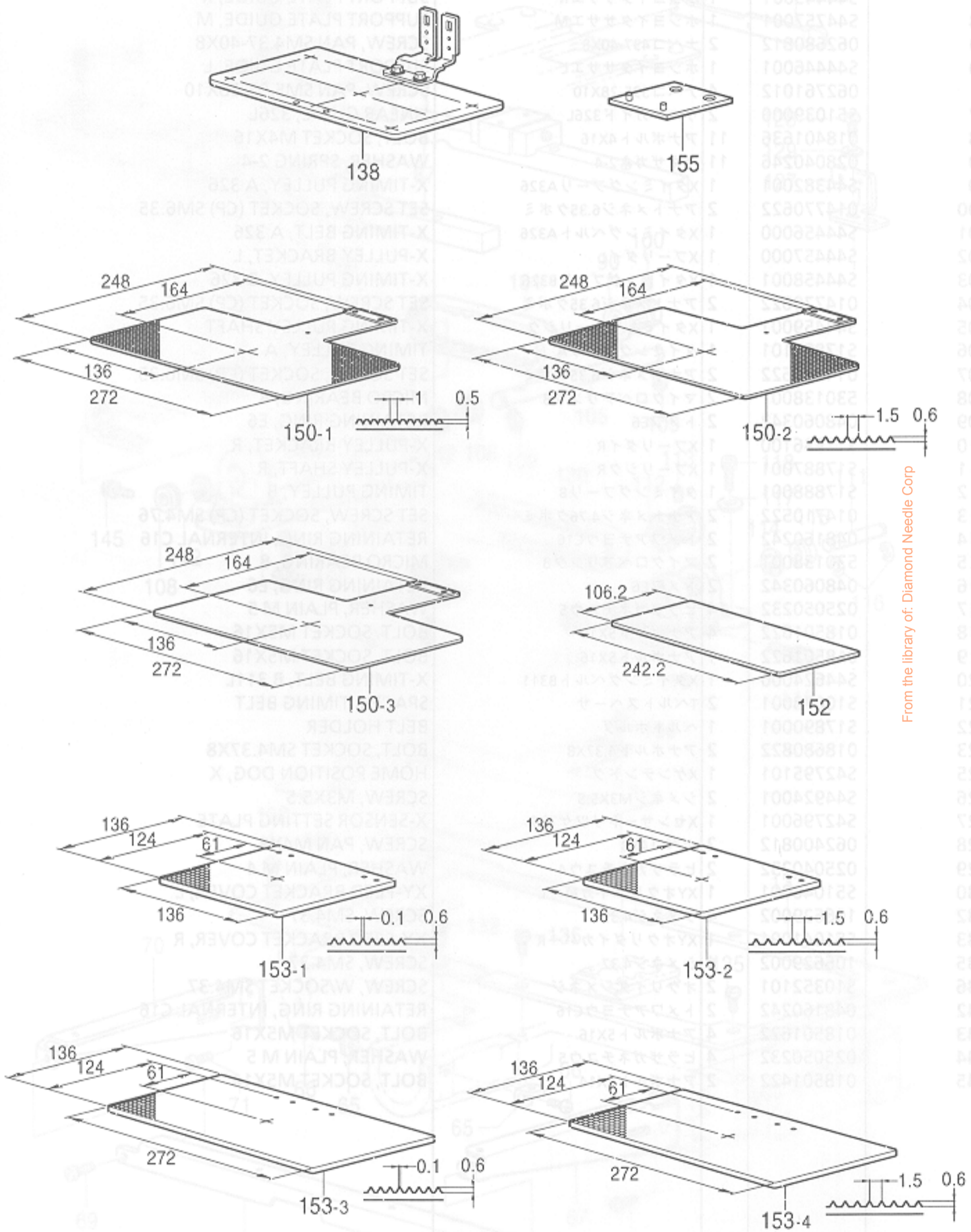

From the library of: Diamond Needle Corp

C4. 送り関係 (オプション部品) / Feed mechanism (Option parts)
 / Transportvorrichtung (Sonderzubehör) / Mécanisme de l'entraînement (Pièces en option)
 / Mecanismo de la alimentación (Piezas opcionales)

REF.NO.	CODE	Q'TY	ヒンメイ	NAME OF PARTS	RM
138	S51043001	1	<ゲージ部品> ゲンテンキジユンイタクミ	<Gauge parts> H-POSITION STANDARD PLATE ASSY	※
150-1	S51045001	1	<送り板用アタッチメント> オクリイタ326LAブランク t=1.2	<Attchment for feed plate> FEED PLATE BLANK, A 326L t=1.2	
150-2	S51046001	1	オクリイタ326LBブランク t=1.2	FEED PLATE BLANK, B 326L t=1.2	
150-3	S51047001	1	オクリイタ326LCブランク t=1.2	FEED PLATE BLANK, C 326L t=1.2	
152	S48555000	1	オクリイタインナープレート	INNER PLATE, FED PLATE	
153-1	S51051001	1	<押エブランク材用> オサエブランクLA3.2SE . t=3.2	<For work clamp blank> WORK CLAMP BLANK, SE A-3.2-L t=3.2	
153-1	S51053001	1	オサエブランクLA4.0SE . t=4.0	WORK CLAMP BLANK, SE A-4.0-L t=4.0	
153-1	S51055001	1	オサエブランクLA5.0SE . t=5.0	WORK CLAMP BLANK, SE A-5.0-L t=5.0	
153-1	S51057001	1	オサエブランクLA6.0SE . t=6.0	WORK CLAMP BLANK, SE A-6.0-L t=6.0	
153-2	S51052001	1	オサエブランクLB3.2SE .. t=3.2	WORK CLAMP BLANK, SE B-3.2-L t=3.2	
153-2	S51054001	1	オサエブランクLB4.0SE .. t=4.0	WORK CLAMP BLANK, SE B-4.0-L t=4.0	
153-2	S51056001	1	オサエブランクLB5.0SE .. t=5.0	WORK CLAMP BLANK, SE B-5.0-L t=5.0	
153-2	S51058001	1	オサエブランクLB6.0SE . t=6.0	WORK CLAMP BLANK, SE B-6.0-L t=6.0	
153-3	S51059001	1	オサエブランクLA3.2UN . t=3.2	WORK CLAMP BLANK, A-3.2 UN-L t=3.2	
153-3	S51061001	1	オサエブランクLA4.0UN . t=4.0	WORK CLAMP BLANK, A-4.0 UN-L t=4.0	
153-3	S51063001	1	オサエブランクLA5.0UN . t=5.0	WORK CLAMP BLANK, A-5.0 UN-L t=5.0	
153-3	S51065001	1	オサエブランクLA6.0UN . t=6.0	WORK CLAMP BLANK, A-6.0 UN-L t=6.0	
153-4	S51060001	1	オサエブランクLB3.2UN . t=3.2	WORK CLAMP BLANK, B-3.2 UN-L t=3.2	
153-4	S51062001	1	オサエブランクLB4.0UN . t=4.0	WORK CLAMP BLANK, B-4.0 UN-L t=4.0	
153-4	S51064001	1	オサエブランクLB5.0UN . t=5.0	WORK CLAMP BLANK, B-5.0 UN-L t=5.0	
153-4	S51066001	1	オサエブランクLB6.0UN . t=6.0	WORK CLAMP BLANK, B-6.0 UN-L t=6.0	
155	S14841001	1	<OT送り板用アタッチメント> OTオクリイタダイクミ	<Attachment for one-touch feed plate> OT-FEED PLATE BRACKET ASSY	

151-V26-202

- ☆ RM欄に※が付いている部品は、精密な組立て調整がして有りますので絶対に分解しないで下さい。
- ☆ Parts which have an asterisk (※) in the RM colum are parts which have been assembled and adijusted to high precisions. These parts should never be disassembled.
- ☆ Die in der Kolonne RM mit einem Asteriskus (※) bezeichneten Teile sind mit hoher präzision zusammengebaut und eigestellt worden. Aus diesem Grunde dürfen diese Teile niemals zerlegt werden.
- ☆ Les pièces désignées par un astérisque (※) dans la colonne RM sont des pièces qui ont été assemblées et réglées avec une grande précision. Il ne faut en aucun cas déposer ces pièces.
- ☆ Las partes que tienen un asterisco (※) en la columna RM son las partes que han sido armadas y ajustadas a alta precisión. Estas partes nunca deberán ser desarmadas.

C5 . 送り関係 (オプション部品) / Feed mechanism (Option parts)
 / Transportvorrichtung (Sonderzubehör) / Mécanisme de l'entraînement (Pièces en option)
 / Mecanismo de la alimentación (Piezas opcionales)

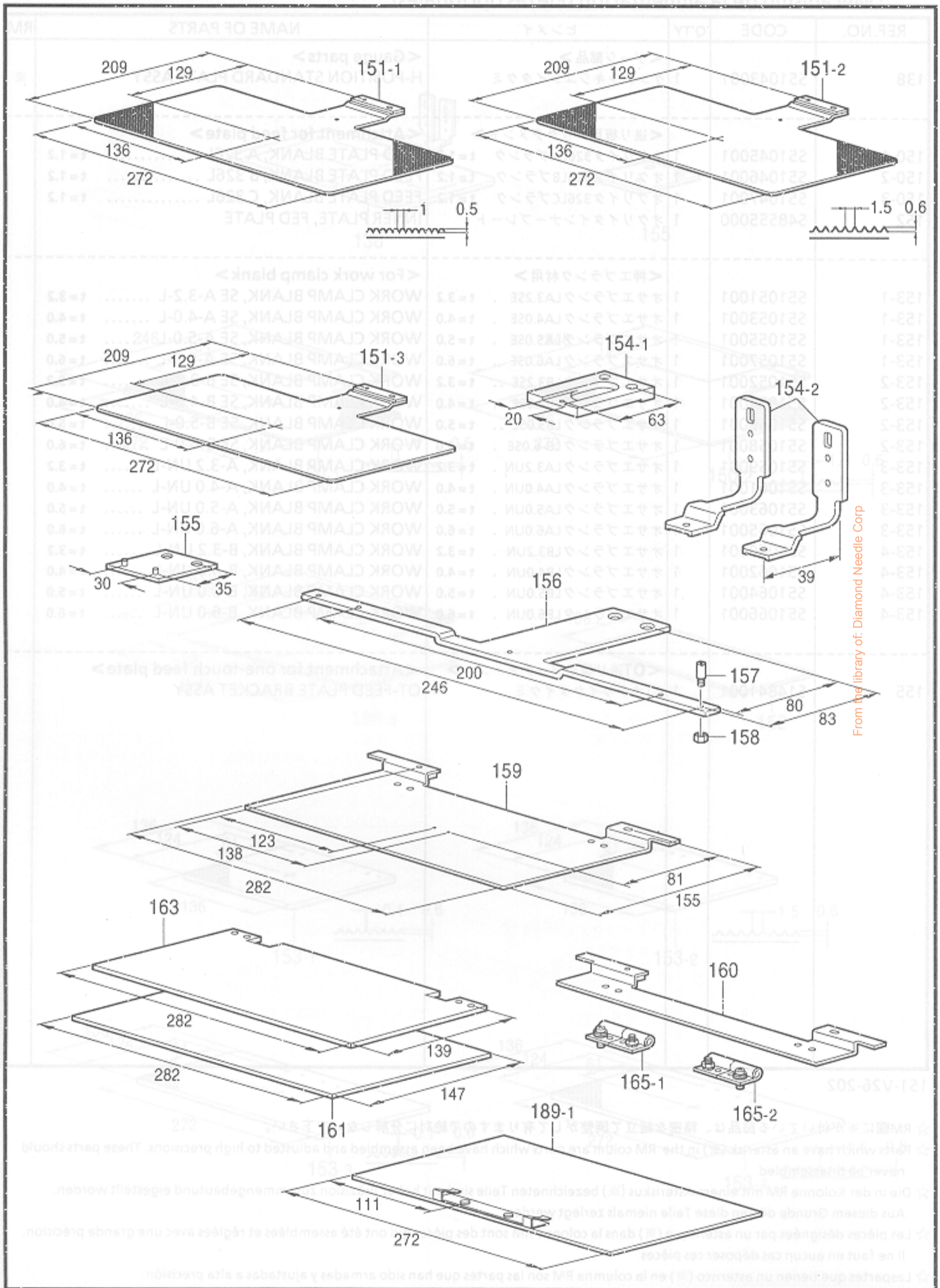

From the library of: Diamond Needle Corp

C5. 送り関係 (オプション部品) / Feed mechanism (Option parts)
 / Transportvorrichtung (Sonderzubehör) / Mécanisme de l'entraînement (Pièces en option)
 / Mecanismo de la alimentación (Piezas opcionales)

REF.NO.	CODE	Q'TY	ヒンメイ	NAME OF PARTS	RM
151-1	S51048001	1	<OT送り板 blanks材> OTオクリイタLA blanks t=1.2	<The blank for one-touch feed plate> OT-FEED PLATE BLANK, A 326L t=1.2	
151-2	S51049001	1	OTオクリイタLB blanks t=1.2	OT-FEED PLATE BLANK, B 326L t=1.2	
151-3	S51050001	1	OTオクリイタLC blanks t=1.2	OT-FEED PLATE BLANK, C 326L t=1.2	
155	S14841001	1	<OT送り板用アタッチメント> OTオクリイタダイクミ	<Attachment for one-touch fed plate> OT-FEED PLATE BRACKET ASSY	
154-1	S51804001	1	" BAS-326A, 326LA用 " <押工, 送り板用アタッチメント> オクリイタトリツケダイ	" For BAS-326A & BAS-326LA " <Attachment for work clamp & feed plate> FEED PLATE SETTING BRACKET	
154-2	S44413001	2	オサエアシSE-Z26	WORK CLAMP, SE-Z26	
189-1	S51067001	1	<ワンタッチ押工板組用> 326LOTオサエイタクミ05 t=0.5	<For Cassette clamp assy> OT-WORK CLAMP PLATE ASSY, 326L .. t=0.5	
189-1	S51069001	1	326LOTオサエイタクミ10 t=1.0	OT-WORK CLAMP PLATE ASSY, 326L .. t=1.0	
189-1	S51071001	1	326LOTオサエイタクミ20 t=2.0	OT-WORK CLAMP PLATE ASSY, 326L .. t=2.0	
156	S44411001	1	<押工板用アタッチメント> カセットシジイタ	<Attachment for cassette clamp> CASSETTE HOLDER PLATE	
157	S13007001	2	カセットシジピン	PIN, CASSETTE HOLDER	
158	021660306	2	3シユナツト318-40	NUT, 3 SM3.18-40	
159	S14392201	1	カセットイタD-A180	CASSETTE PLATE, D-A180	
160	S14388101	1	カセットイタD-B180	CASSETTE PLATE, D-B180	
161	S14386000	1	カセットシタイタA180 . t=1.0	CASSETTE LOWER PLATE, A-180 t=1.0	
161	S14387000	1	カセットシタイタB180 . t=2.0	CASSETTE LOWER PLATE, B-180 t=2.0	
163	S14389000	1	カセットイタU-A180 ... t=1.0	CASSETTE PLATE, U-A180 t=1.0	
163	S14390000	1	カセットイタU-B180 ... t=2.0	CASSETTE PLATE, U-B180 t=2.0	
165-1	152632001	1	チヨウバンクミミギ	HINGE ASSY, R	
165-2	152633001	1	チヨウバンクミヒダリ	HINGE ASSY, L	
64-2	S42844001	1	オサエアシ	PRESSER FOOT, B	
64-3	S42845001	1	オサエアシ	PRESSER FOOT, C	
64-4	S42846001	1	オサエアシ	PRESSER FOOT, D	
64-5	S42847001	1	オサエアシ	PRESSER FOOT, E	
64-6	S51072001	1	オサエアシ	PRESSER FOOT, G	
64-7	S57237001	1	オサエアシ	PRESSER FOOT, F	
64-8	S42848001	1	オサエアシ	PRESSER FOOT, J	
64-9	S42849001	1	<横置ワイパー用> オサエアシXY	<For Horizontal wiper> PRESSER FOOT, XY	
70	S42850001	1	オサエアシ	PRESSER BAR, SIDE	

From the library of: Diamond Needle Corp

D. 押工上げ関係 / Work clamp lifter mechanism / Stoffhalterheber / Releveur de pinceur
 / Mecanismo del levantador del prensor

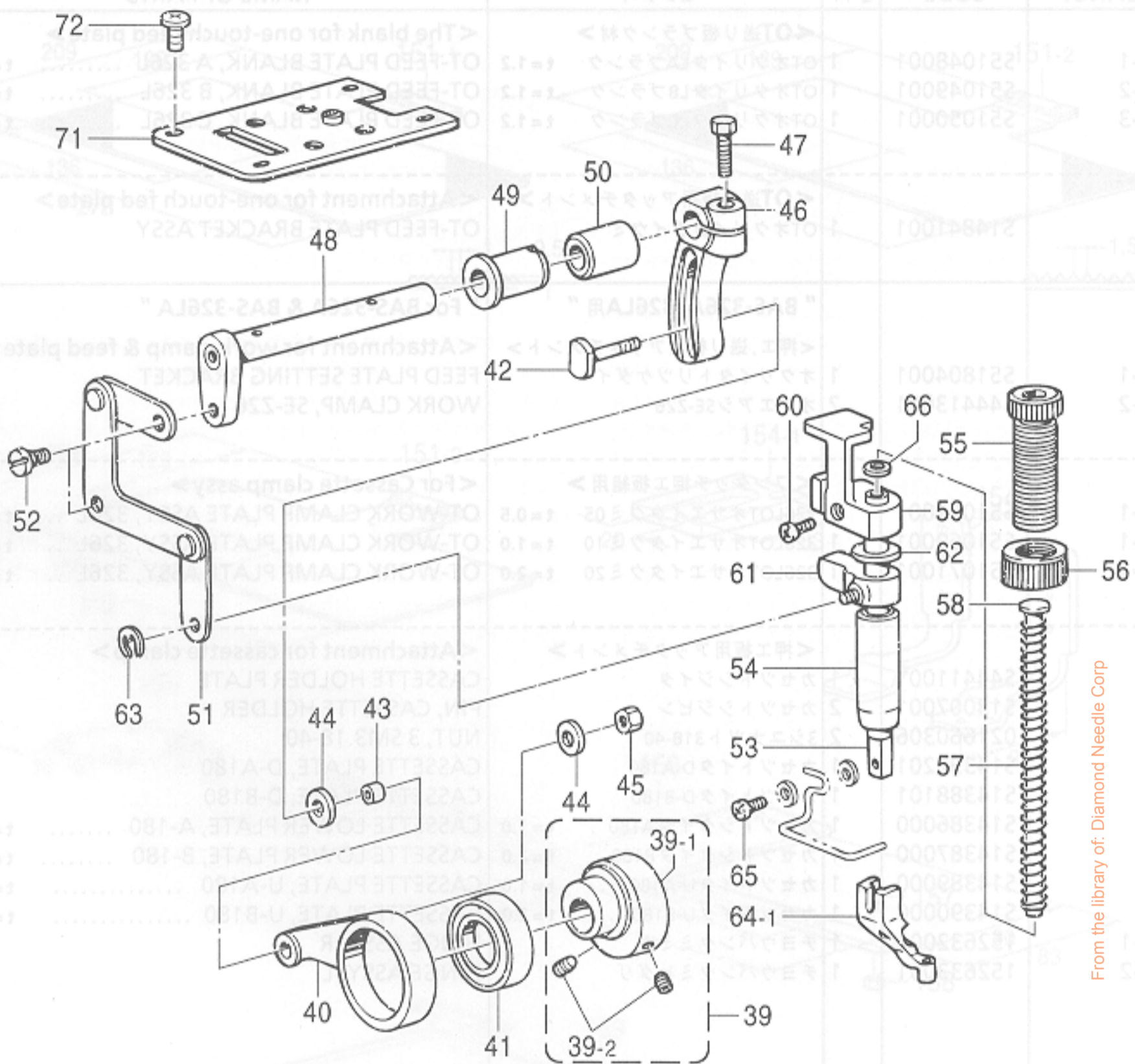

From the library of: Diamond Needle Corp

" オプション部品 / OPTION PARTS "

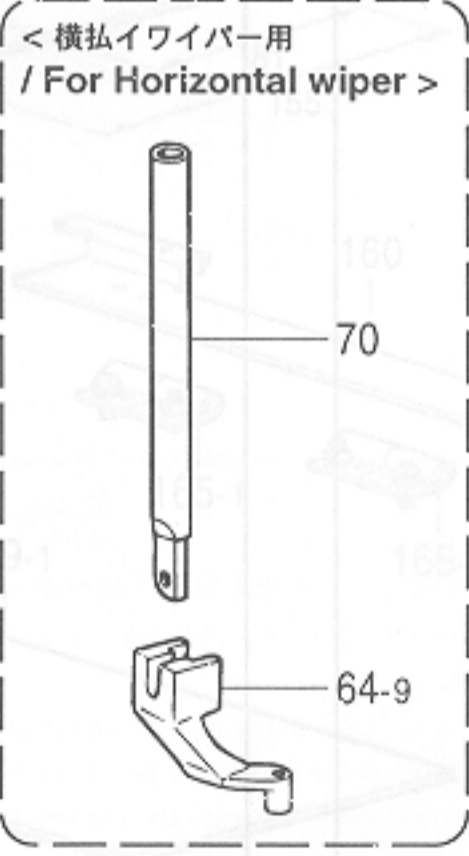
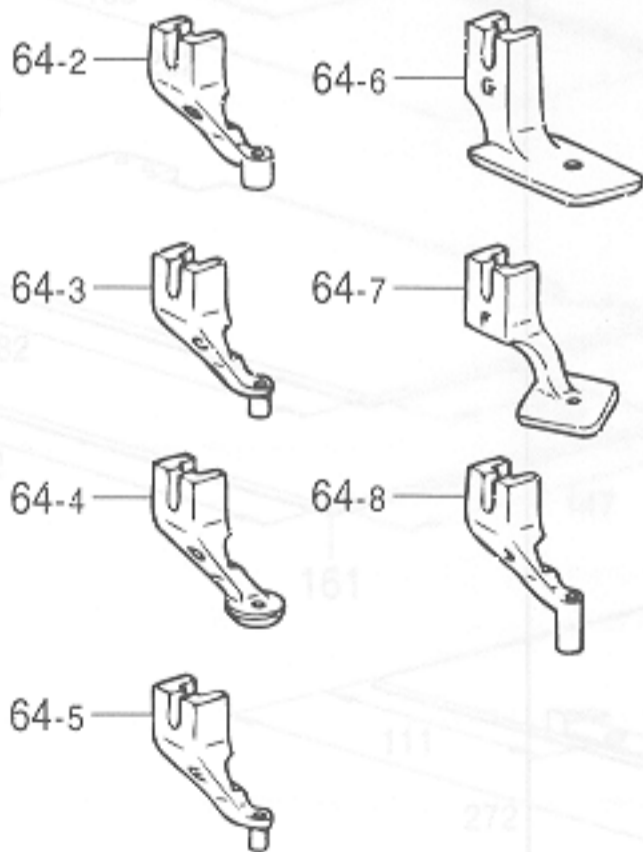

D. 押工上げ関係 / Work clamp lifter mechanism / Stoffhalterheber / Releveur de pinceur
/ Mecanismo del levantador del prensor

REF.NO.	CODE	Q'TY	ヒンメイ	NAME OF PARTS	RM
39	S42836001	1	カンケツオサエカムクミ	STEPPING WORK CLAMP CAM ASSY	
39-1	S42837001	1	カンケツオサエカム	STEPPING WORK CLAMP CAM	
39-2	014760622	2	アナトメネジ5.95	SET SCREW, SOCKET SM5.95	
40	S43693000	1	カンケツオサエレンカン	STEPPING WORK CLAMP CON. ROD	
41	623033000	1	タマジクウケ6805VV	BALL BEARING, 6805VV	
42	150460001	1	U-UDオクリレバージク	U-UD FEED LIFTER LEVER SHAFT	
43	150461001	1	オクリコロ	FEED ROLLER	
44	107453001	2	ザガネ	WASHER	
45	021750102	1	1シユナツト556-32	NUT, 1 SM5.56-32	
46	S17871101	1	カンケツオサエウデR	STEPPING WORK CLAMP ARM, R	
47	017751412	1	ボルト5.56X14	BOLT, SM5.56X14	
48	S42839101	1	カンケツオサエウデF	STEPPING WORK CLAMP ARM, F	
49	148196000	1	ウワメスサドウウデメタルL	BUSH, L SPREADER SHAFT	
50	148197000	1	ウワメスサドウウデメタルR	BUSH, R SPREADER SHAFT	
51	S42840101	1	カンケツリンククミ	STEPPING LINK ASSY	
52	155167002	2	ダンネジ5.56	SHOULDER SCREW, SM5.56	
53	111466101	1	オサエボウ	PRESSER BAR	
54	145472001	1	オサエボウメタル	BUSH, PRESSER BAR	
55	S31012001	1	オサエチヨウセツネジ	ADJUSTING SCREW, PRESSER	
56	S31013001	1	チヨウセツネジツマミナツト	ADJUSTING NUT, PRESSER	
57	S10111101	1	オサエバネ	SPRING, COMPRESSION	
58	S10112001	1	オサエバネアンナイ	SPRING GUIDE	
59	S10113201	1	オサエボウダキ	GUIDE BRACKET, P-BAR	
60	062681212	1	ナベコ437-40X12	SCREW, PAN SM4.37-40X12	
61	S10371001	1	オサエボウリフター	PRESSER BAR LIFTER	
62	S10372100	1	オサエボウダキクツシヨン	CUSHION	
63	048040342	1	トメワE4	RETAINING RING, E4	
64-1	S42843001	1	オサエアシA	PRESSER FOOT, A	
65	S13399001	1	シメネジ3.57X12	SCREW, SM3.57X12	
66	S03677001	1	ザガネ	WASHER	
71	S37973201	1	ソレノイドトリツケイタ	SETTING PLATE, SOLENOID	
72	060680712	4	バインド437-40X7	SCREW, BIND SM4.37-40X7	
64-2	S42844001	1	オサエアシB	PRESSER FOOT, B	
64-3	S42845001	1	オサエアシC	PRESSER FOOT, C	
64-4	S42846001	1	オサエアシD	PRESSER FOOT, D	
64-5	S42847001	1	オサエアシE	PRESSER FOOT, E	
64-6	158592001	1	オサエアシG	PRESSER FOOT, G	
64-7	157237001	1	オサエアシF	PRESSER FOOT, F	
64-8	S42848001	1	オサエアシJ	PRESSET FOOT, J	
64-9	S42849001	1	オサエアシXY	PRESSER FOOT, XY	
70	S42880001	1	オサエボウヨコ	PRESSER BAR, SIDE	
14-2	S42837001	1	シャッターベース	SHUTTER BASE ASSY, WP	
14-2-1	S40838001	1	シャッターベース	SHUTTER BASE	
14-2-2	S40839001	1	スライダ	SLIDER	
14-2-3	062660412	2	ナベコ3.8-40X4	SCREW, PAN SM3.8-40X4	
14-2-4	152683001	2	オオカ	SETTING CLAW, S-RACE BODY	
14-2-5	152684101	2	オオカ	SPRING, COMPRESSION	
14-2-6	402887001	2	ザガネ	WASHER, 3.2	
14-2-7	062660712	2	ナベコ3.18-40X7	SCREW, PAN SM3.18-40X7	
19-2	S40840001	1	ドライバー	DRIVER, WP	

From the library of: Diamond Needle Corp

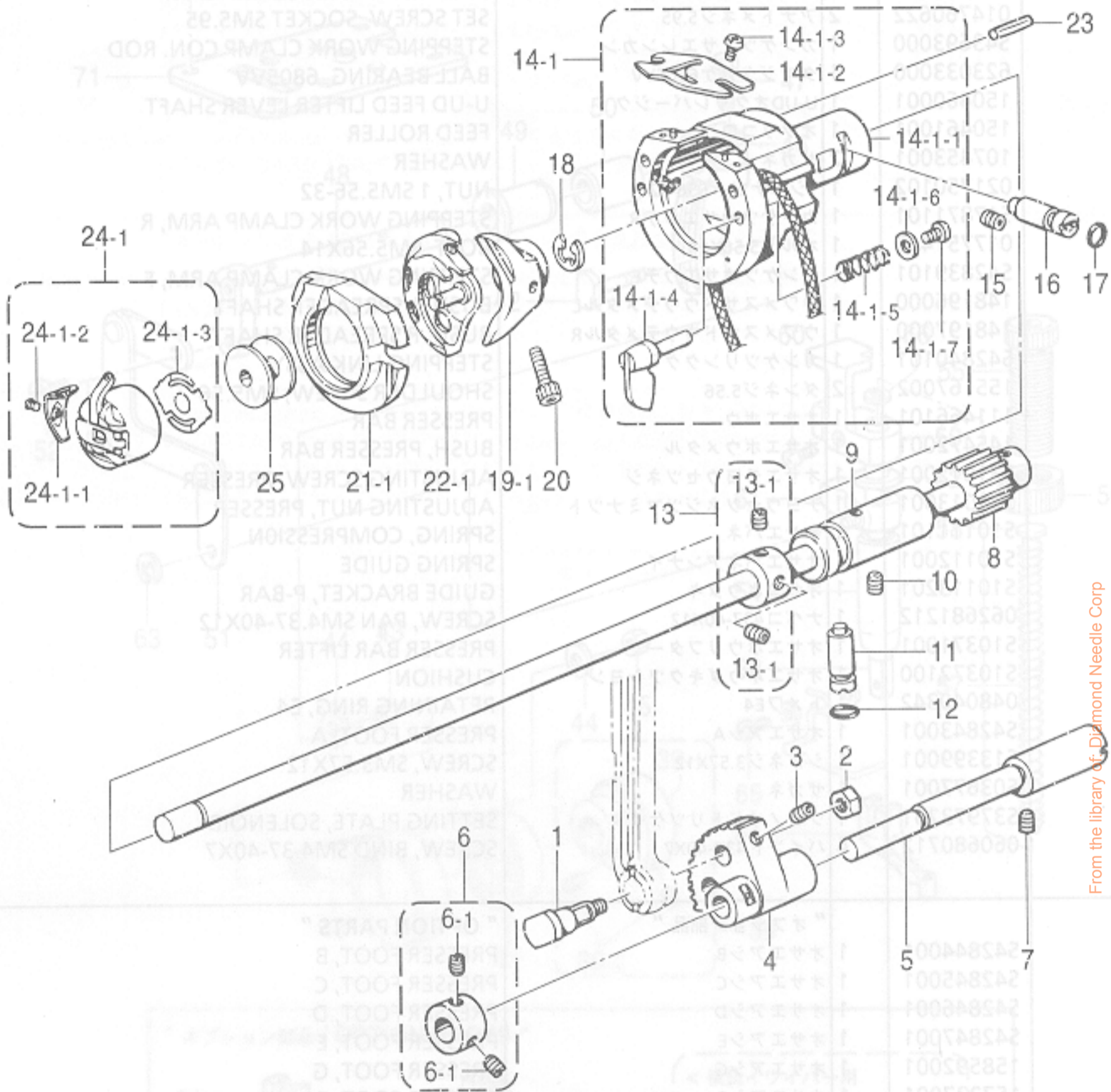

From the library of: Diamond Needle Corp

" オプション部品 / OPTION PARTS "
 < WPステッチ装置用 / For Wide perfect stitch device >

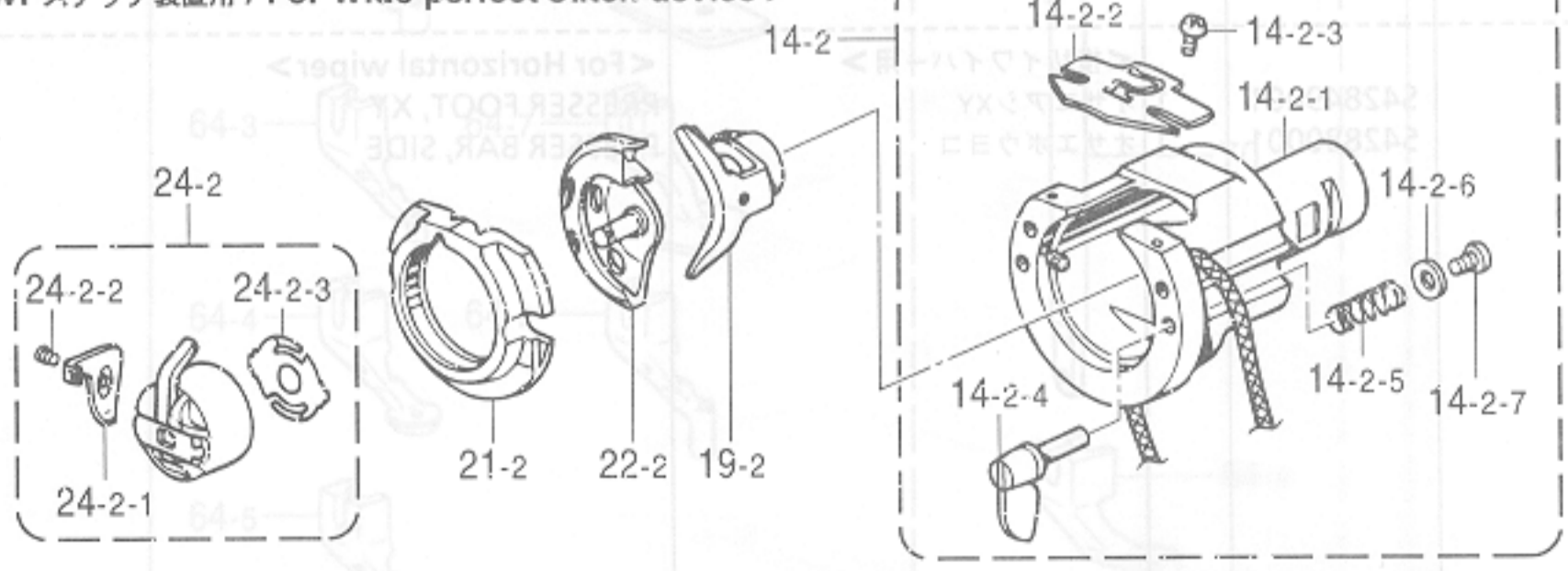

E. 下軸関係 / Lower shaft mechanism / Untere Welle / Mécanisme de l'arbre inférieur
/ Mecanismo del eje inferior

REF.NO.	CODE	Q'TY	ヒンメイ	NAME OF PARTS	RM
1	141786001	1	クランクロッドダンネジ	SHOULDER SCREW, CRANK ROD	
2	100090004	1	ナット7.14	NUT, SM7.14	
3	014680622	1	アナトメネジ4.37クボミ	SET SCREW, SOCKET (CP) SM4.37	
4	152245001	1	ヨウドウギヤ	ROCKER GEAR	
5	S37978151	1	ヨウドウギヤジク	ROCKER GEAR SHAFT	
6	181995001	1	セットカラークミ	SET SCREW COLLAR ASSY	
6-1	101706001	2	トメネジ6.35	SET SCREW, SM6.35	
7	014760622	2	アナトメネジ5.95	SET SCREW, SOCKET SM5.95	
8	S37979101	1	シタジククミ	LOWER SHAFT ASSY	
9	S37981051	1	シタジクメタル	LOWER SHAFT BUSH	
10	014760622	1	アナトメネジ5.95	SET SCREW, SOCKET SM5.95	
11	152678101	1	カマチヨウセツジク	ADJUSTING STUD, SHUTTLE HOOK	
12	081003670	1	リングPW3	O RING, PW3	
13	S03704002	1	セットカラークミ	SET SCREW COLLAR ASSY	
13-1	014770622	2	アナトメネジ6.35クボミ	SET SCREW, SOCKET (CP) SM6.35	
14-1	S42818101	1	NVオオカマタイクミ	SHUTTLE RACE ASSY, NV	
14-1-1	S40886001	1	NVオオカマタイ	SHUTTLE RACE BASE, NV	
14-1-2	S02429101	1	カマイトアンナイ	THREAD GUIDE, S-RACE BODY	
14-1-3	062660412	2	ナベコ318-40X4	SCREW, PAN SM3.18-40X4	
14-1-4	152683001	2	オオカマトリツケツメ	SETTING CLAW, S-RACE BODY	
14-1-5	152684101	2	オオカマトリツケバネ	SPRING, COMPRESSION	
14-1-6	402887001	2	ザガネ3.2	WASHER, 3.2	
14-1-7	062660712	2	ナベコ318-40X7	SCREW, PAN SM3.18-40X7	
15	014760622	1	アナトメネジ5.95	SET SCREW, SOCKET SM5.95	
16	152678101	1	カマチヨウセツジク	ADJUSTING STUD, SHUTTLE HOOK	
17	081003670	1	リングPW3	O RING, PW3	
18	048080342	1	トメワE8	RETAINING RING, E8	
19-1	152681201	1	ドライバー	DRIVER	
20	018501422	1	アナボルト5X14	BOLT, SOCKET M5X14	
23	120438001	1	ミゾツキピン	PIN, DOWEL	
21-1	152682101	1	<中厚物用> オオカマA	<For Medium-weight materials> SHUTTLE RACE BODY, A	
22-1	S15662992	1	ナカカマLAハコクミ	SHUTTLE HOOK, LA W/BOX	
21-1	152686101	1	<厚物用> オオカマB	<For Heavy-weight materials> SHUTTLE HOOK BASE, B	
22-1	S15663991	1	ナカカマLBハコクミ	SHUTTLE HOOK, LB W/BOX	
24-1	S15902401	1	<中厚物, 厚物用> ボビンケースクミLA	<For Medium & Heavy-weight materials> BOBBIN CASE ASSY, LA	
24-1-1	S16074101	1	ケースチヨウシバネA	TENSION SPRING, A	
24-1-2	S16492101	1	ボビンケースバネネジ	SCREW, BOBBIN CASE SPRING	
24-1-3	S15667001	1	クウテンボウシバネ	SPRING, ANTI-SPIN	
25	S15665001	1	ボビンLA	BOBBIN, LA	
14-2	S40837001	1	" オプション部品 "	" OPTION PARTS "	
14-2-1	S40838001	1	<WPステッチ装置用> Z11オオカマタイWPクミ	<For Wide perfect stitch device> SHUTTLE RACE BASE ASSY, WP	
14-2-2	S40839001	1	オオカマタイWP	SHUTTLE RACE BASE, WP	
14-2-3	062660412	2	カマイトアンナイWP	THREAD GUIDE, WP S-RACE BODY	
14-2-4	062660412	2	ナベコ318-40X4	SCREW, PAN SM3.18-40X4	
14-2-5	152683001	2	オオカマトリツケツメ	SETTING CLAW, S-RACE BODY	
14-2-6	152684101	2	オオカマトリツケバネ	SPRING, COMPRESSION	
14-2-7	402887001	2	ザガネ3.2	WASHER, 3.2	
19-2	062660712	2	ナベコ318-40X7	SCREW, PAN SM3.18-40X7	
19-2	S40840001	1	ドライバーWP	DRIVER, WP	

From the library of: Diamond Needle Corp

E. 下軸関係 / Lower shaft mechanism / Untere Welle / M canisme de l'arbre inf rieur / Mecanismo del eje inferior

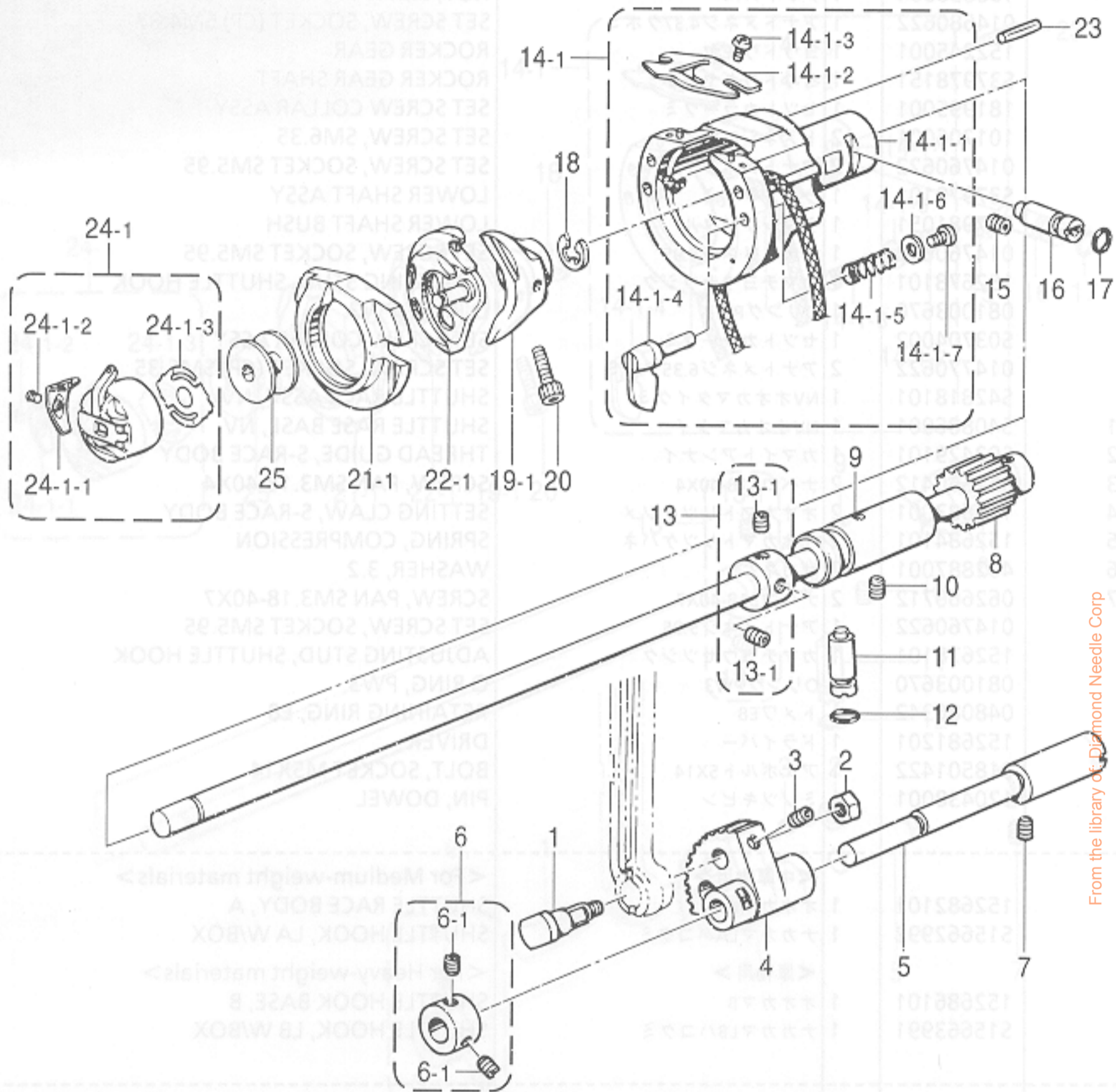

" オプション部品 / OPTION PARTS "
 < WPステッチ装置用 / For Wide perfect stitch device >

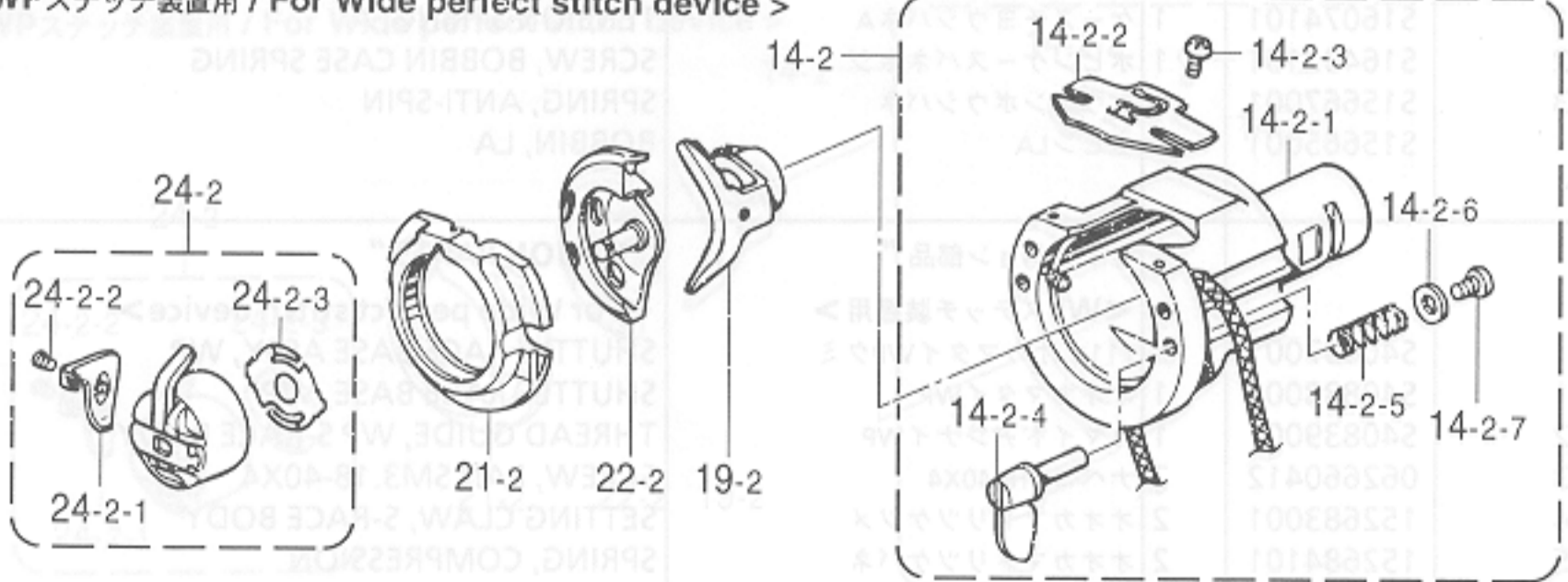

E. 下軸関係 / Lower shaft mechanism / Untere Welle / Mécanisme de l'arbre inférieur / Mecanismo del eje inferior

REF.NO.	CODE	Q'TY	品名	NAME OF PARTS	RM
	S2948001	1	" オプション部品 "	" OPTION PARTS "	
21-2	S40841101	1	オオカマWP	SHUTTLE RACE BODY, WP	
22-2	S40842991	1	ナカカマWPハコクミ	SHUTTLE HOOK, WP W/BOX	
24-2	S40843001	1	ボビンケースクミWP	BOBBIN CASE ASSY, WP	
24-2-1	S40845001	1	ケースチヨウシバネWP	TENSION SPRING, WP	
24-2-2	S16492101	1	ボビンケースバネネジ	SCREW, BOBBIN CASE SPRING	
24-2-3	S15667001	1	クウテンボウシバネ	SPRING, ANTI-SPIN	
	S025680232	1	ワッシャー	WASHER	
	S15903401	1	< 極厚物用 > ボビンケースクミLB	< For Extra heavy-weight materials > BOBBIN CASE ASSY, LB	
24-1-1	S16075101	1	ケースチヨウシバネB	TENSION SPRING, B	
24-1-2	S16492101	1	ボビンケースバネネジ	SCREW, BOBBIN CASE SPRING	
24-1-3	S15667001	1	クウテンボウシバネ	SPRING, ANTI-SPIN	
25	S15666001	1	ボビンLB	BOBBIN, LB	
6	S060670512	2	ネジ	SCREW, BIND SM3.57-40X5	
7	S37984000	1	オイルチューブ	OIL TUBE, L=290	
8	S18093100	1	ワック	WICK, 4X4 L=100	
9	S153562801	1	ワック	FLAT WICK, L=160	
10	S151927001	1	フェルト	FELT, CLUTCH	
11	S104567001	2	ワックサポート	WICK-SUPPORT	
13	S042827000	1	オイルチューブ	OIL TUBE, L=60	
14	S046405000	1	オイルチューブ	OIL TUBE, L=60	
15	S18093100	1	ワック	WICK, 4X4 L=110	
16	S145547001	1	チューブホルダー	TUBE HOLDER	
17	S062670512	1	ネジ	SCREW, PAN SM3.57-40X5	
18	S37987001	1	フェルトサポート	FELT SUPPORT	
19	S37988000	1	フェルト	FELT	
20	S062630512	1	ネジ	SCREW, PAN SM3.57-40X5	
21	S09043000	1	フェルト	FELT	
22	S152948001	1	オイルウィンドウ	OIL WINDOW	
24	S37984000	1	オイルチューブ	OIL TUBE, L=250	
25	S043673000	1	オイルチューブ	OIL TUBE, L=290	
26	S112738000	1	ワック	WICK, L=400	
27	S107149001	1	フェルト	FELT	
28	S152969001	2	コードスワッチカネ	CODER SWATCH KANE	
29	S062670512	2	ネジ	SCREW, PAN SM3.57-40X5	
34	S228475000	3	ステンレスバンド	STAINLESS BAND, 1.9X80	
35	S09043000	2	フェルト	FELT	
36	S108892001	1	ワック	WICK, L=250	
37	S17901000	1	ワック	WICK, L=160	
38	S117150001	1	コードスワッチカネ	CODER SWATCH KANE	
39	S062670512	1	ネジ	SCREW, PAN SM3.57-40X5	
41	S13006001	1	フェルト	FELT	

From the library of: Diamond Needle Corp

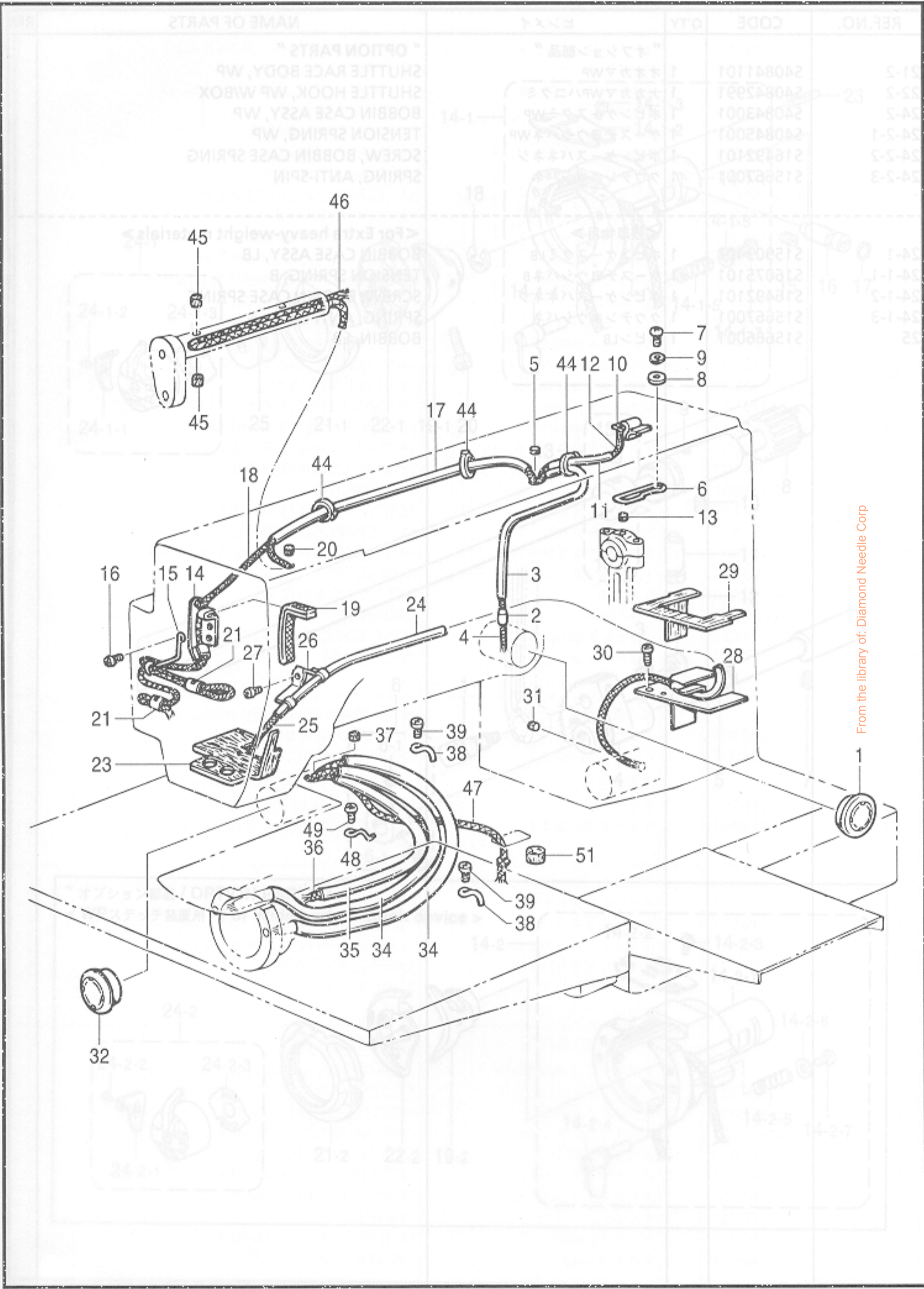

From the library of: Diamond Needle Corp

F. 給油潤滑関係 / Lubrication / Schmierung / Lubrification / Lubricación

/Mecanismo del enhebrado

observed no lebr omanism

REF.NO.	CODE	Q'TY	ヒンメイ	NAME OF PARTS	RM
1	152948001	1	オイルホツトマド	OIL WINDOW	
2	S07333001	1	オイルクチパイプS	OIL FEEDING PIPE, S	
3	S07456000	1	ビニールチューブ	OIL TUBE, L = 160	
4	148738000	1	クミヒモ 37-40X6	WICK, L = 335	
5	107149001	1	フェルト	FELT	
6	S37983001	1	ウワジクキユウユササエ	WICK SUPPORT	
7	062680612	1	ナベコ4.37-40X6	SCREW, PAN SM4.37-40X6	
8	025680232	1	ヒラザガネチユウ4.37	WASHER, PLAIN M 4.37	
9	028680242	1	バネザガネ2-4.37	WASHER, SPRING 2-4.37	
10	S10478000	1	ロツドキユウユフエルト	FELT	
11	S34986000	1	ビニルチューブ	OIL TUBE, L = 135	
12	153920001	1	クミヒモ4X4	WICK, 4X4 L = 300	
13	107149001	1	フェルト	FELT	
14	S21527001	1	テンピンキユウユササエ	WICK SUPPORT	
15	S10162201	1	ハリボウヒモササエ	WICK SUPPORT	
16	060670512	1	バインド357-40X5	SCREW, BIND SM3.57-40X5	
17	S37984000	1	ビニルチューブ	OIL TUBE, L = 290	
18	S18093100	1	クミヒモ4X4	WICK, 4X4 L = 1100	
19	153562001	1	ヒラクミヒモ	FLAT WICK, L = 160	
20	151927001	1	クラッチフェルト	FELT, CLUTCH	
21	104567001	2	クミヒモササエ	WICK SUPPORT	
23	S42827000	1	スリアゲフェルト	FELT	
24	S46405000	1	ビニルチューブ	OIL TUBE, L = 460	
25	S18093100	1	クミヒモ4X4	WICK, 4X4 L = 1100	
26	145547001	1	チューブホルダ	TUBE HOLDER	
27	062670512	1	ナベコ357-40X5	SCREW, PAN SM3.57-40X5	
28	S37987001	1	シタジクキユウユササエ	FELT SUPPORT	
29	S37988000	1	シタジクキユウユフエルト	FELT	
30	062680612	1	ナベコ4.37-40X6	SCREW, PAN SM4.37-40X6	
31	S09043000	1	フェルト	FELT	
32	152948001	1	オイルホツトマド	OIL WINDOW	
34	S37984000	2	ビニルチューブ	OIL TUBE, L = 290	
35	S43673000	1	ビニルチューブ	OIL TUBE, L = 240	
36	112738000	1	クミヒモ	WICK, L = 400	
37	107149001	1	フェルト	FELT	
38	152969001	2	コードササエカネ	CORD SUPPORT	
39	062670512	2	ナベコ357-40X5	SCREW, PAN SM3.57-40X5	
44	228475000	3	ケツソクバンド1.9X80	FASTENING BAND, 1.9X80	
45	S09043000	2	フェルト	FELT	
46	108802001	1	クミヒモ4X4	WICK, 4X4 L = 250	
47	S17901000	1	クミヒモ	WICK, 4X4 L = 460	
48	117150001	1	コードササエカネ	CORD SUPPORT	
49	062670512	1	ナベコ357-40X5	SCREW, PAN SM3.57-40X5	
51	113006001	1	フェルト	FELT	
27	152881001	1	エキレイトカケ	THREAD GUIDE, NEEDLE BAR BUSH	
28	014680612	1	アナトメネジ4.37クボミ	SET SCREW, SOCKET (CP) SM4.37	
29	152883000	1	フェルト8X15.5	FELT, 8X15.5	
30	152884001	1	エキレイトカケ	THREAD GUIDE, NEEDLE COOLER	
31	062670412	1	ナベコ357-40X4	SCREW, PAN SM3.57-40X4	
32	S12441001	1	チヨウシバネウエザガネ	WASHER	
25-2	S41222101	1	ハリボウイトアンナイB	THREAD GUIDE, NEEDLE BAR	
25-3	S02439001	1	ハリボウイトアンナイB	THREAD GUIDE, NEEDLE BAR	

From the library of: Diamond Needle Corp



G. 糸通シ関係 / Threading mechanism / Fadenführungsvorrichtung / Mechanisme de l'enfilage / Mecanismo del enhebrado

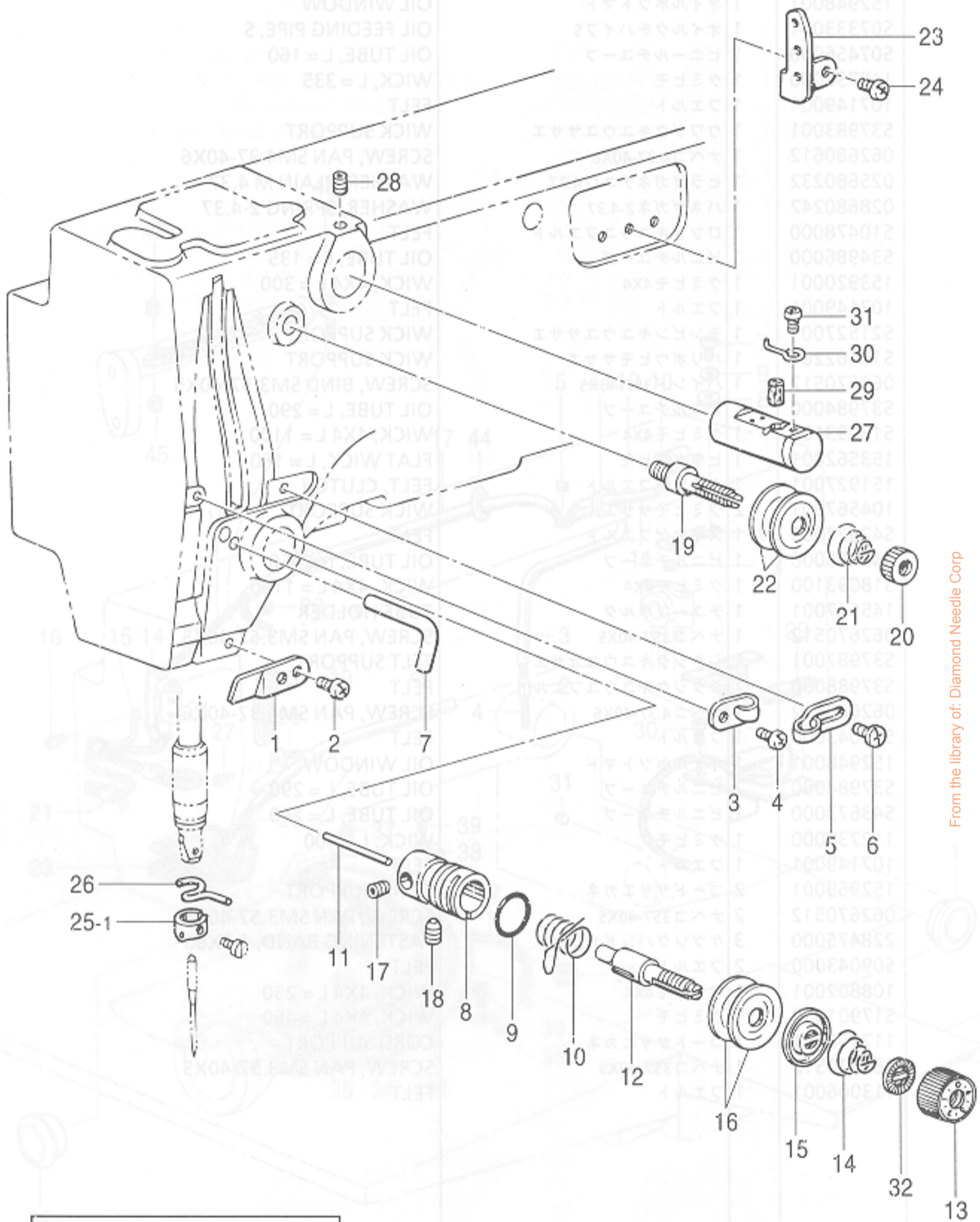

From the library of: Diamond Needle Corp

" オプション部品
/ OPTION PARTS "

25-2 25-3

G. 糸通シ関係 / Threading mechanism / Fadenführungs-vorrichtung / Mécanisme de l'enfilage / Mecanismo del enhebrado

REF.NO.	CODE	Q'TY	ヒンメイ	NAME OF PARTS	RM
1	152869001	1	アームイトミチ	THREAD GUIDE, ARM	
2	062710612	1	ナベコ476-32X6	SCREW, PAN SM4.76-32X6	
3	152870001	1	アームイトカケ	THREAD GUIDE, ARM	
4	062670612	1	ナベコ357-40X6	SCREW, PAN SM3.57-40X6	
5	113316001	1	アームイトアンナイ	THREAD GUIDE, ARM	
6	060670612	1	バインド357-40X6	SCREW, BIND SM3.57-40X6	
7	159224001	1	アームイトカケ	THREAD GUIDE, ARM	
8	152872001	1	イトチヨウシダイ	TENSION BRACKET (CP) SM3.57	
9	114294001	1	Oリング	O RING BOBBIN WINDER	
				SET SCREW, SOCKET (CP) SM4.37	
10	145519001	1	<中厚物用> イトトリバネ	<For Medium-weight materials> SPRING BOBBIN WINDER	
10	144588001	1	<厚物用> イトトリバネB	<For Heavy-weight materials> SPRING, B (CP) SM4.37-40X8	
11	S12699000	1	イトユルメピン	PIN	
12	100398001	1	イトチヨウシボウ	TENSION STUD	
13	S11182009	1	イトチヨウシナツトクミ	TENSION NUT ASSY	
14	104525001	1	<中厚物用> イトチヨウシバネ	<For Medium-weight materials> SPRING, TENSION	
14	107606001	1	<厚物用> イトチヨウシバネ	<For Heavy-weight materials> SPRING, TENSION	
15	159805001	1	イトチヨウシサラオサエ	DISC PRESSER, TENSION	
16	145446001	2	イトチヨウシサラ	DISC, TENSION	
17	100402004	1	トメネジ3.57	SET SCREW, SM3.57	
18	103950003	1	トメネジ5.95	SET SCREW, (CN) SM5.95	
19	115186001	1	シュイトチヨウシボウ	TENSION STUD, MAIN	
20	100136001	1	イトチヨウシナツト	NUT, TENSION	
21	115188001	1	シュイトチヨウシバネ	SPRING, TENSION	
22	145446001	2	イトチヨウシサラ	DISC, TENSION	
23	152889001	1	ミツメイトカケ	THREAD RETAINER	
24	062670612	2	ナベコ357-40X6	SCREW, PAN SM3.57-40X6	
25-1	S02438001	1	<中厚物, 厚物用> ハリボウイトアンナイA	<For Medium & Heavy -weight materials> THREAD GUIDE, A NEEDLE BAR	
26	152891101	1	ハリボウメタルDイトアンナイ	THREAD GUIDE, NEEDLE BAR BUSH	
27	152881001	1	エキレイタイクミ	NEEDLE COOLER ASSY	
28	014680622	1	アナトメネジ4.37クボミ	SET SCREW, SOCKET (CP) SM4.37	
29	152883000	1	フェルト8X15.5	FELT, 8X15.5	
30	152884001	1	エキレイイトカケ	THREAD GUIDE, NEEDLE COOLER	
31	062670412	1	ナベコ357-40X4	SCREW, PAN SM3.57-40X4	
32	S12441001	1	チヨウシバネウエザガネ	WASHER	
25-2	S41222101	1	" オプション部品 "	" OPTION PARTS "	
25-3	S02439001	1	ハリボウイトアンナイB	THREAD GUIDE, B NEEDLE BAR	

From the library of: Diamond Needle Corp

H. 糸巻関係 / Bobbin winder mechanism / Spuler / M canisme du bobineur / Mecanismo del devanador de la canilla

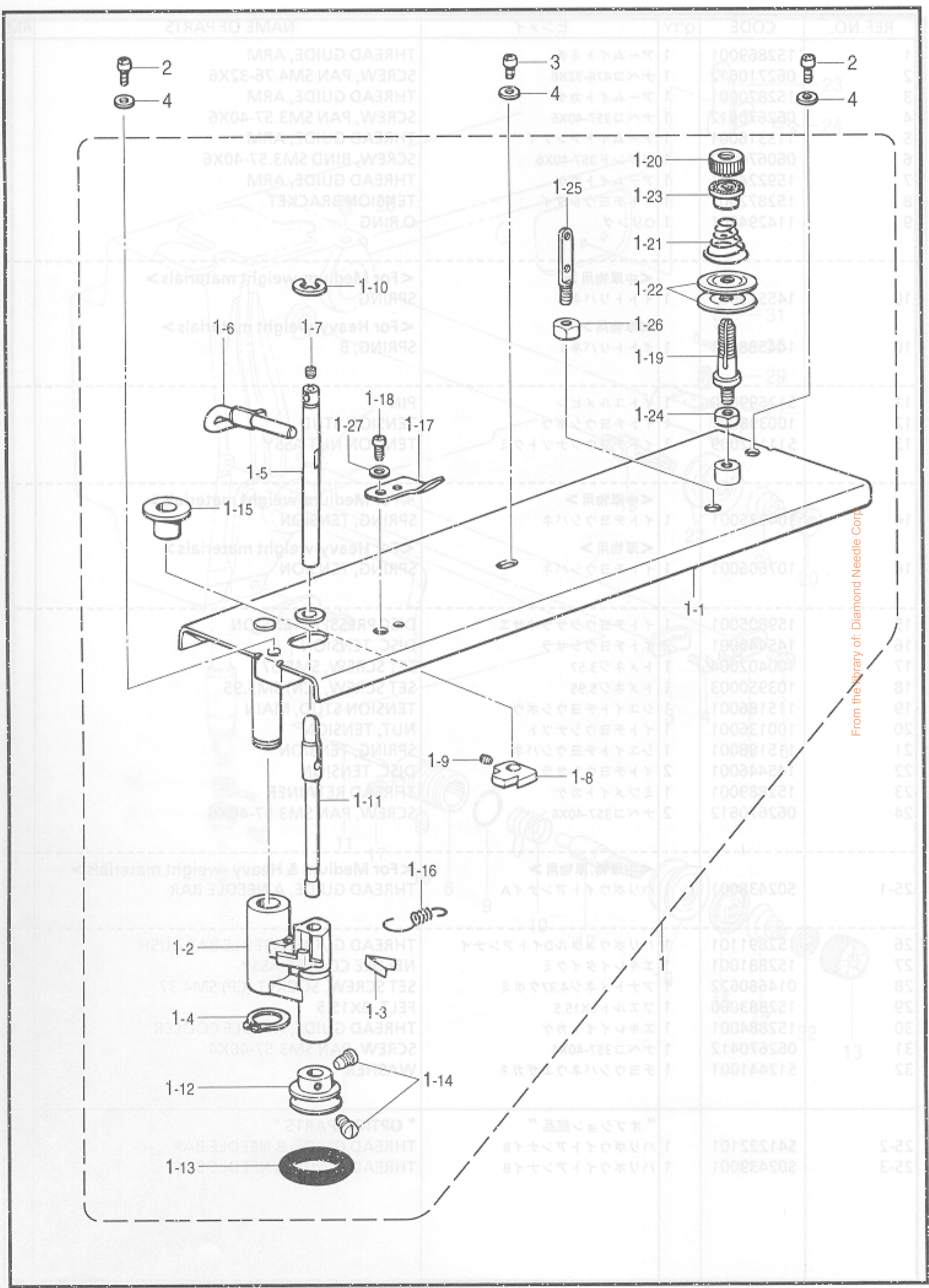

From the library of: Diamond Needle Corp.

H. 糸巻関係 / Bobbin winder mechanism / Spuler / Mécanisme du bobineur
/ Mecanismo del devanador de la canilla

REF.NO.	CODE	Q'TY	ヒンメイ	NAME OF PARTS	RM
1	S37990309	1	ウワフタクミ	TOP COVER ASSY	
1-1	S37991109	1	ウワフタ	TOP COVER	
1-2	S37992100	1	イトマキウデ	BOBBIN WINDER ARM	
1-3	S37993000	1	イタバネ	SPRING, PLATE	
1-4	048100142	1	トメワジクヨウC10	RETAINING RING, EXTERNAL C10	
1-5	S37994001	1	イトマキツメジク	STUD, BOBBIN WINDER CLAW	
1-6	S37995101	1	ボビンオサエ	BOBBIN PRESSER	
1-7	014679320	1	アナトメネジ3.57クボミ	SET SCREW, SOCKET (CP) SM3.57	
1-8	S37996001	1	イトマキツメ	CLAW, BOBBIN WINDER	
1-9	014680622	1	アナトメネジ4.37クボミ	SET SCREW, SOCKET (CP) SM4.37	
1-10	048050342	1	トメワE5	RETAINING RING, E5	
1-11	S37997001	1	イトマキジク	SHAFT, BOBBIN WINDER	
1-12	154528001	1	イトマキクルマ	WHEEL, BOBBIN WINDER	
1-13	120448001	1	ゴムワ	RUBBER RING	
1-14	120990001	2	アタマツキトメネジ4.37	SET SCREW, (CP) SM4.37-40X8	
1-15	S10174000	1	ホコリヨケイタ	DUST GUARD PLATE	
1-16	S37998001	1	イトマキウデバネ	SPRING	
1-17	152938001	1	メス	KNIFE	
1-18	062680512	1	ナベコ437-40X5	SCREW, PAN SM4.37-40X5	
1-19	159574101	1	イトチヨウシボウ	TENSION STUD	
1-20	100136001	1	イトチヨウシナツト	NUT, TENSION	
1-21	144110001	1	シタルーパイトチヨウシバネ	THREAD TENSION ADJUST SPRING	
1-22	145446001	2	イトチヨウシサラ	DISC, TENSION	
1-23	144105000	1	チヨウシバネウエザガネ	FLANGE WASHER, TENSION SPRING	
1-24	021680202	1	ナツト2シユ4.37	NUT, 2 SM4.37	
1-25	141590001	1	イトトオシボウ	THREADING BAR, U	
1-26	100022004	2	ナツト5.95	NUT, SM5.95	
1-27	025680232	1	ヒラザガネチユウ4.37	WASHER, PLAIN M 4.37	
2-5	062681212	2	ナベコ437-40X12	SCREW, PAN SM4.37-40X12	
3-6	062680812	1	ナベコ437-40X8	SCREW, PAN SM4.37-40X8	
4	025680232	3	ヒラザガネチユウ4.37	WASHER, PLAIN M 4.37	
23	S02354001	1	シヤクキチヤク	SHOULDER SCREW	
24	100022005	1	ナツト5.95	NUT, SM5.95	
25	S42886101	1	イトチヨウシボウ	THREAD TRIMMER ROD ASSY, S	
25-1	S42887101	1	イトチヨウシボウ	THREAD TRIMMER ROD	
25-2	S01492001	1	イトチヨウシボウ	JOINT ASSY	
25-3	S106588003	1	ナツト5.95	NUT, SM5.95	
26	S10333001	1	ナベコ4.76	SHOULDER SCREW, SM4.76	
27	S10333002	1	ナベコ4.76	WASHER	
28	S11011001	1	ナツト4.76	NUT, SM4.76	
29	S088010001	1	イトチヨウシボウ	LEVER, THREAD TRIMMER	
30	S10185001	1	イトチヨウシボウ	LEVER SHAFT	
31	S110367001	1	ナベコ4.76	WASHER, PLAIN M 4.76	
32	048060342	1	トメワE5	RETAINING RING	
33	014680622	1	アナトメネジ4.37クボミ	SET SCREW, SOCKET SM5.95	
34	S38011001	1	イトチヨウシボウ	SPRING, EXTENSION	
35	S158940001	1	バネカケ	SPRING HOOK	
36	S110233001	1	ダンネジ4.76	SHOULDER SCREW, SM4.76	
37	S110161004	1	ナツト4.76	NUT, SM4.76	
38	S153483001	1	ナベコ4.76	WASHER, PLAIN M 4.76	
39	025680232	1	ヒラザガネチユウ4.37	WASHER, PLAIN M 4.37	
40	S428862001	1	イトチヨウシボウ	CONNECTING ROD LEVER ASSY	
41	S10202101	1	イトチヨウシボウ	CONNECTING ROD LEVER SHAFT	
42	014680422	1	アナトメネジ4.37クボミ	SET SCREW, SOCKET (CP) SM4.37	
43	S44388001	1	イトチヨウシボウ	NEEDLE PLATE	
44	S10204101	1	イトチヨウシボウ	THREAD TRIMMER CONNECTING ROD	
45-1	S102051001	1	イトチヨウシボウ	MOVABLE KNIFE ASSY	
46	S10208001	1	イトチヨウシボウ	SPACER, MOVABLE KNIFE T = 0.4	
46	S10208002	1	イトチヨウシボウ	SPACER, MOVABLE KNIFE T = 0.5	

From the library of: Diamond Needle Corp

J. 糸切り関係 / Thread trimmer mechanism / Fadenabschneidevorrichtung

/ M canisme de coupe-fil / Mecanismo de la cortadura de hiros

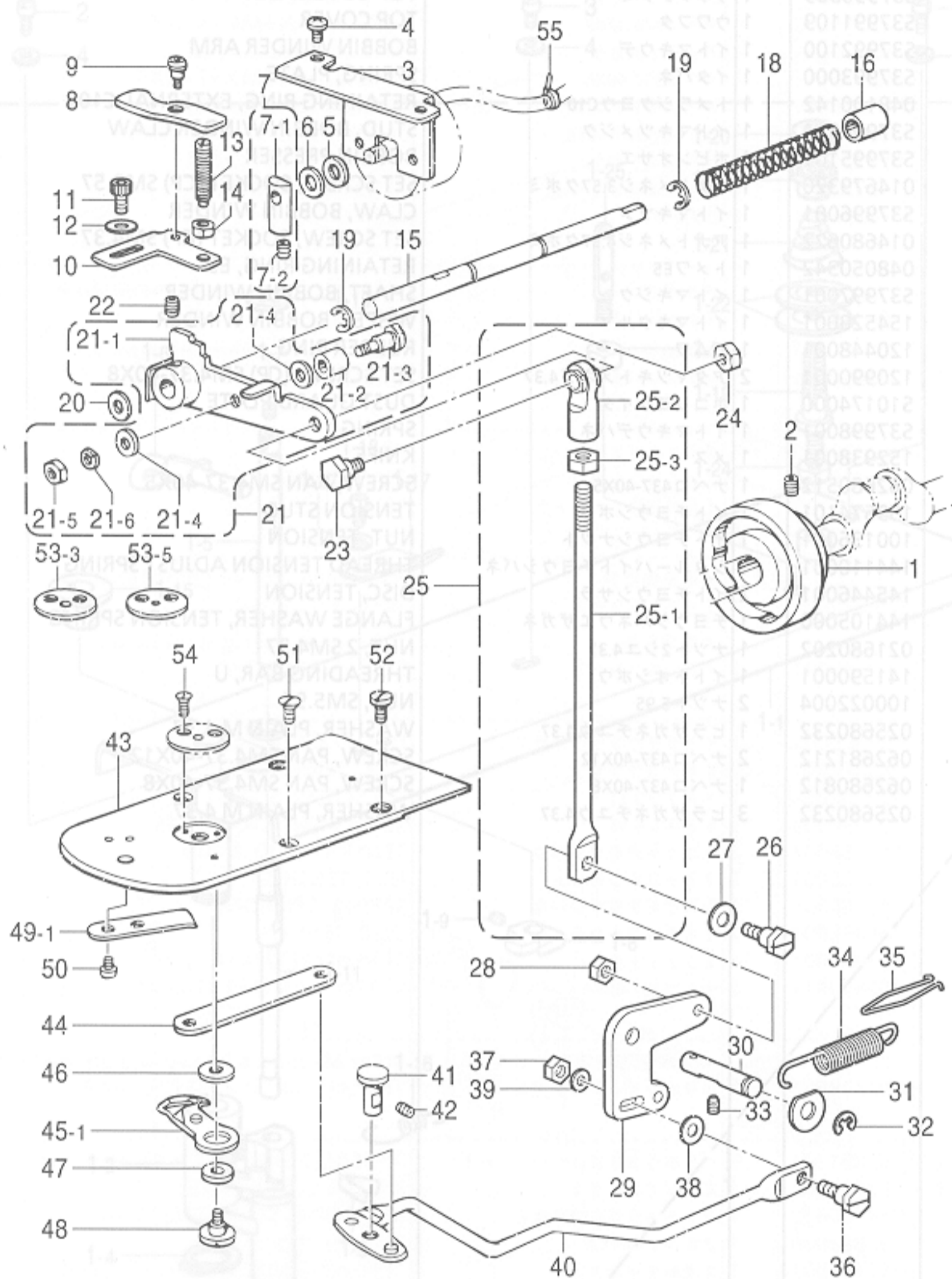

From the library of: Diamond Needle Corp

" オプション部品 / OPTION PARTS "

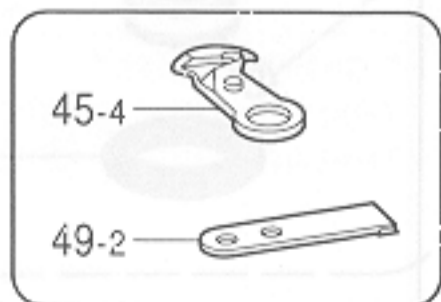

J. 糸切り関係 / Thread trimmer mechanism / Fadenabschneidevorrichtung
/ Mécanisme de coupe-fil / Mecanismo de la cortadura de hiros

REF.NO.	CODE	Q'TY	ヒンメイ	NAME OF PARTS	RM
1	S38001001	1	イトキリカム	CAM, THREAD TRIMMER	
2	014770622	2	アナトメネジ6.35クボミ	SET SCREW, SOCKET (CP) SM6.35	
3	S38002101	1	ソレノイドトリツケイタ	SETTING PLATE, SOLENOID	
4	060680712	2	バインド437-40X7	SCREW, BIND SM4.37-40X7	
5	154599000	1	ソレノイドクツシヨン	CUSHION, SOLENOID	
6	S02652001	1	ザガネ	WASHER	
7	S23836001	1	ソレノイドレバークミ	SOLENOID LEVER ASSY	
7-1	S02654001	1	ソレノイドレバー	SOLENOID LEVER	
7-2	014680622	1	アナトメネジ4.37クボミ	SET SCREW, SOCKET (CP) SM4.37	
8	S38003001	1	クドウレバーオシレバー	PUSHING LEVER, DRIVING LEVER	
9	145478101	1	ダンネジ4.76	SHOULDER SCREW, SOCKET SM4.76	
10	S38004002	1	クドウレバーストツバ <記号2>	DRIVING LEVER STOPPER, H = 0.3 <marked :2>	
10	S38004003	1	クドウレバーストツバ <記号3>	DRIVING LEVER STOPPER, H = 0.6 <marked :3>	
10	S38004004	1	クドウレバーストツバ <記号4>	DRIVING LEVER STOPPER, H = 0.45 <marked :4>	
11	018681022	2	アナボルト4.37X10	BOLT, SOCKET SM4.37X10	
12	148847001	2	ザガネ	WASHER, PLAIN 4.76Mark	
13	159905001	1	トメヌイチヨウセツネジ	ADJUSTTING SCREW	
14	106147002	1	ナツト7.94	NUT, SM7.94	
15	S38005001	1	クドウレバーアンナイジク	DRIVING LEVER SHAFT	
16	231071001	1	メタル8X15	BUSH, 8X15	
18	S10189001	1	クドウジクモドシバネ	SPRING, COMPRESSION	
19	048070342	2	トメワE7	RETAINING RING, E7	
20	154596000	1	イトキリカムレバークツシヨン	CUSHION	
21	S38006001	1	イトキリクドウレバークミ	TR. TRIMMER DRIVING LEVER ASSY	
21-1	S38007001	1	イトキリクドウレバー	DRIVING LEVER, THREAD TRIMMER	
21-2	153597001	1	シタイトサバキカラー	RETAINER COLLAR, LOWER THREAD	
21-3	S30033001	1	ダンネジ3.57	SHOULDER SCREW, SM3.57	
21-4	148813001	2	ザガネ	WASHER	
21-5	106129002	1	ナツト3.57	NUT, SM3.57	
21-6	028350242	1	バネザガネ2-3.5	WASHER, SPRING 2-3.5	
22	014770622	1	アナトメネジ6.35クボミ	SET SCREW, SOCKET (CP) SM6.35	
23	S02354001	1	タマツギテダンネジB	SHOULDER SCREW, B	
24	100022005	1	ナツト5.95	NUT, SM5.95	
25	S42886101	1	イトキリロツドSクミ	THREAD TRIMMER ROD ASSY, S	
25-1	S42887101	1	イトキリロツドS	THREAD TRIMMER ROD, S	
25-2	141492001	1	タマツギテクミ	JOINT ASSY	
25-3	106588003	1	ナツト5.95	NUT, SM5.95	
26	110233001	1	ダンネジ4.76	SHOULDER SCREW, SM4.76	
27	109893002	1	ザガネ	WASHER	
28	110161004	1	ナツト4.76	NUT, SM4.76	
29	S38010001	1	イトキリレバー	LEVER, THREAD TRIMMER	
30	S10195001	1	イトキリレバークミ	LEVER SHAFT	
31	110367001	1	ザガネ	WASHER, PLAIN SPECIAL 8	
32	048060342	1	トメワE6	RETAINING RING, E6	
33	014760622	1	アナトメネジ5.95	SET SCREW, SOCKET SM5.95	
34	S38011001	1	イトキリモドシバネ	SPRING, EXTENSION	
35	158940001	1	バネカケ	SPRING HOOK	
36	110233001	1	ダンネジ4.76	SHOULDER SCREW, SM4.76	
37	110161004	1	ナツト4.76	NUT, SM4.76	
38	153484001	1	ザガネ4.76	WASHER, PLAIN 4.76	
39	025680232	1	ヒラザガネチユウ4.37	WASHER, PLAIN M 4.37	
40	S42856001	1	レンカンレバークミ	CONNECTING ROD LEVER ASSY	
41	S10202101	1	レンカンレバークミ	CONNECTING ROD LEVER SHAFT	
42	014680422	1	アナトメネジ4.37クボミ	SET SCREW, SOCKET (CP) SM4.37	
43	S44380001	1	ハリイタ	NEEDLE PLATE	
44	S10204101	1	イトキリレンカン	THREAD TRIMMER CONNECTING ROD	
45-1	S10205001	1	イドウハクミ	MOVABLE KNIFE ASSY	
46	S10208001	1	イドウハカンザ t=0.4	SPACER, MOVABLE KNIFE T = 0.4 t=0.4	
46	S10208002	1	イドウハカンザ t=0.5	SPACER, MOVABLE KNIFE T = 0.5 t=0.5	

From the library of: Diamond Needle Corp

J. 糸切り関係 / Thread trimmer mechanism / Fadenabschneidevorrichtung
 / M canisme de coupe-fil / Mecanismo de la cortadura de hiros

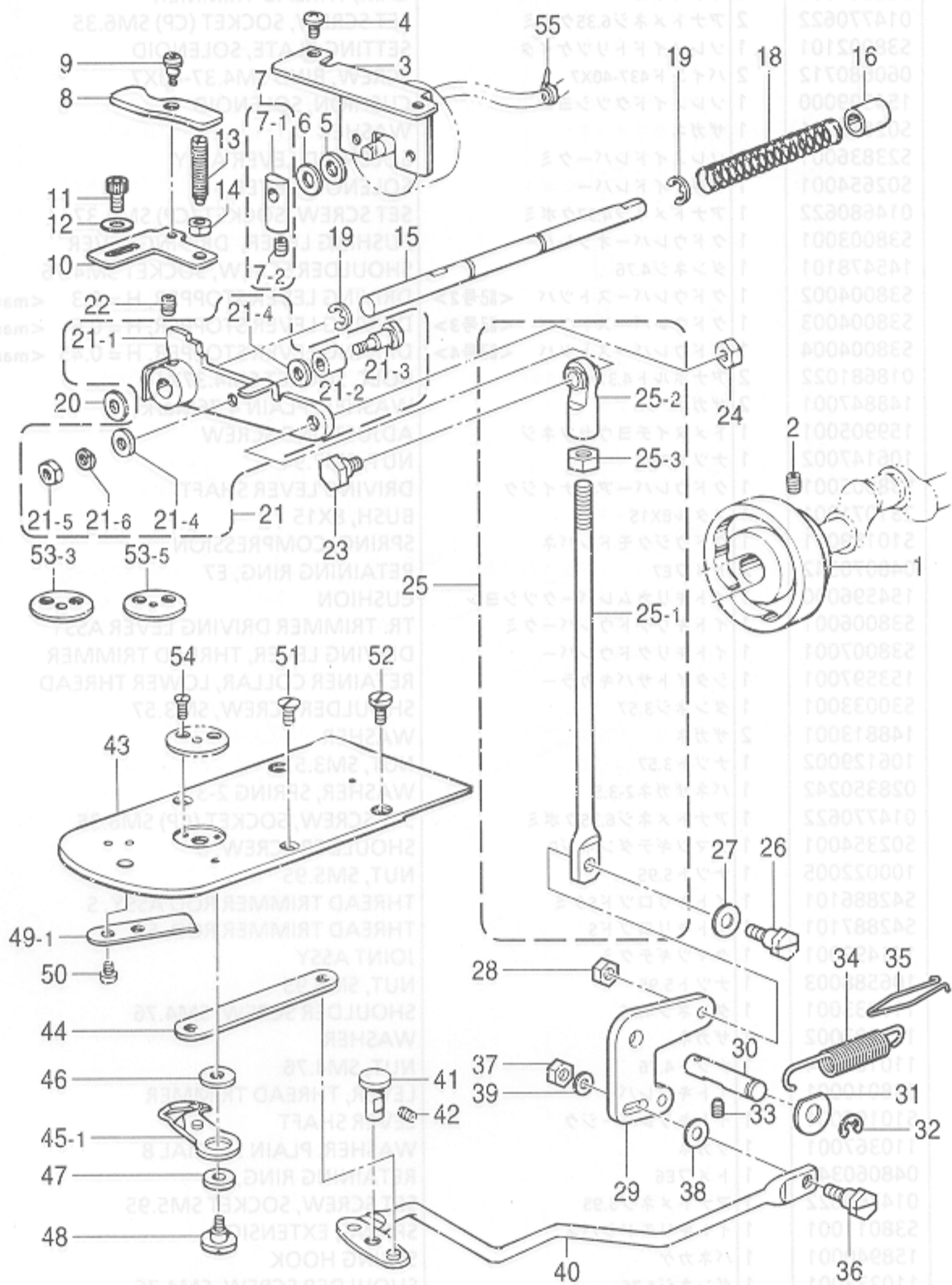

From the library of: Diamond Needle Corp

" オプション部品 / OPTION PARTS "

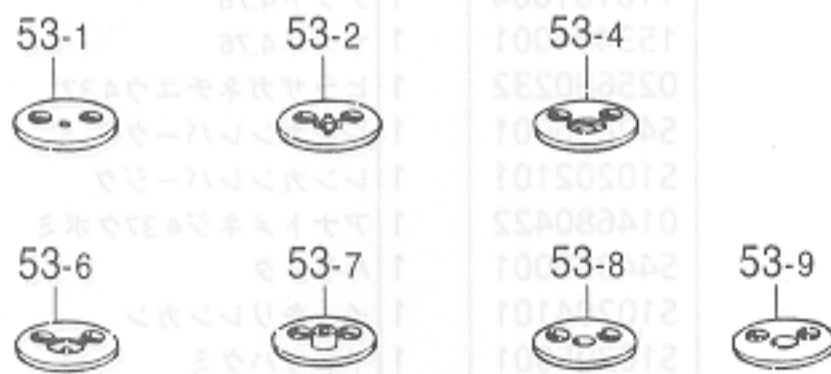
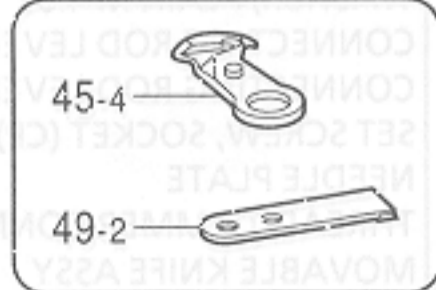

J. 糸切り関係 / Thread trimmer mechanism / Fadenabschneidevorrichtung
 / Mécanisme de coupe-fil / Mecanismo de la cortadura de hiros

REF.NO.	CODE	Q'TY	ヒンメイ	NAME OF PARTS	RM
46	S10208003	1	イドウハカンザ t=0.6	SPACER, MOVABLE KNIFE T = 0.6 t=0.6	
47	S00705001	1	イドウハカラー	COLLAR, MOVABLE KNIFE	
48	S10209101	1	シメネジ4.37	SCREW, SM4.37	
49-1	S10210201	1	コテイハ	FIXED KNIFE	
50	111140002	2	シメネジ2.38	SCREW, SM2.38	
51	100032004	2	サラネジ4.37	SCREW, FLAT SM4.37	
52	106629002	2	シメネジ4.37	SCREW, SM4.37	
53-3	S10212101	1	<厚物用> ハリアナイタE ø2.6	<For Heavy-weight materials> NEEDLE HOLE PLATE, E ø2.6	
53-5	S10213001	1	<中厚物用> ハリアナイタF ø2.2	<For Medium-weight materials> NEEDLE HOLE PLATE, F ø2.2	
54	100360003	2	サラネジ2.38	SCREW, FLAT SM2.38	
55	228475000	1	ケツソクバンド1.9X80	FASTENING BAND, 1.9X80	
45-2	S40934101	1	" オプション部品 " イドウハLクミ	" OPTION PARTS " MOVABLE KNIFE ASSY, L	
45-3	S40846001	1	イドウハWPクミ	MOVABLE KNIFE ASSY, WP	
45-4	S31612001	1	イドウハクミ	MOVABLE KNIFE ASSY	
49-2	S30128001	1	コテイハチヨウコウ	FIXED KNIFE, HARD MATERIAL	
53-1	S10211001	1	ハリアナイタA ø1.6	NEEDLE HOLE PLATE, A ø1.6	
53-2	S29997001	1	ハリアナイタD ø2.6	NEEDLE HOLE PLATE, D ø2.6	
53-4	S30925001	1	ハリアナイタED ø3.4	NEEDLE HOLE PLATE, ED ø3.4	
53-6	S30926001	1	ハリアナイタFD ø2.2	NEEDLE HOLE PLATE, FD ø2.2	
53-7	S30450001	1	ハリアナイタH ø2.6	NEEDLE HOLE PLATE, H ø2.6	
53-8	S25127001	1	ハリアナイタL ø3.3	NEEDLE HOLE PLATE, L ø3.3	
53-9	S34348001	1	ハリアナイタM ø4.0	NEEDLE HOLE PLATE, M ø4.0	
	S42859001	1	ワイパーアーム	WIPER ARM ASSY	
	S42864101	1	ワイパー	THREAD WIPER, A	
	156206001	1	シメネジ2.38	SCREW, SM3.57X10	
	S13385001	1	アタメネジ2.38	SET SCREW, SOCKET (CP) SM2.38	
	014710522	1	ワッシャー	WASHER	
	S21875001	1	カラー	COLLAR	
	S12668001	1	ナット2	NUT, 2 SM3.57	
	021670202	1	シメネジ3.18	SHOULDER SCREW, SM3.18	
	100659001	1	ナット1	NUT, 1 SM3.18	
	021660102	1	コイルスプリング	SPRING	

From the library of: Diamond Needle Corp

K. 糸払イ関係 / Thread wiper mechanism / Fadenwischvorrichtung / M canisme de tire-fil / Mecanismo del limpiador de hilo

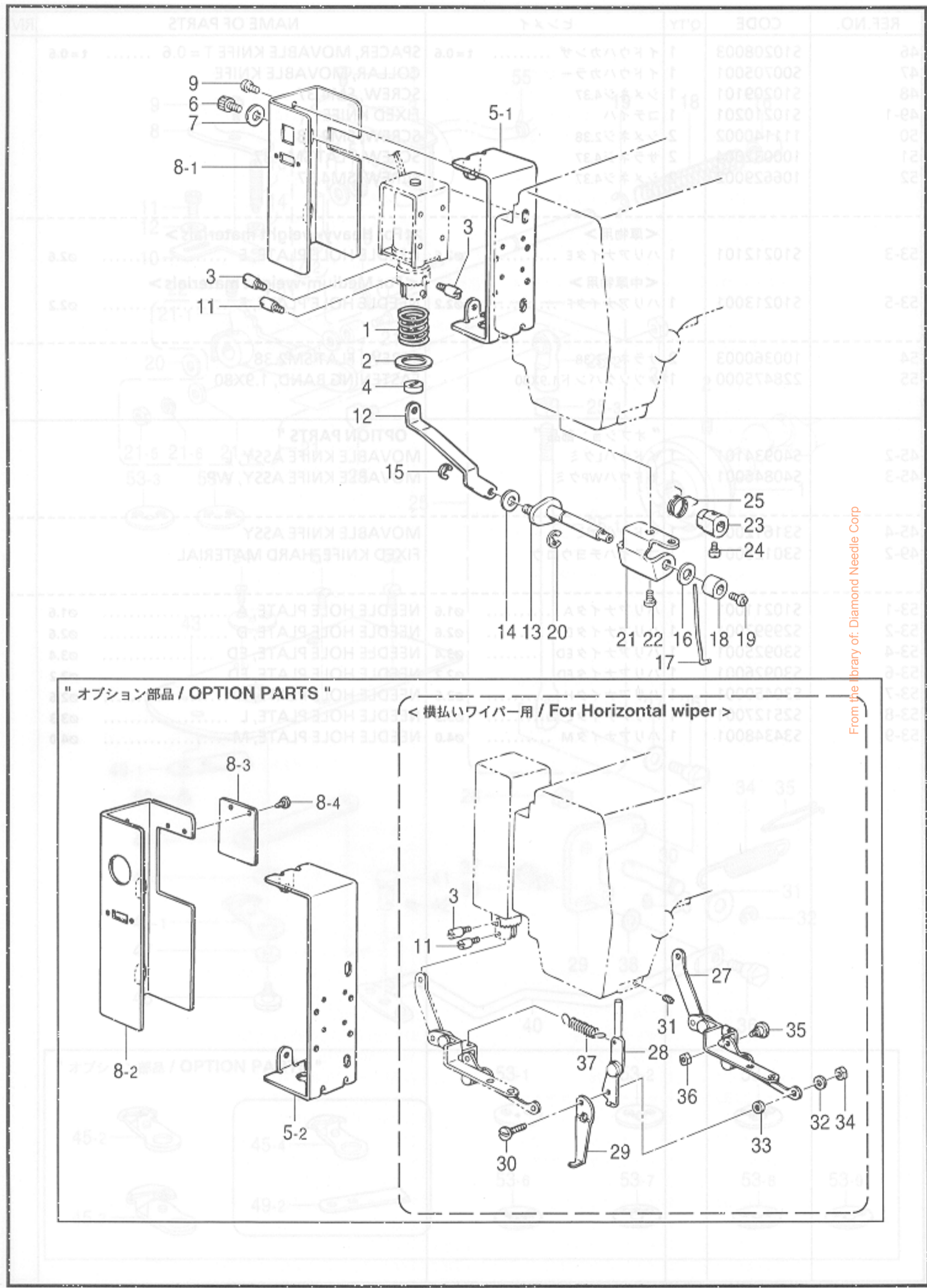

From the library of: Diamond Needle Corp

K. 糸払イ関係 / Thread wiper mechanism / Fadenwischvorrichtung / Mécanisme de tire-fil / Mecanismo del limpiador de hilo

REF.NO.	CODE	Q'TY	ヒンメイ	NAME OF PARTS	RM
1	S41206001	1	イトハライバネ	SPRING, THREAD WIPER	
2	S41205001	1	ヒラザガネ	WASHER, PLAIN	
3	S25456001	2	プランジヤピン	PLUNGER PIN	
4	S41207000	1	スパーサゴム	SPACER RUBBER	
5-1	S10214109	1	ソレノイドトリツケイタ	SETTING PLATE, SOLENOID	
6	018681022	2	アナボルト4.37X10	BOLT, SOCKET SM4.37X10	
7	100645003	2	ザガネ	WASHER	
8-1	S10215109	1	ソレノイドカバー	SOLENOID COVER	
9	062680512	2	ナベコ437-40X5	SCREW, PAN SM4.37-40X5	
11	S25456001	1	プランジヤピン	PLUNGER PIN	
12	S42858001	1	イトハライレンカン	THREAD WIPER CONNECTING ROD	
13	S10217001	1	イトハライクランククミ	THREAD WIPER CRANK ASSY	
14	110735001	1	ザガネ	WASHER	
15	048030342	1	トメワE3	RETAINING RING, E3	
16	025750132	1	ヒラザガネシヨウ5.56	WASHER, PLAIN S 5.56	
17	S10470101	1	ワイパー	WIPER	
18	146288001	1	イトハライジクカラー	COLLAR, THREAD WIPER STUD	
19	060680512	1	バインド437-40X5	SCREW, BIND SM4.37-40X5	
20	048040342	1	トメワE4	RETAINING RING, E4	
21	S02672002	1	イトハライジクウケイタ	SUPPORT, T-WIPER STUD	
22	062680512	2	ナベコ437-40X5	SCREW, PAN SM4.37-40X5	
23	S02677001	1	セットカラー	SET SCREW COLLAR	
24	144458001	1	アタマツキトメネジ3.57	SET SCREW, SM3.57	
25	S02678001	1	ワイパーバネ	SPRING	
5-2	S37147109	1	ソレノイドトリツケイタE	SETTING PLATE, E SOLENOID	
8-2	S37148109	1	ソレノイドカバーE	SOLENOID COVER, E	
8-3	S37806109	1	ソレノイドカバーEフタ	SOLENOID COVER LID, E	
8-4	008400604	2	+トラスコ4X6	SCREW, TRUSS M4X6	
27	S42859001	1	イトハライレンカンヨコクミ	T-WIPER CONNECTING ROD ASSY, S	
28	S42864101	1	ワイパーウデクミ	WIPER ARM ASSY	
29	156206001	1	ワイパーA	THREAD WIPER, A	
30	S13385001	1	シメネジ3.57X10	SCREW, SM3.57X10	
31	014710522	1	アタメネジ4.76クボミ	SET SCREW, SOCKET (CP) SM4.76	
32	S21875001	1	ザガネ	WASHER	
33	S12668001	1	カラー	COLLAR	
34	021670202	1	ナツト2シユ3.57	NUT, 2 SM3.57	
35	100659001	1	ダンネジ3.18	SHOULDER SCREW, SM3.18	
36	021660102	1	ナツト1シユ3.18	NUT, 1 SM3.18	
37	159111001	1	Cクラツチアンナイバネ	SPRING	

From the library of: Diamond Needle Corp

L. 糸締メ関係 / Thread nipper mechanism / Fadenspannvorrichtung / M canisme de pince-fil / Mecanismo de la mordaza para hilo

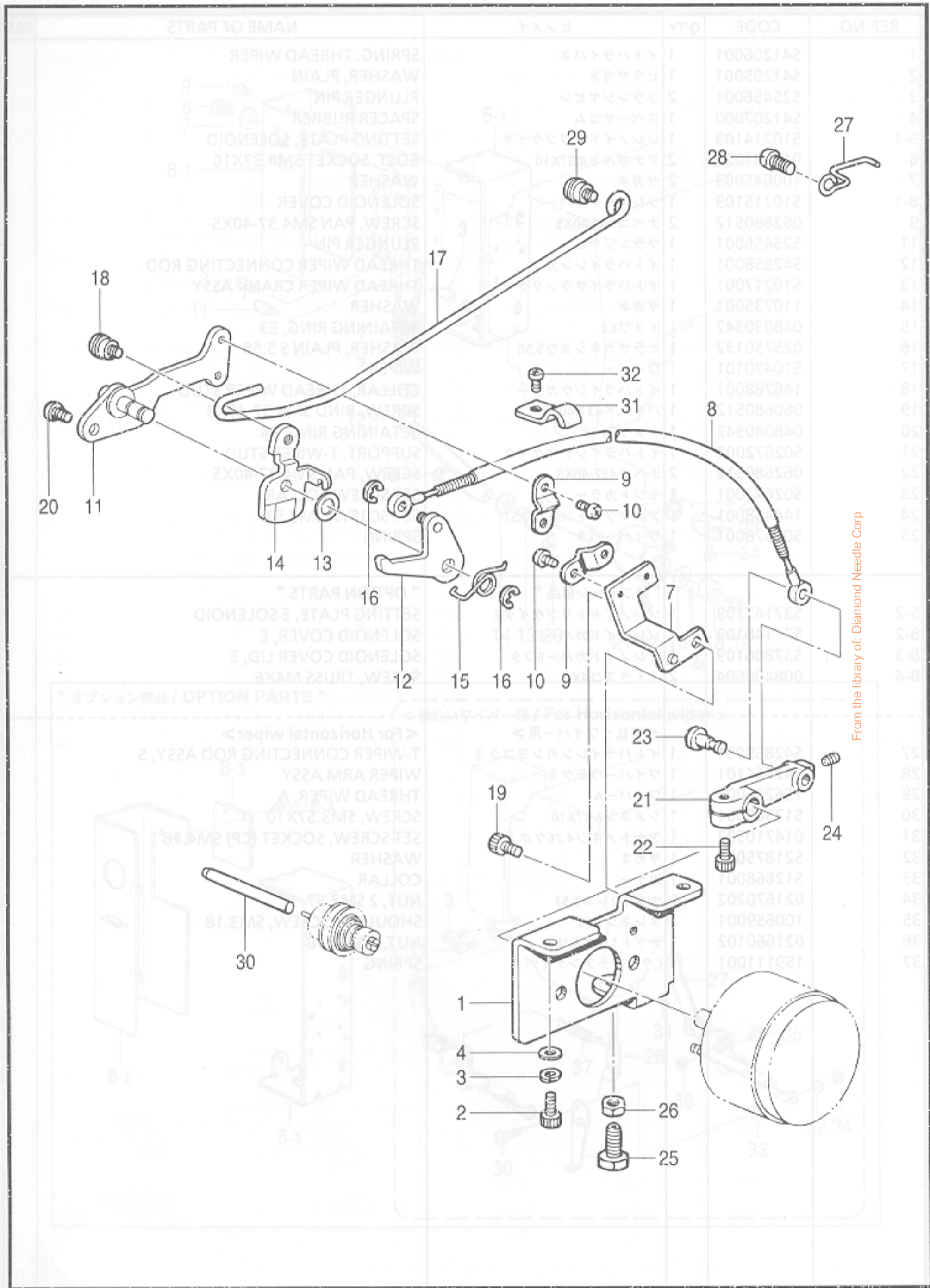

From the library of: Diamond Needle Corp

L. 糸締メ関係 / Thread nipper mechanism / Fadenspannvorrichtung / Mécanisme de pince-fil / Mecanismo de la mordaza para hilo

REF.NO.	CODE	Q'TY	ヒンメイ	NAME OF PARTS	RM
1	S10219001	1	ソレノイドトリツケイタ	SETTING PLATE, SOLENOID	
2	018061422	2	アナボルト6X14	BOLT, SOCKET M6X14	
3	028060242	2	バネザガネ2-6	WASHER, SPRING 2-6	
4	109893002	2	ザガネ	WASHER	
7	S10221001	1	ワイヤササエ	WIRE SUPPORT	
8	S42868001	1	オサエアゲワイヤクミ	WIRE ASSY, WORK CLAMP LIFTER	
9	154607101	2	イトユルメワイヤーオサエD	WIRE HOLDER, D	
10	062670612	4	ナベコ357-40X6	SCREW, PAN SM3.57-40X6	
11	S42870101	1	イトユルメラケット	TENSION RELEASE BRACKET	
12	S42871101	1	オサエアシアゲレバークミ	WORK CLAMP LIFTER LEVER ASSY	
13	109763002	1	ザガネ	WASHER	
14	S42873101	1	イトユルメラバー	LEVER, TENSION RELEASE	
15	S10229101	1	オサエレバーバネ	SPRING	
16	048040342	3	トメワE4	RETAINING RING, E4	
17	S42874001	1	イトユルメロツド	ROD, TENSION RELEASE	
18	145478101	1	ダンネジ4.76	SHOULDER SCREW, SOCKET SM4.76	
19	018060822	1	アナボルト6X8	BOLT, SOCKET M6X8	
20	062771012	1	ナベコ635-40X10	SCREW, PAN SM6.35-40X10	
21	S10230000	1	オサエアゲレバー	LIFTER LEVER	
22	018501422	1	アナボルト5X14	BOLT, SOCKET M5X14	
23	S10231001	1	ツバツキジク5.5	FLANGED SHAFT, 5.5	
24	014680622	1	アナトメネジ4.37クボミ	SET SCREW, SOCKET (CP) SM4.37	
25	017822212	1	ボルト7.94X22	BOLT, SM7.94X22	
26	106147002	1	ナツト7.94	NUT, SM7.94	
27	S10232001	1	ケーブルササエ	CABLE SUPPORT	
28	062760812	1	ナベコ595-28X8	SCREW, PAN SM5.95-28X8	
29	145478101	1	ダンネジ4.76	SHOULDER SCREW, SOCKET SM4.76	
30	S10239001	1	イトユルメボウ	TENSION RELEASE STUD	
31	140647101	1	コードオサエ	CORD HOLDER	
32	062670612	1	ナベコ357-40X6	SCREW, PAN SM3.57-40X6	
1-29-1	538177000	1	CM17520	TRANSISTOR, :25K1938	
1-29-2	538200000	2	DS1938	SURGE ABSORBER, DSA362MA	
1-29-3	232384001	1	DS362MA	VARIATOR, V14D471	
1-29-4	538201000	2	SAFB	FUSE, 5A FB	
1-29-5	508030000	2	SAFA	FUSE, 6A	
1-29-6	153242000	2	SEA	BOLT, SOCKET M6X14	
4	018061036	4	アナボルト6X10	WASHER, SPRING 2-6	
5	028060242	4	バネザガネ2-6	WASHER	
6	109893002	4	ザガネ	WASHER	
7	S10221001	1	ワイヤササエ	WIRE ASSY, MOTOR	
10	S43190001	1	ワイヤササエ	WIRE ASSY, MOTOR	
20	S38352101	2	イトユルメボウ	SHOES & LANG. S-S	
21	S38353101	2	イトユルメボウ	SHOCK JAP.	
2-1	S38112001	1	デンゲンSWク	3-phase 200V AC & 220V AC P-SWITCH SWITCH ASSY, A 3-P. 200/220V AC	

From the library of: Diamond Needle Corp

M. コントロールボックス関係 / Control box mechanism / Schaltkasten
 / M canisme du bo tier de contr le / Mecanismo de la caja de controles

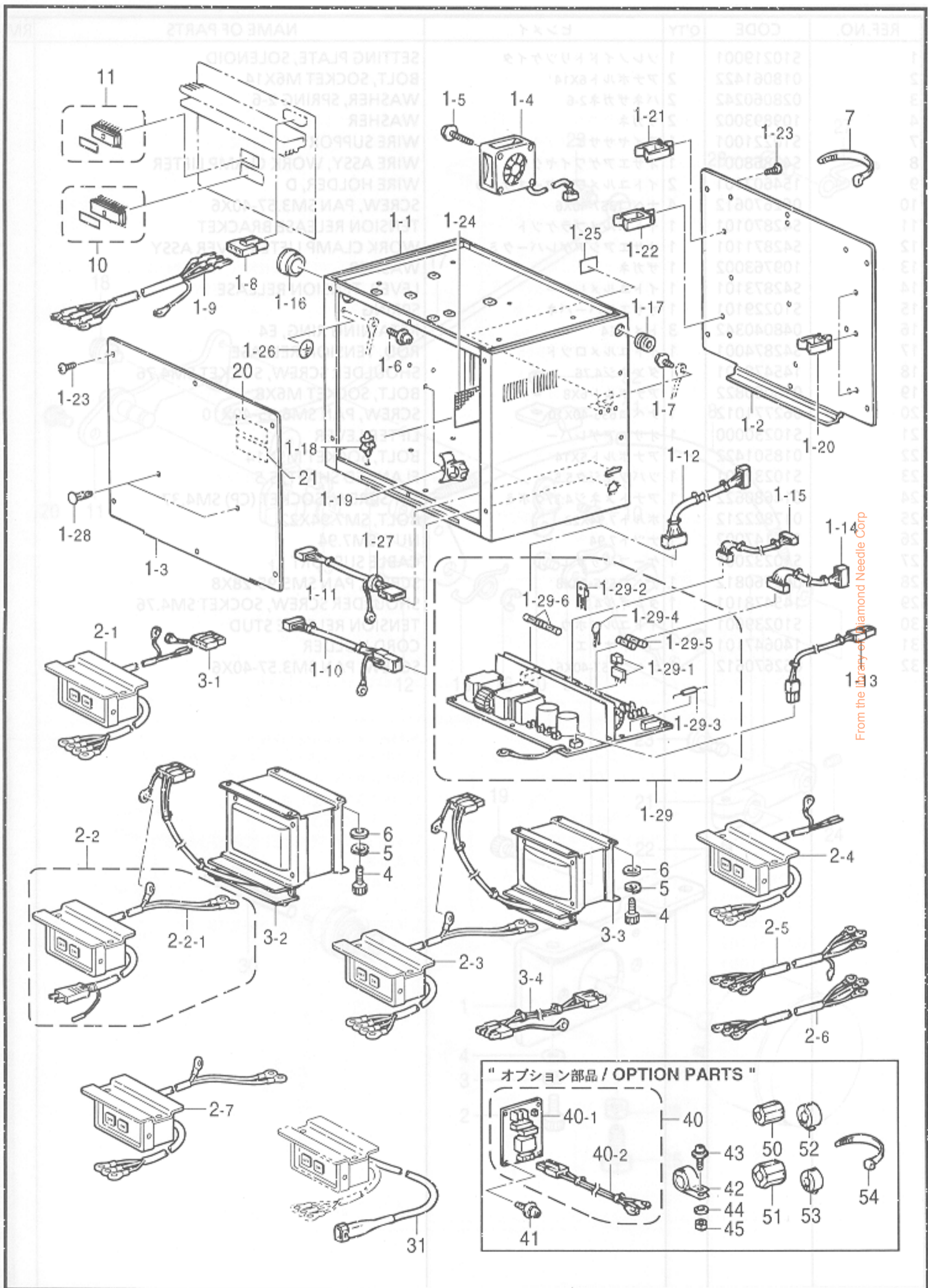

From the Library of Diamond Needle Corp

M. コントロールボックス関係 / Control box mechanism / Schaltkasten
/ Mécanisme du boîtier de contrôle / Mecanismo de la caja de controles

REF.NO.	CODE	Q'TY	ヒンメイ	NAME OF PARTS	RM
1	S43169009	1	ボックスクミ	BOX ASSY	
1-1	S43170009	1	デンゲンボックス	POWER SUPPLY BOX	
1-2	S43171009	1	キバントリツケイタ	SETTING PLATE, PCB	
1-3	S43172009	1	ボックスフタ	BOX COVER	
1-4	S38094100	2	DCファンモータクミ	DC FAN MOTOR ASSY	
1-5	0A5403006	6	+ナベザクミ 4X30DB	SCREW, PAN (S/P WASHER) M4X30	
1-6	0A5400806	1	+ナベザクミ 4X8DB	SCREW, PAN (S/P WASHER) M4X8	
1-7	0A5401006	3	ナベコバネヒラ 4X10	SCREW, PAN (S/P WASHER) M4X10	
1-8	S16568000	1	コネクタ 3191-03R1	CONNECTOR, 3191-03R1	
1-9	S38122200	1	モータケーブルクミ	MOTOR HARNESS ASSY, E	
1-10	S42260000	1	フットSWコード 434クミ	FOOT SWITCH HARNESS ASSY, 434	
1-11	S43183100	1	パネルコードBクミ	PANEL HARNESS ASSY, B	
1-12	S38107100	1	セイギヨデンゲンコード	POWER SUPPLY HARNESS, CONTROL	
1-13	S38108000	1	モータデンゲンコード	MOTOR POWER SUPPLY HARNESS	
1-14	S38109100	1	ゲートデンゲンコード	POWER SUPPLY HARNESS, H-P	
1-15	S38110000	1	PERコード	PER HARNESS	
1-16	S43274000	1	ブツシユTB-2938	BUSH, TB-2938	
1-17	S43186000	1	ブツシユBU687B	BUSH, BU687B	
1-18	S00554000	18	サポート 6NS	SUPPORT, 6NS	
1-19	S31760000	1	CKSクランプ 26L	CORD CLAMP, 26-L	
1-20	S43275000	7	コードクランプ WS2NS	CORD CLAMP, WS2NS	
1-21	S43276000	3	コードクランプ WS3NS	CORD CLAMP, WS3NS	
1-22	S43277000	1	コードクランプ WS4NS	CORD CLAMP, WS4NS	
1-23	008400604	12	+トラスコ 4X6	SCREW, TRUSS M4X6	
1-24	S43309000	1	ポウジンアミ	FRAGMENT PROTECTOR NET	
1-25	S37059001	1	PEマーク	LABEL, PE	
1-26	S37060001	1	アースマーク	LABEL, GROUNDING	
1-27	S42653000	1	コア TFC-23-11-14	CORE, TFC-23-11-14	
1-28	S34413000	2	スパーサー	SPACER	
1-29	S43173001	1	デンゲンキバンクミ	POWER SUPPLY PCB ASSY	
1-29-1	S43177000	1	ICMA3830	IC, :MA3830	
1-29-2	S38200000	2	MOSFET 2SK1938	TRANSISTOR, :2SK1938	
1-29-3	232384001	1	Sアブソバ DSA362MA	SURGE ABSORBER, DSA362MA	
1-29-4	S38201000	2	バリスタ V14D471	VARISTOR, V14D471	
1-29-5	S08030000	2	Gヒューズ 5AFB	FUSE, 5A FB	
1-29-6	153242000	2	ヒューズ 6A	FUSE, 6A	
4	018061036	4	アナボルト 6X10	BOLT, SOCKET M6X10	
5	028060246	4	バネザガネ 2-6	WASHER, SPRING 2-6	
6	025060236	4	ヒラザガネチユウ 6	WASHER, PLAIN M 6	
7	228475000	4	ケツソクバンド 1.9X80	FASTENING BAND, 1.9X80	
10	S43190000	1	PROMセイギヨクミ	PROM ASSY, CONTROL	
11	S43191000	1	PROMモータクミ	PROM ASSY, MOTOR	
20	S38352101	2	デンゲキラベル 4カコク	LABEL, ELEC. SHOCK 4 LANG.	
21	S38353101	2	デンゲキラベル 7	LABEL, ELEC. SHOCK JAP.	
2-1	S38112001	1	<三相200V, 220V用> デンゲンSWクミA	<For 3-phase 200V AC & 220V AC> P-SUPPLY SWITCH ASSY, A 3-P. 200/220V AC	

From the library of: Diamond Needle Corp

151-V26-502

- ☆ RM欄に※が付いている部品をご注文頂きますと、基板等必要な部品が一式入ったセットになっております。
- ☆ When ordering parts which have an asterisk (※) in the RM column, these parts will be supplied as a set together with other necessary parts such as circuit boards.
- ☆ Bei Bestellung von Teile mit einem Asterrikus (※) aus der Kolonne RM werden diese Teile als Saatz, zusammen mit anderen notwendigen tilen, wie Schaltplatimen geliefert.
- ☆ Si l'on commande des pièces désignées par un astérisque (※) dans la colonne RM, ces pièces seront fournies en jeu avec les autres pièces nécessaires telles que des plaquettes.
- ☆ Al ordenar partes que tienen un asterisco (※) en la columna RM, estas partes serán suministradas como un juego junto con otras partes necesarias como los tableros de circuitos.

M. コントロールボックス関係 / Control box mechanism / Schaitkasten
/ Mécanisme du boîtier de contrôle / Mecanismo de la caja de controles

REF.NO.	CODE	Q'TY	ヒンメイ	NAME OF PARTS	RM
2-2	S38114000	1	<100V 国内用> デンゲンSWクミB	<For only Japan>	
2-2-1	S38115000	1	デンゲンINコードB		
2-3	S38117000	1	<三相380V, 415V用> デンゲンSWクミC	<For "3-phase 380V AC & 415V AC"> POWER SUPPLY SWITCH ASSY, C	
2-4	S47592000	1	<単相220V用> デンゲンSWクミD	<For "1-phase 220V AC"> P-SUPPLY SWITCH ASSY, D 1-P. 220V AC	
2-5	S38120000	1	<三相400V用> デンゲンINコードE	<For "3-phase 400V AC"> POWER SUPPLY HARNESS, E IN	
2-6	S43188000	1	<単相230V用> デンゲンINコードF	<For "1-phase 230V AC"> POWER SUPPLY IN HARNESS, F	
2-7	S47594000	1	<単相110V, 240V用> デンゲンSWクミG	<For "1-phase 110V AC & 240V AC"> P-SUPPLY SWITCH ASSY, G 1-P. 110/240V AC	
3-1	S38123000	1	<200V, 220V用> ACINコネクタクミ	<For "200V AC & 220V AC"> AC IN CONNECTOR ASSY	
3-2	S43369000	1	<100V, 110V用> ヘンカントランスBクミ	<For "100V AC & 110V AC"> CONVERSION TRANSFORMER ASSY, B	
3-3	S43370000	1	<280V, 380V, 400V, 415V用> ヘンカントランスCクミ	<For 280V AC, 380V AC, 400V AC & 415V AC"> CONVERSION TRANSFORMER ASSY, C	
3-4	S43201000	1	<単相230V用> ACINコードF	<For "1-phase 230V AC"> AC IN HARNESS, F	
31	S43278000	1	<コンプレッサユニット用> コンプレッサハーネス	<For Compressor unit> COMPRESSOR HARNESS	
40	S40635001	1	" オプション部品 "	" OPTION PARTS "	
40-1	S40616001	1	ノイズフィルタ430Eクミ	NOISE FILTER ASSY, 430E	
40-2	S40624000	1	ノイズフィルタEMCクミ	NOISE FILTER ASSY, EMC	
41	0A4400605	4	ノイズフィルタハーネスA	NOISE FILTER HARNESS, A	
42	S40623000	1	+ナベザクミ4X6DA	SCREW, PAN (S/P WASHER) M4X6	
43	S40623000	1	EMIコアTR-40-27	EMI CORE, TR-40-27	
44	0A5401605	1	+ナベザクミ4X16DB	SCREW, PAN (S/P WASHER) M4X16	
45	025040236	1	ヒラザガネチユウ4	WASHER, PLAIN M 4	
45	021400106	1	ナツト1シユ4	NUT, 1 M4	
50	S40621000	1	EMIコアESD-SR-15	EMI CORE, ESD-SR-15	
51	S40622000	1	EMIコアESD-SR-25	EMI CORE, ESD-SR-25	
52	S40764000	7	コアTFC25-15-12	CORE, TFC25-15-12	
53	S42653000	2	コアTFC-23-11-14	CORE, TFC-23-11-14	
54	149809000	12	タイラツPL	BEAD BAND, L = 200	

From the library of: Diamond Needle Corp

151-V26-502

☆ RM欄に※が付いている部品をご注文頂きますと、基板等必要な部品が一式入ったセットになっております。

☆ When ordering parts which have an asterisk (*) in the RM column, these parts will be supplied as a set together with other necessary parts such as circuit boards.

☆ Bei Bestellung von Teile mit einem Asterrikus (*) aus der Kolonne RM werden diese Teile als Saatz, zusammen mit anderen notwendigen tilen, wie Schaltplatimen geliefert.

☆ Si l'on commande des pièces désignées par un astérisque (*) dans la colonne RM, ces pièces seront fournies en jeu avec les autres pièces nécessaires telles que des plaquettes.

☆ Al ordenar partes que tienen un asterisco (*) en la columna RM, estas partes serán suministradas como un juego junto con otras partes necesarias como los tableros de circuitos.

M. コントロールボックス関係 / Control box mechanism / Schaltkasten
/ Mécanisme du boîtier de contrôle / Mecanismo de la caja de controles

REF.NO.	CODE	Q'TY	ヒンメイ	NAME OF PARTS	RM
			" 補給用部品 "	" For Supply parts "	
H-1	S43241009	1	<200V, 220V用> ボックスソウクミA1	<For "200V AC & 220V AC"> POWER SUPPLY BOX ASSY, A1	※
H-2	S43242009	1	<100V 国内用> ボックスソウクミB1	<For only Japan> -----	※
H-3	S43243009	1	<三相415V用> ボックスソウクミC1	<For "3-phase 415V AC"> POWER SUPPLY BOX ASSY, C1	※
H-4	S43245009	1	<単相220V, 230V用> ボックスソウクミA2	<For "1-phase 220V AC & 230V AC"> POWER SUPPLY BOX ASSY, A2	※
H-5	S43246009	1	<三相400V用> ボックスソウクミE	<For "3-phase 400V AC"> POWER SUPPLY BOX ASSY, E	※
H-6	S43244009	1	<三相380V用> ボックスソウクミC2	<For "3-phase 380V AC"> POWER SUPPLY BOX ASSY, C2	※
H-7	S43247009	1	<単相230V用> ボックスソウクミF	<For "1-phase 230V AC"> POWER SUPPLY BOX ASSY, F	※
H-8	S43248009	1	<単相110V用> ボックスソウクミB2	<For "1-phase 110V AC"> POWER SUPPLY BOX ASSY, B2	※
H-9	S43240009	1	<単相240V用> ボックスソウクミC3	<For "1-phase 240V AC"> POWER SUPPLY BOX ASSY, C3	※

From the library of: Diamond Needle Corp

151-V26-502

- ☆ RM欄に※が付いている部品をご注文頂きますと、基板等必要な部品が一式入ったセットになっております。
- ☆ When ordering parts which have an asterisk (※) in the RM column, these parts will be supplied as a set together with other necessary parts such as circuit boards.
- ☆ Bei Bestellung von Teile mit einem Asteriskus (※) aus der Kolonne RM werden diese Teile als Saatz, zusammen mit anderen notwendigen telen, wie Schaltplatimen geliefert.
- ☆ Si l'on commande des pièces désignées par un astérisque (※) dans la colonne RM, ces pièces seront fournies en jeu avec les autres pièces nécessaires telles que des plaquettes.
- ☆ Al ordenar partes que tienen un asterisco (※) en la columna RM, estas partes serán suministradas como un juego junto con otras partes necesarias como los tableros de circuitos.

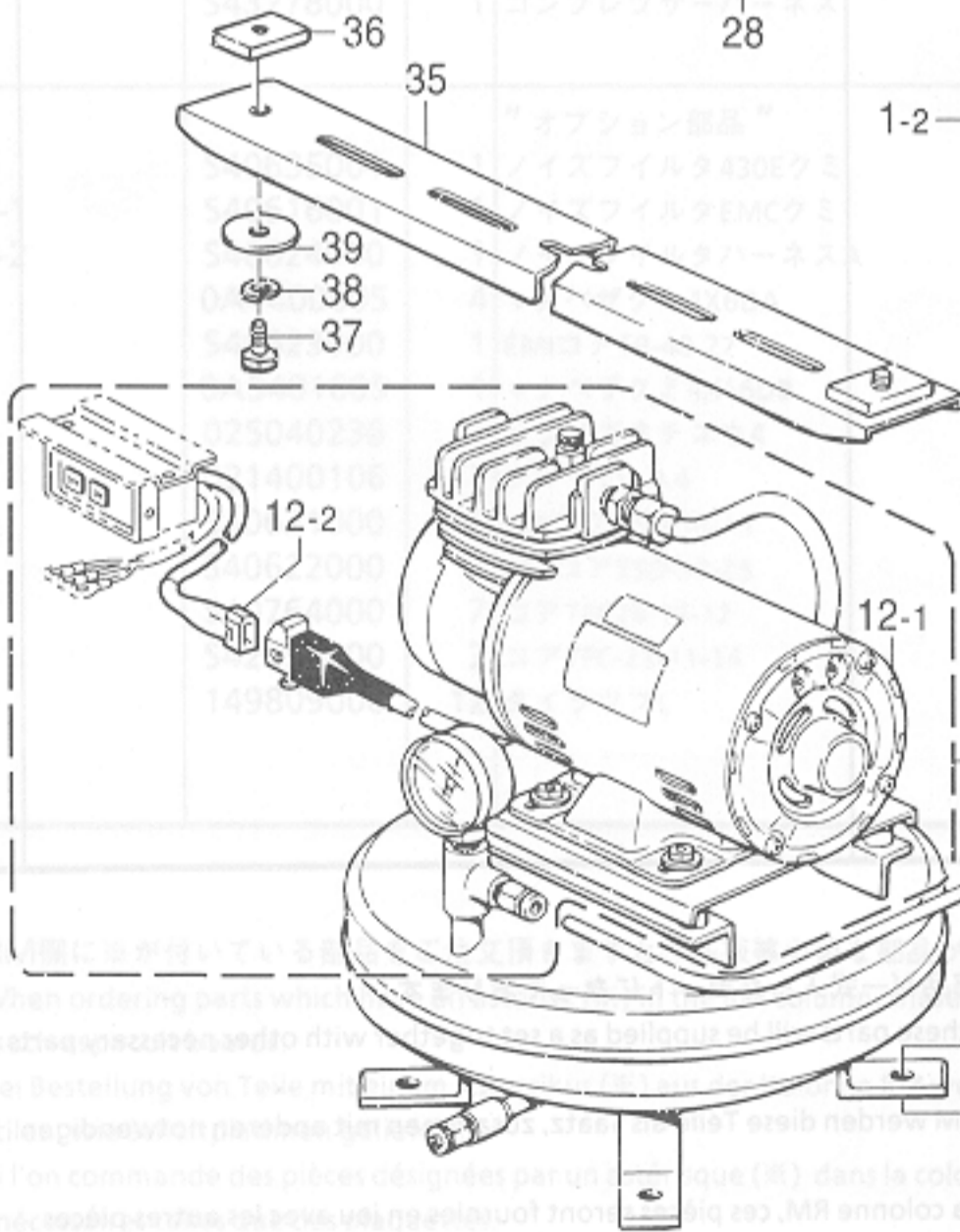
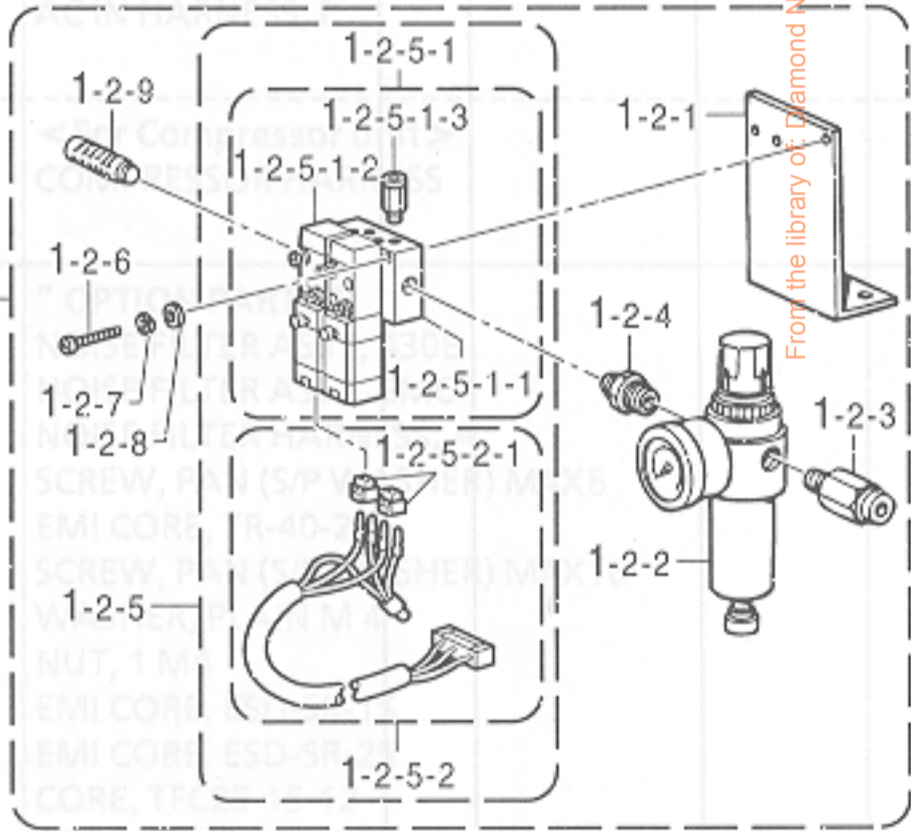
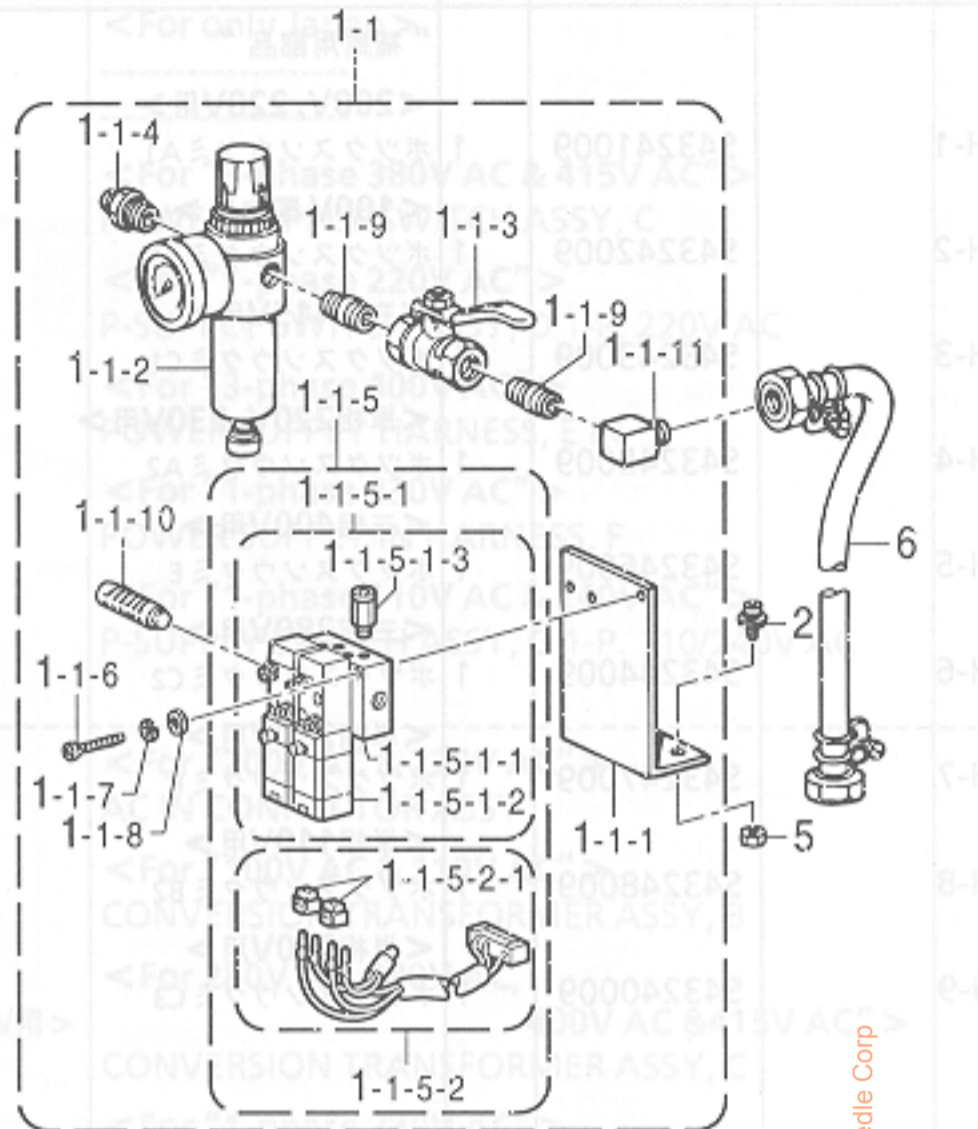
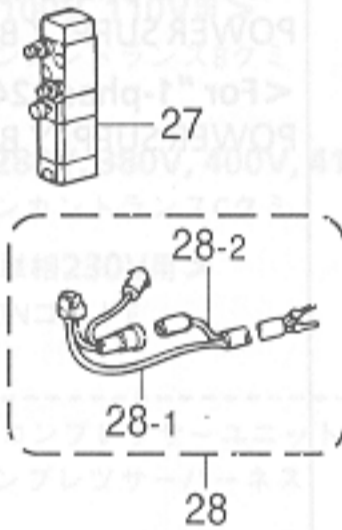
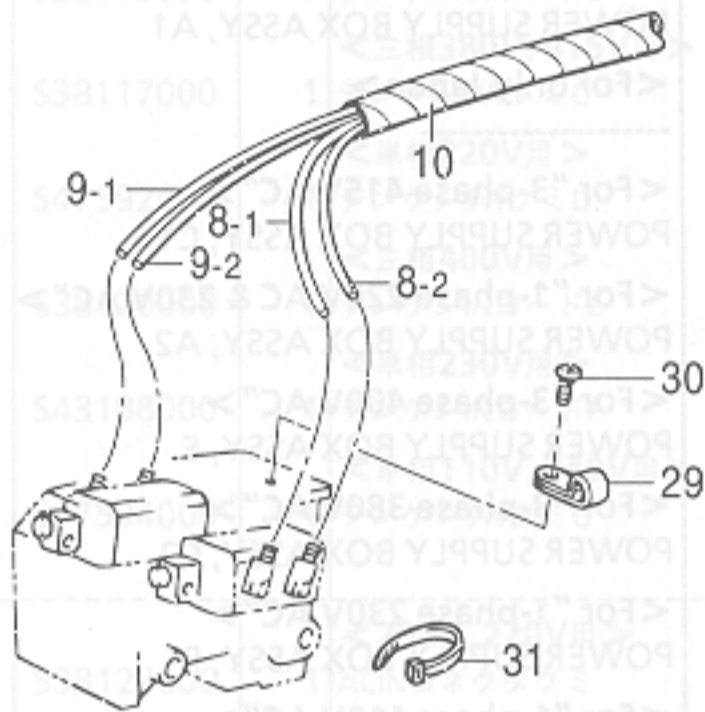

From the library of: Diamond Needle Corp

N. 空圧関係 / Air pressure mechanism / Luftdruck / Mécanisme de la pression d'air
/ Mecanismo de la presión de aire

REF.NO.	CODE	Q'TY	ヒンメイ	NAME OF PARTS	RM
			<コンプレッサー無し仕様用>	<For with-out Compressor>	
1-1	S43678009	1	デンジバルブ2Aクミ	SOLENOID VALVE ASSY, 2A	
1-1-1	S31551009	1	バルブトリツケイタ2-3	VALVE SETTING PLATE, 2-3	
1-1-2	S09318101	1	インテグレータ	INTEGRATER	
1-1-3	S40628000	1	ボールバルブ1/4	BALL VALVE, 1/4	
1-1-4	S09228000	1	イケイニツブル	NIPPLE, 1/4X1/8	
1-1-5	S43679001	1	デンジバルブ2クミ	SOLENOID VALVE ASSY, 2	
1-1-5-1	S43680001	1	エアマニホルドクミ	AIR MANIFOLD ASSY	
1-1-5-1-1	S43684001	1	エアマニホルド	AIR MANIFOLD	
1-1-5-1-2	S43683001	2	デンジバルブ	SOLENOID VALVE	
1-1-5-1-3	S18415101	4	ハーフユニオンQ4M5	HALF UNION, Q4M5	
1-1-5-2	S43682000	1	バルブハーネスX2クミ	VALVE HARNESS ASSY, X2	
1-1-5-2-1	S12404000	2	クロダバルブコネクタ	VALVE CONNECTOR	
1-1-6	062302506	2	ナベコ3X25	SCREW, PAN M3X25	
1-1-7	028030242	2	バネザガネ2-3	WASHER, SPRING 2-3	
1-1-8	025030232	2	ヒラザガネチユウ3	WASHER, PLAIN M 3	
1-1-9	S40629000	2	バレルニツブル	BARREL NIPPLE	
1-1-10	S23880000	2	エアーマフラー	AIR MUFFLER	
1-1-11	S43686000	1	PTエルボ1/4	ELBOW, PT 1/4	
			<コンプレッサー付仕様用>	<For with Compressor>	
1-2	S43694009	1	デンジバルブ2Bクミ	SOLENOID VALVE ASSY, 2B	
1-2-1	S31551009	1	バルブトリツケイタ2-3	VALVE SETTING PLATE, 2-3	
1-2-2	S09318101	1	インテグレータ	INTEGRATER	
1-2-3	S29710000	1	コネクタ6-1/4	CONNECTOR, 6-1/4	
1-2-4	S09228000	1	イケイニツブル	NIPPLE, 1/4X1/8	
1-2-5	S43679001	1	デンジバルブ2クミ	SOLENOID VALVE ASSY, 2	
1-2-5-1	S43680001	1	エアマニホルドクミ	AIR MANIFOLD ASSY	
1-2-5-1-1	S43684001	1	エアマニホルド	AIR MANIFOLD	
1-2-5-1-2	S43683001	2	デンジバルブ	SOLENOID VALVE	
1-2-5-1-3	S18415101	4	ハーフユニオンQ4M5	HALF UNION, Q4M5	
1-2-5-2	S43682000	1	バルブハーネスX2クミ	VALVE HARNESS ASSY, X2	
1-2-5-2-1	S12404000	2	クロダバルブコネクタ	VALVE CONNECTOR	
1-2-6	062302506	2	ナベコ3X25	SCREW, PAN M3X25	
1-2-7	028030242	2	バネザガネ2-3	WASHER, SPRING 2-3	
1-2-8	025030232	2	ヒラザガネチユウ3	WASHER, PLAIN M 3	
1-2-9	S23880000	2	エアーマフラー	AIR MUFFLER	
			<共通部品>	<Common parts>	
2	052501205	2	ナベコバネヒラ5X12	SCREW, PAN (S/P WASHER) M5X12	
5	021500103	2	ナツト1シユ5	NUT, 1 M5	
6	149796001	1	ゴムホースカナグツキ	AIR HOSE, W/CONNECTOR	
8-1	S43687001	1	ナイロンチューブR	AIR TUBE, N4-1A L = 1450	
8-2	S43687002	1	ナイロンチューブR	AIR TUBE, N4-1B L = 1450	
9-1	S43688001	1	ナイロンチューブL	AIR TUBE, N4-2A L = 1350	
9-2	S43688002	1	ナイロンチューブL	AIR TUBE, N4-2B L = 1350	
10	S12212000	1	スパイラル290S	SPIRAL, 290S	
29	S10243000	2	ナイロンクランプNK-3N	CORD HOLDER, NK-3N	
30	062400812	2	ナベコ4X8	SCREW, PAN M4X8	
31	228475000	2	ケツソクバンド1.9X80	FASTENING BAND, 1.9X80	
			<コンプレッサー付仕様用> <100V用>	<For with Compressor> <For 100V AC>	
12-1	S05670002	1	コンプレツサユニット	COMPRESSOR UNIT, 100V AC	
			<200V用>	<For 200V AC>	
12-1	S09393002	1	コンプレツサユニット	COMPRESSOR UNIT, 200V AC	

From the library of: Diamond Needle Corp

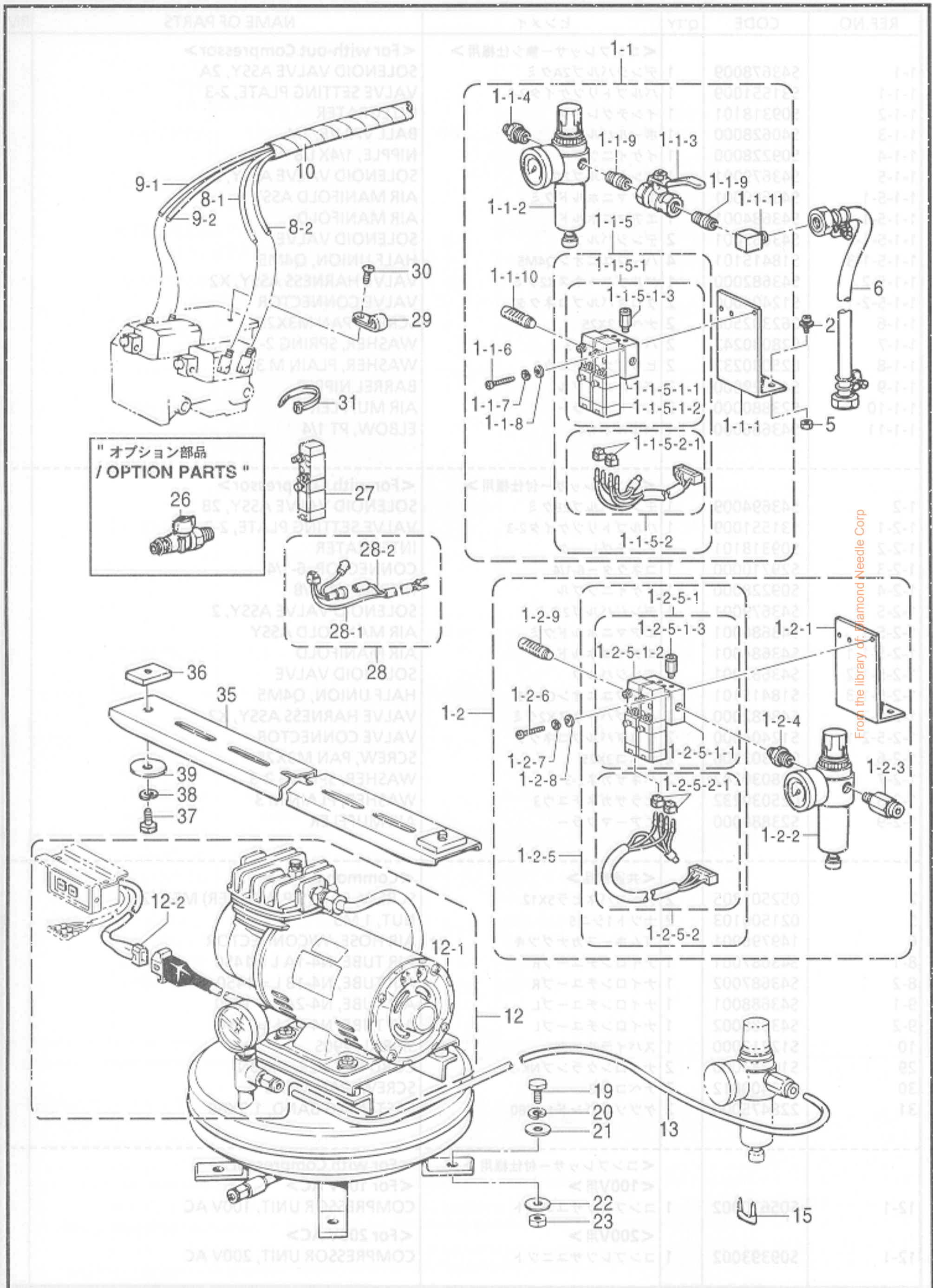

From the library of: Diamond Needle Corp

N. 空圧関係 / Air pressure mechanism / Luftdruck / Mécanisme de la pression d'air
/ Mecanismo de la presión de aire

REF.NO.	CODE	Q'TY	ヒンメイ	NAME OF PARTS	RM
13	S46255000	1	<コンプレッサー付仕様用> エアホース0604S688	<For with Compressor> AIR TUBE, 6 L = 680	
15	200190001	3	ステツブル	STAPLE	
19	017082203	4	ボルト8X22	BOLT, M8X22	
20	028080242	4	バネザガネ2-8	WASHER, SPRING 2-8	
21	025080232	4	ヒラザガネチユウ8	WASHER, PLAIN M 8	
22	025080336	4	ヒラザガネダイ8	WASHER, PLAIN L 8	
23	021080106	4	ナツト1シユ8	NUT, 1 M8	
35	S09224002	1	フミイタササエダイ	TREADLE SUPPORT BASE	
36	S09225001	2	4カクナツト	NUT, SQUARE	
37	017081606	2	ボルト8X16	BOLT, M8X16	
38	028080246	2	バネザガネ2-8	WASHER, SPRING 2-8	
39	S09226001	2	フミイタササエザガネ	WASHER	
26	S25100000	1	" オプション部品 " ボールバルブクミ	" OPTION PARTS " BALL VALVE ASSY	
27	S43683001	1	" 補給用部品 " デンジバルブ	" For Supply parts " SOLENOID VALVE	
28	S43696000	1	バルブハーネスX1	VALVE HARNESS, X1	
28-1	S44746000	1	ツイカバルブハーネス	VALVE HARNESS	
28-2	S44750000	1	ツイカバルブハーネス24V	VALVE HARNESS, 24V	
12	S50661009	1	<コンプレッサー付仕様用> <100V用> コンプレツサユニットクミ	" For with Compressor " <For 100V AC> COMPRESSOR UNIT ASSY, 100V AC	
12-1	S05670002	1	コンプレツサユニット	COMPRESSOR UNIT, 100V AC	
12-2	S43278000	1	コンプレツサーハーネス	COMPRESSOR HARNESS	
12	S50662009	1	<200V用> コンプレツサユニットクミ	<For 200V AC> COMPRESSOR UNIT ASSY, 200V AC	
12-1	S09393002	1	コンプレツサユニット	COMPRESSOR UNIT, 200V AC	
12-2	S43278000	1	コンプレツサーハーネス	COMPRESSOR HARNESS	

From the library of: Diamond Needle Corp

P. 電装品関係 / Power supply equipment mechanism / Stromversorgung

/ M canisme de l'«equipment en alimentation lectrique

/ Mecanismo del equipo de alimentaci n de corriente

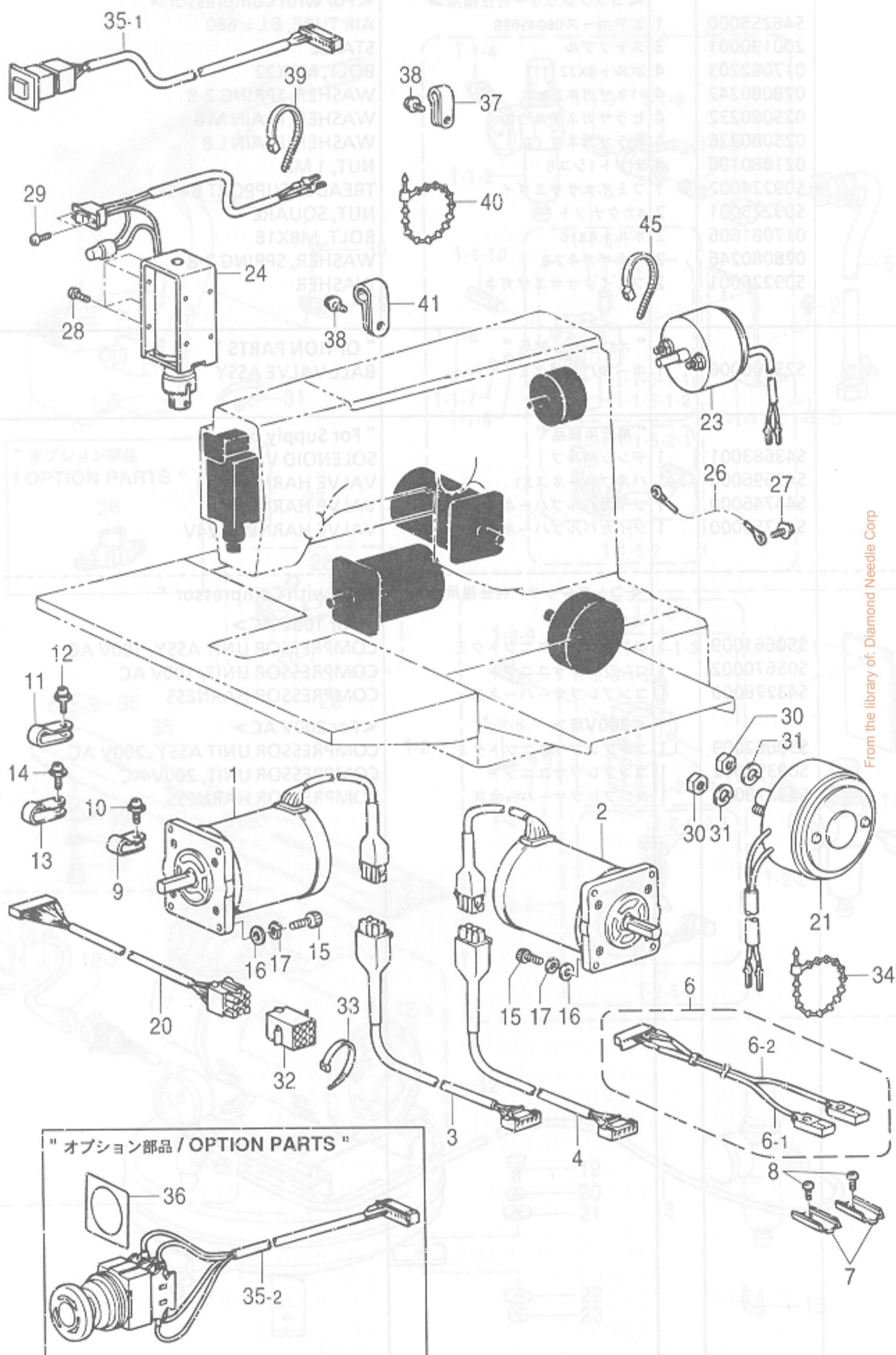

From the library of: Diamond Needle Corp

P. 電装品関係 / Power supply equipment mechanism / Stromversorgung
 / Mécanisme de l'équipement en alimentation électrique
 / Mecanismo del equipo de alimentación de corriente

REF.NO.	CODE	Q'TY	ヒンメイ	NAME OF PARTS	RM
1	S44383000	1	パルスモータXクミ	PULSE MOTOR ASSY, X	
2	S44372000	1	パルスモータYクミ	PULSE MOTOR ASSY, Y	
3	S43196000	1	パルスモータXハーネス	PULSE MOTOR HARNESS, X	
4	S43197000	1	パルスモータYハーネス	PULSE MOTOR HARNESS, Y	
6	S44664000	1	ゲンテンセンサハーネスクミ	SENSOR HARNESS ASSY, H/P	
6-1	S44665001	1	キンセツセンサGL-12F	PROXIMITY SENSOR, GL-12F	
6-2	S44665002	1	キンセツセンサGL-12F	PROXIMITY SENSOR, GL-12F	
7	S46476001	2	センサカナグ	SENSOR BRACKET	
8	002301203	2	+ナベコ3X12	SCREW, PAN M3X12	
9	S10243000	3	ナイロンクランプNK-3N	CORD HOLDER, NK-3N	
10	0A5401006	3	ナベコバネヒラ4X10	SCREW, PAN (S/P WASHER) M4X10	
11	525664000	1	コードホルダ#6	CORD HOLDER, 6N	
12	0A5401006	1	ナベコバネヒラ4X10	SCREW, PAN (S/P WASHER) M4X10	
13	149287000	3	ナイロンクランプ	CORD HOLDER, 7N	
14	0A5401006	3	ナベコバネヒラ4X10	SCREW, PAN (S/P WASHER) M4X10	
15	018501622	8	アナボルト5X16	BOLT, SOCKET M5X16	
16	025050232	8	ヒラザガネチユウ5	WASHER, PLAIN M 5	
17	028050242	8	バネザガネ2-5	WASHER, SPRING 2-5	
20	S43206000	1	ソレノイドハーネスクミ	SOLENOID HARNESS ASSY	
21	S43202000	1	カンケツソレノイドクミ	STEPPING SOLENOID ASSY	
23	S07818009	1	イトキリソレノイド	THREAD TRIMMER SOLENOID	
24	S41202051	1	イトハラソレノイドクミ	THREAD WIPER SOLENOID ASSY	
26	S38148000	1	アースセン1	GROUND WIRE, 1	
27	0A5401006	1	ナベコバネヒラ4X10	SCREW, PAN (S/P WASHER) M4X10	
28	062300612	4	ナベコ3X6	SCREW, PAN M3X6	
29	062300412	2	ナベコ3X4	SCREW, PAN M3X4	
30	021060206	2	2シユナツト6	NUT, 2 M6	
31	028060246	2	バネザガネ2-6	WASHER, SPRING 2-6	
32	S31674000	1	コネクタ3191-09P	CONNECTOR, 3191-09P	
33	149809000	1	タイラツプル	BEAD BAND, L = 200	
34	340400001	1	ユニタイバンド	BEAD BAND	
35-1	S43203000	1	EMスイッチクミ	EM-SWITCH ASSY	
37	525664000	3	コードホルダ#6	CORD HOLDER, 6N	
38	0A5401006	4	ナベコバネヒラ4X10	SCREW, PAN (S/P WASHER) M4X10	
39	228475000	2	ケツソクバンド1.9X80	FASTENING BAND, 1.9X80	
40	340400001	3	ユニタイバンド	BEAD BAND	
41	S00480000	1	コードホルダ#5	CORD HOLDER, 5N	
45	149809000	1	タイラツプル	BEAD BAND, L = 200	
35-2	S43204000	1	" オプション部品 "	" OPTION PARTS "	
36	S37057001	1	EMロックスイッチクミ	EM LOCK-SWITCH ASSY	
		1	EMスイッチスペーサ3	EM-SWITCH SPACER, 3	

From the library of: Diamond Needle Corp.

Q. 針位置検出器関係 / Synchronizer / Synchronisator / Synchronisateur / Sincronizador

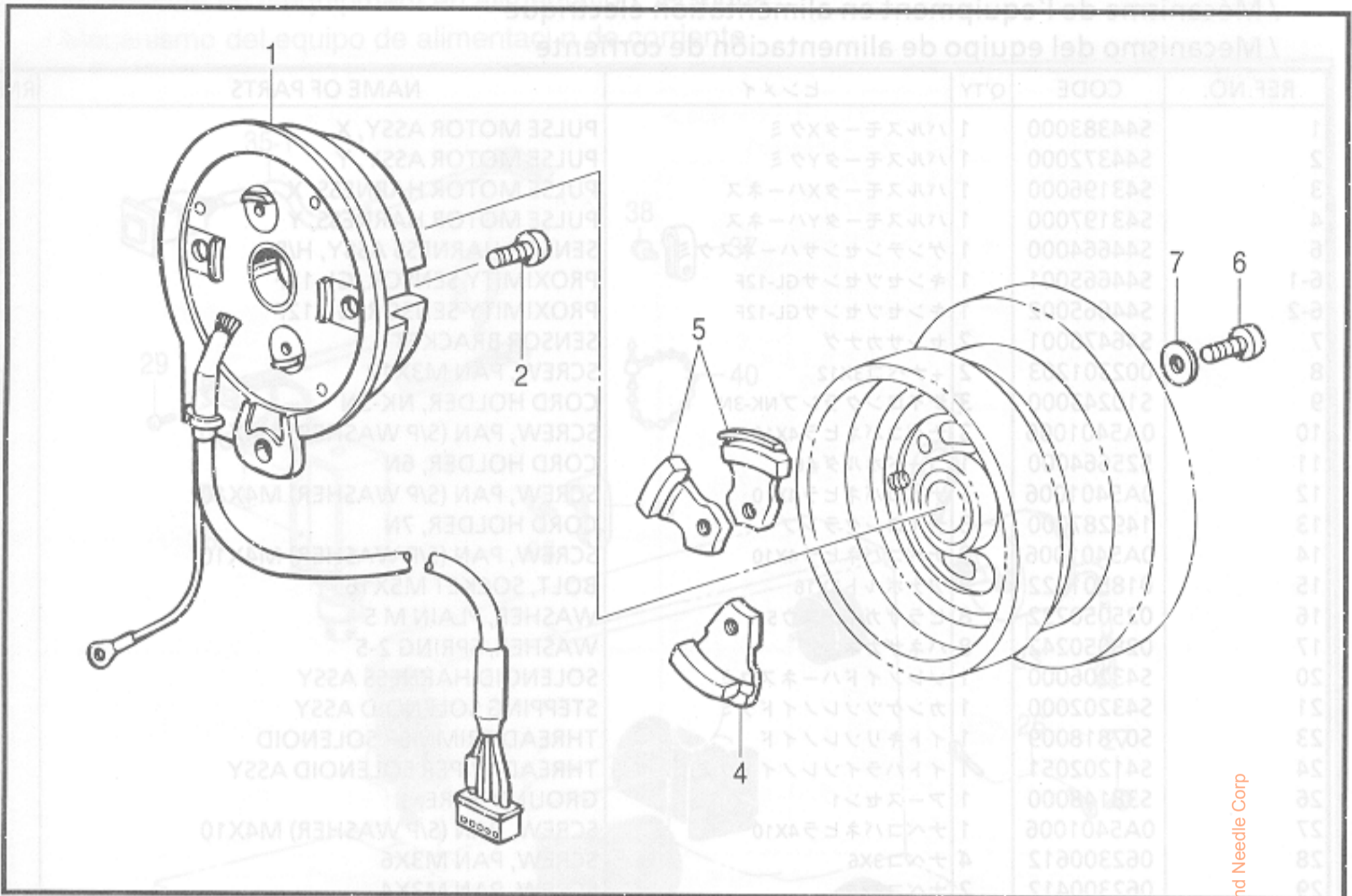

From the library of: Diamond Needle Corp

R. プリント基板関係 / Printed circuit board mechanism / Leiterplatten / Circuits imprimés / Tableros de circuitos impresos

151-V26-501

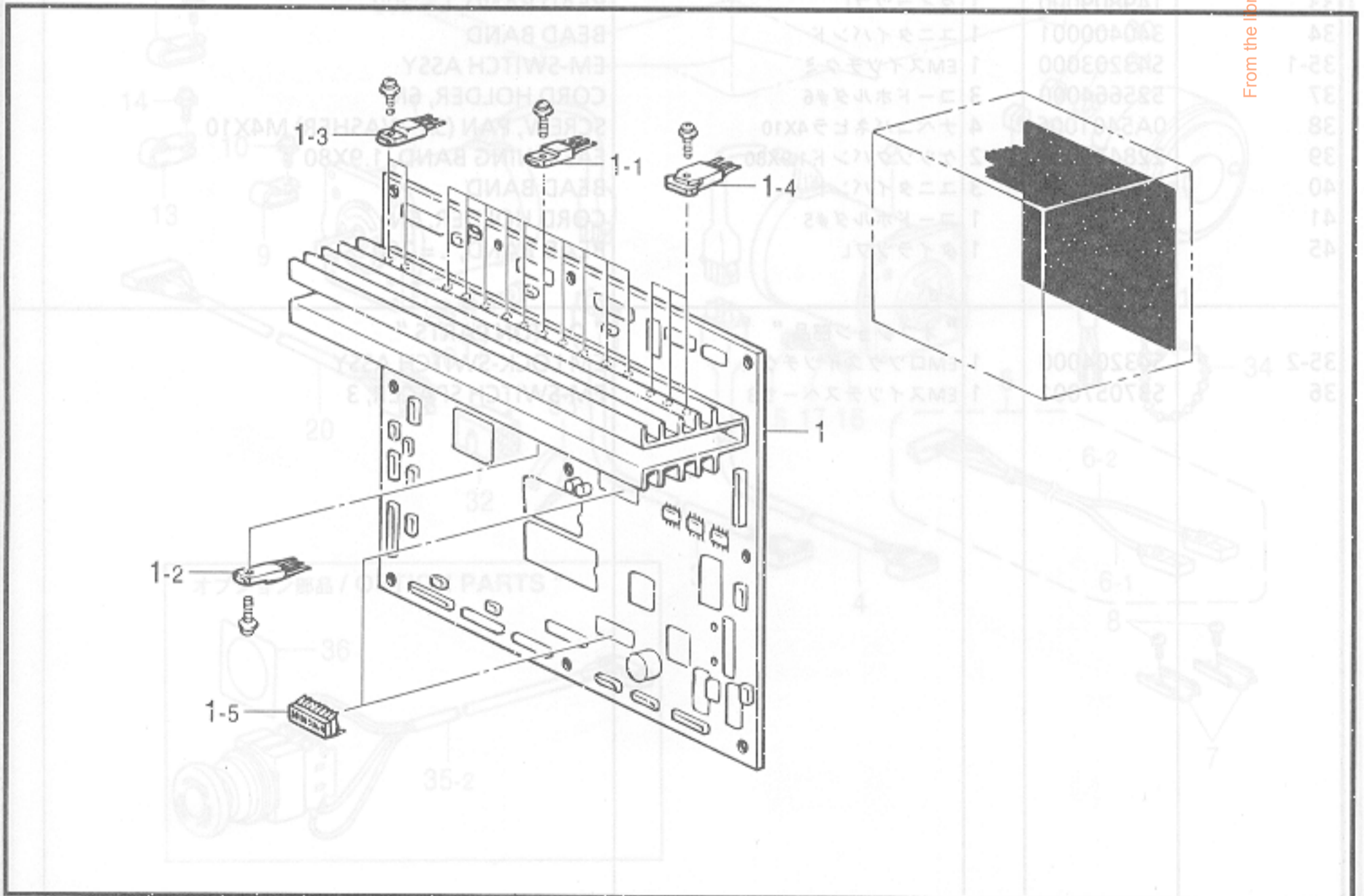

151-V26-518

Q. 針位置検出器関係 / Synchronizer / Synchronisator / Synchronisateur / Sincronizador

REF.NO.	CODE	Q'TY	ヒンメイ	NAME OF PARTS	RM
1	S48666001	1	シンクロナイザクミ	SYNCHRONIZER ASSY	
2	062400806	2	ナベコ4X8	SCREW, PAN M4X8	
4	S38080001	1	ハリシタジシヤククミ	MAGNET ASSY, D	
5	S38082001	2	ハリウエジシヤククミ	MAGNET ASSY, U	
6	062681412	3	ナベコ437-40X14	SCREW, PAN SM4.37-40X14	
7	025680132	3	ヒラザガネシヨウ4.37	WASHER, PLAIN S 4.37	
1-2-3	J34870001	1	DIPSWITCH	DIP SWITCH:K5P08	
1-2-4	S38104000	1	ENCODER	ENCODER, EVOVEMP01	
1-2-5	412387001	1	Buzzer	BUZZER:PKB245C 3601	
1-3	S43226000	1	FDD HARNESS	FDD HARNESS	
1-4	S43227000	1	PANEL HARNESS ASSY, P	PANEL HARNESS ASSY, P	
1-5	0A4300605	4	SCREW, PAN (S/P WASHER) M3X6	SCREW, PAN (S/P WASHER) M3X6	
1-6	064306605	4	SCREW, PAN (S/P WASHER) M3X6	SCREW, PAN (S/P WASHER) M3X6	
1-7	S43232000	1	PROM ASSY	PROM ASSY	
1-8	S02907000	1	DIAL	DIAL	
1-9	S43224000	1	SPACER	SPACER, P	
1-10	S43225000	2	FDD スプー	FDD SPOON	
1-11	0A4300605	4	SCREW, PAN (S/P WASHER) M3X6	SCREW, PAN (S/P WASHER) M3X6	
1-12	037300816	4	TAPPING SCREW, PAN V M3X8	TAPPING SCREW, PAN V M3X8	
1-13	S43228000	1	PROGRAMMER HARNESS ASSY, P	PROGRAMMER HARNESS ASSY, P	
1-14	002300603	2	SCREW, PAN M3X6	SCREW, PAN M3X6	
1-15	S42653000	1	CORE TFC-23-11-14	CORE TFC-23-11-14	
1-16	149809000	1	BEA BAND, L = 200	BEA BAND, L = 200	
1-17	008400604	1	SCREW, TRUSS M4X6	SCREW, TRUSS M4X6	
1-18	S36008009	1	SIDE COVER / PANEL	SIDE COVER / PANEL	
1-19	107321009	1	SHOULDER SCREW, SM4.76	SHOULDER SCREW, SM4.76	
1-20	107017001	1	WASHER, SPRING WAVE	WASHER, SPRING WAVE	

151-V26-501

R. プリント基板関係 / Printed circuit board mechanism / Leiterplatten / Circuits imprimés / Tableros de circuitos impresos

REF.NO.	CODE	Q'TY	ヒンメイ	NAME OF PARTS	RM
1	S43210001	1	セイギヨキバンクミ	CONTROL PCB ASSY	
1-1	U38337000	10	FET2SJ350	TRANSISTOR, FET:2SJ350	
1-2	U38338000	10	FET2SK2202	TRANSISTOR, FET:2SK2202	
1-3	S38155000	4	MOSFET2SK1306	TRANSISTOR, :2SK1306	
1-4	S38164000	6	MOSFET2SK1937	TRANSISTOR, :2SK1937	
1-5	U32744000	2	DIPSWDSS708	DIP SWITCH:DSS708	

From the library of Diamond Needle Corp

151-V26-518

S. 操作パネル関係 / Operation panel mechanism / Schaltkasten
 / M canisme du bo tier de contr le / Mecanismo del caja de controles

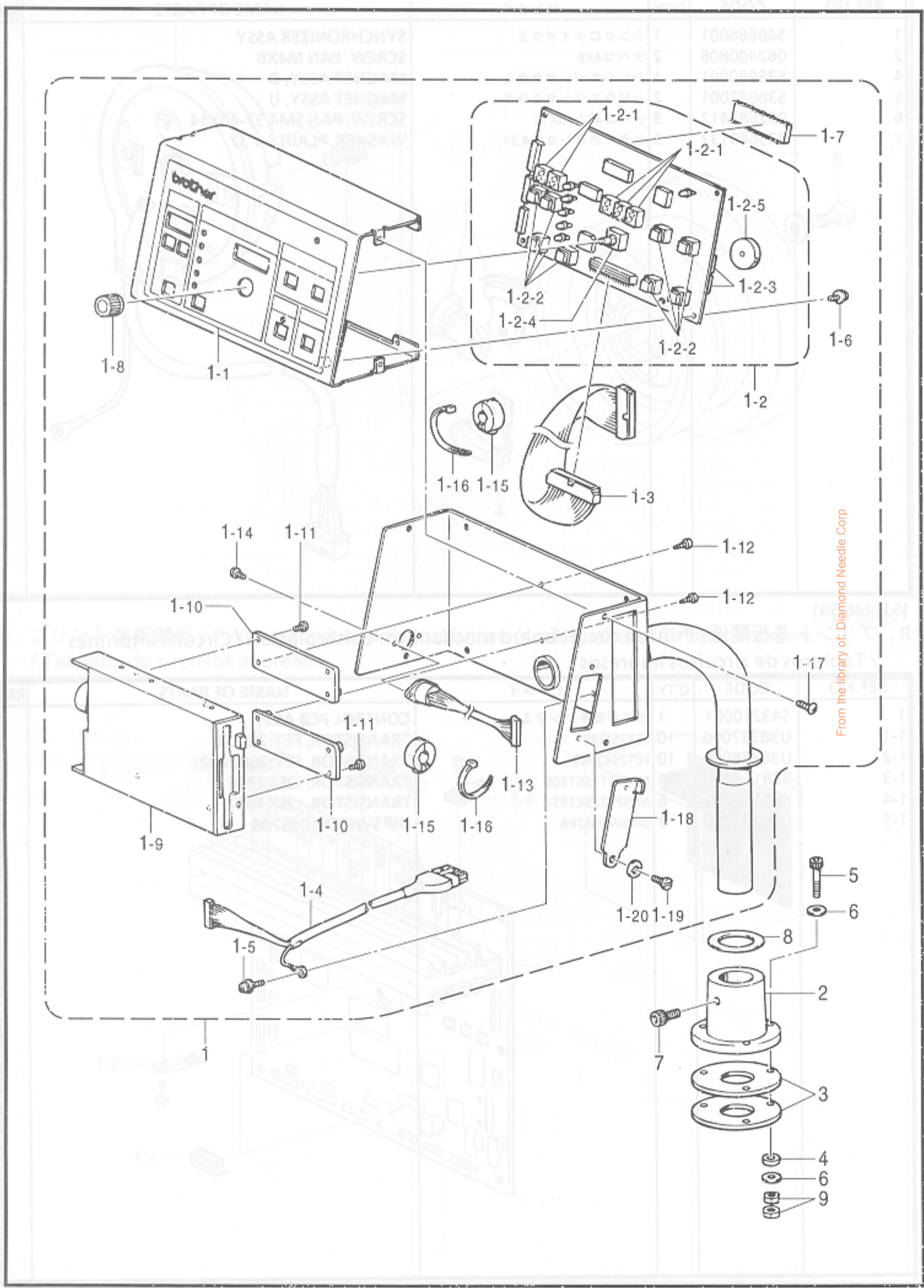

From the library of: Diamond Needle Corp

S. 操作パネル関係 / Operation panel mechanism / Schaltkasten
 / Mécanisme du boîtier de contrôle / Mecanismo del caja de controles

REF.NO.	CODE	Q'TY	ヒンメイ	NAME OF PARTS	RM
1	S43220209	1	ソウサパネルクミ	OPERATION PANEL ASSY	
1-1	S43223009	1	ソウサパネルフィルム	FILM, OPERATION PANEL	
1-2	S43229001	1	パネルキバンクミ	PANEL PCB ASSY	
1-2-1	S29023000	5	LEDGL9P040	LED, GL9P040	
1-2-2	S30260002	8	SWDP1-100	SWITCH, DP1-100 ;GRAY	
1-2-3	U34870001	2	DIPSW KSP08	DIP SWITCH:KSP08	
1-2-4	S38104000	1	エンコーダEVQVEMF01	ENCODER, EVQVEMF01	
1-2-5	417382001	1	PKB24SC-3601	BUZZER:PKB24SC-3601	
1-3	S43226000	1	FDDハーネス	FDD HARNESS	
1-4	S43227200	1	パネルコードPクミ	PANEL HARNESS ASSY, P	
1-5	0A5400805	1	+ナベザクミ4X8DB	SCREW, PAN (S/P WASHER) M4X8	
1-6	0A4300605	4	+ナベザクミ3X6DA	SCREW, PAN (S/P WASHER) M3X6	
1-7	S43237000	1	PROMパネルクミ	PROM ASSY, PANEL	
1-8	S02907000	1	ツマミ	DIAL	
1-9	S43224000	1	3.5FDD	FDD, 3.5	
1-10	S43225000	2	FDDスパーサ	SPACER, FDD	
1-11	0A4300605	4	+ナベザクミ3X6DA	SCREW, PAN (S/P WASHER) M3X6	
1-12	037300816	4	Vナベタツピン3X8	TAPPING SCREW, PAN V M3X8	
1-13	S43228000	1	プログラマコードPクミ	PROGRAMMER HARNESS ASSY, P	
1-14	002300603	2	+ナベコ3X6	SCREW, PAN M3X6	
1-15	S42653000	2	コアTFC-23-11-14	CORE, TFC-23-11-14	
1-16	149809000	2	タイラツプル	BEAD BAND, L = 200	
1-17	008400604	8	+トラスコ4X6	SCREW, TRUSS M4X6	
1-18	S36008009	1	パネルヨコカバー	SIDE COVER, PANEL	
1-19	107321009	1	ダンネジ4.76	SHOULDER SCREW, SM4.76	
1-20	107017001	1	ナミバネザガネ	WASHER, SPRING WAVE	
2	S43236009	1	ソウサパネルドダイ	OPERATION PANEL BASE	
3	S43674000	2	クツシヨンA	CUSHION, A	
4	S43675000	3	クツシヨンB	CUSHION, B	
5	S25634101	3	アナボルト5X65	BOLT, SOCKET M5X65	
6	025050236	6	ヒラザガネチユウ5	WASHER, PLAIN M 5	
7	018081636	1	アナボルト8X16	BOLT, SOCKET M8X16	
8	S10408000	1	ゴムシート	RUBBER SHEET	
9	021500106	6	1シユナツト5	NUT, 1 M5	
5-1	44806000	1	ペダルフットSWハーネス	PEDAL FOOT SW HARNESS ASSY	
5-2	36220000	3	ペダルフットSWハーネス	PEDAL FOOT SW HARNESS	
6	633012005	1	スクリューM3X12	SCREW, PAN M3X12	
7	94750000	1	ステンリング1.9X80	STAINING RING, 1.9X80	
8	122740000	1	フットペダル	FOOT PEDAL	
9	381750001	1	ペダル保護プレート	PEDAL PROTECTION PLATE	
10	381761001	1	スプリングベース	SPRING BASE	
11	022000403	6	スクリューM3X4	SCREW, PAN M3X4	
12	022000403	6	ワッシャーM3X4	WASHER, PLAIN M3X4	
13	025030236	6	ワッシャーM5	WASHER, PLAIN M5	
14	381750001	3	フットペダルシャフト	FOOT PEDAL SHAFT	
15	48050346	5	スクリューM5	SCREW, PAN M5	
16	022000403	2	スクリューM3X4	SCREW, PAN (S/P)WASHER M3X4	
17	017936001	14	ゴムキャップ	RUBBER CAP, 9.4	
18	017800000	1	コネクタ172160-1	CONNECTOR, 172160-1	
19	038050000	1	コネクタ18X19	CONNECTOR, 18X19	
20	038059000	3	ゴムキャップNG79F	RUBBER CAP, NG79F	
	09443000	1	コネクタ170364-1	CONNECTOR, 170364-1	

From the library of: Diamond Needle Corp

T. 踏板関係 / Foot switch pedal mechanism / Fußbet tigung / M carisme de la p dale
 / Mecanismo del pedal

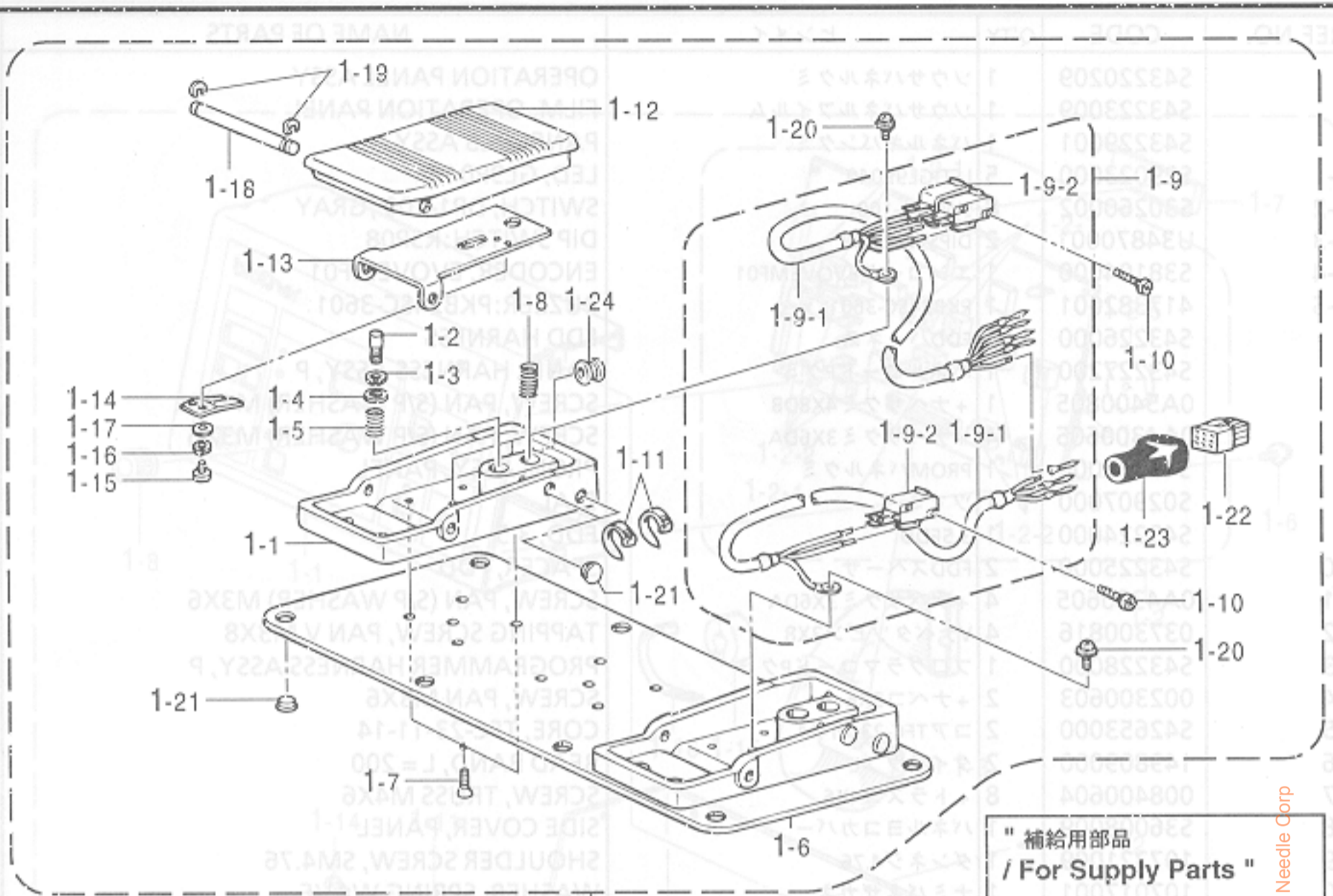

" 補給用部品
 / For Supply Parts "

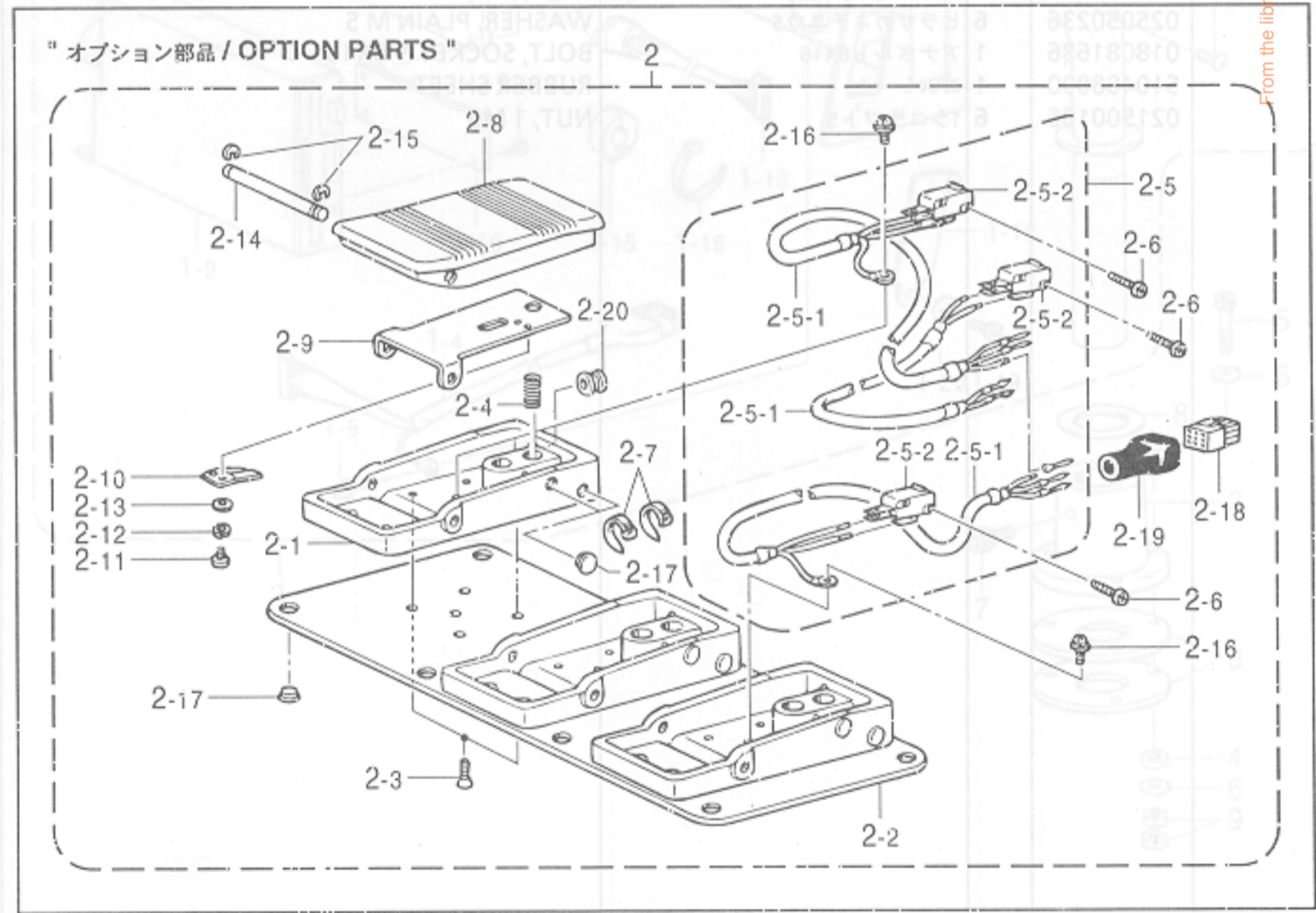

From the library of: Diamond Needle Corp

T. 踏板関係 / Foot switch pedal mechanism / Fußbetätigung / Mécanisme de la pédale / Mecanismo del pedal

REF.NO.	CODE	Q'TY	ヒンメイ	NAME OF PARTS	RM
1	S42842101	1	2レンフット3SW	2-PEDAL FOOT SWITCH, 3	
1-1	S38166000	2	フットペダルダイ	FOOT PEDAL BASE	
1-2	S38167001	1	2ダンSWピン	SWITCH PIN, 2-STEP	
1-3	048060142	1	トメワジクヨウC6	RETAINING RING, EXTERNAL C6	
1-4	025060236	1	ヒラザガネチユウ6	WASHER, PLAIN M 6	
1-5	S38168001	1	アツシユクバネ	SPRING, COMPRESSION	
1-6	S42867001	1	フミイタホジヨイタ	TREADLE AUXILIARY PLATE	
1-7	004400603	4	+サラコネジ4X6	SCREW, FLAT M4X6	
1-8	S38170001	2	フットペダルバネ	SPRING, COMPRESSION	
1-9	S42259000	1	2レンフット3SWハーネスクミ	2-PEDAL FOOT SW HARNESS ASSY, 3	
1-9-1	S42258000	1	2レンフット3SWハーネス	2-PEDAL FOOT SW HARNESS, 3	
1-9-2	S36260000	3	スイッチVXピンボタン	SWITCH PIN BUTTON, VX	
1-10	062301205	4	ナベコ3X12	SCREW, PAN M3X12	
1-11	228475000	10	ケツソクバンド1.9X80	FASTENING BAND, 1.9X80	
1-12	S38174000	2	フットペダル	FOOT PEDAL	
1-13	S38175001	2	ペダルホゴイタ	PEDAL PROTECTION PLATE	
1-14	S38176101	2	スイッチオサエバネ	SPRING, PLATE	
1-15	002300403	4	+ナベコ3X4	SCREW, PAN M3X4	
1-16	028030246	4	バネザガネ2-3	WASHER, SPRING 2-3	
1-17	025030236	4	ヒラザガネチユウ3	WASHER, PLAIN M 3	
1-18	S38177001	2	フットペダルジク	FOOT PEDAL SHAFT	
1-19	048050346	4	トメワE5	RETAINING RING, E5	
1-20	052400606	2	ナベコバネヒラ4X6	SCREW, PAN (S/P WASHER) M4X6	
1-21	117936001	12	ゴムセン9.4	RUBBER CAP, 9.4	
1-22	S38180000	1	コネクタ172169-1	CONNECTOR, 172169-1	
1-23	S38060000	1	コネクタキヤツブ18X19	CONNECTOR CAP, 18X19	
1-24	S38059000	2	グロメットNG79F	RUBBER CAP, NG79F	
2	S44805101	1	" オプション部品 "	" OPTION PARTS "	
2-1	S38166000	3	3レンフット3SW	3-PEDAL FOOT SWITCH, 3	
2-2	S42867001	1	フットペダルダイ	FOOT PEDAL BASE	
2-3	004400603	6	フミイタホジヨイタ	TREADLE AUXILIARY PLATE	
2-4	S38170001	3	+サラコネジ4X6	SCREW, FLAT M4X6	
2-5	S44806000	1	フットペダルバネ	SPRING, COMPRESSION	
2-5-1	S44807000	1	3レンフットSWハーネスクミ	3-PEDAL FOOT SW HARNESS ASSY	
2-5-2	S36260000	1	3レンフットSWハーネス	3-PEDAL FOOT SW HARNESS	
2-6	S36260000	3	スイッチVXピンボタン	SWITCH PIN BUTTON, VX	
2-6	062301205	6	ナベコ3X12	SCREW, PAN M3X12	
2-7	228475000	10	ケツソクバンド1.9X80	FASTENING BAND, 1.9X80	
2-8	S38174000	3	フットペダル	FOOT PEDAL	
2-9	S38175001	3	ペダルホゴイタ	PEDAL PROTECTION PLATE	
2-10	S38176101	3	スイッチオサエバネ	SPRING, PLATE	
2-11	002300403	6	+ナベコ3X4	SCREW, PAN M3X4	
2-12	028030246	6	バネザガネ2-3	WASHER, SPRING 2-3	
2-13	025030236	6	ヒラザガネチユウ3	WASHER, PLAIN M 3	
2-14	S38177001	3	フットペダルジク	FOOT PEDAL SHAFT	
2-15	048050346	6	トメワE5	RETAINING RING, E5	
2-16	052400606	2	ナベコバネヒラ4X6	SCREW, PAN (S/P WASHER) M4X6	
2-17	117936001	14	ゴムセン9.4	RUBBER CAP, 9.4	
2-18	S38180000	1	コネクタ172169-1	CONNECTOR, 172169-1	
2-19	S38060000	1	コネクタキヤツブ18X19	CONNECTOR CAP, 18X19	
2-20	S38059000	3	グロメットNG79F	RUBBER CAP, NG79F	
3	S49443000	1	" 補給用部品 "	" For Supply parts "	
			コネクタ170364-1	CONNECTOR, 170364-1	

From the library of: Diamond Needle Corp

U1 . 動力台関係 (国内用) / Power table (For Japan only) / Motorgestell
 / Mécanisme du plateau de la machine / Mecanismo de la mesa de la máquina

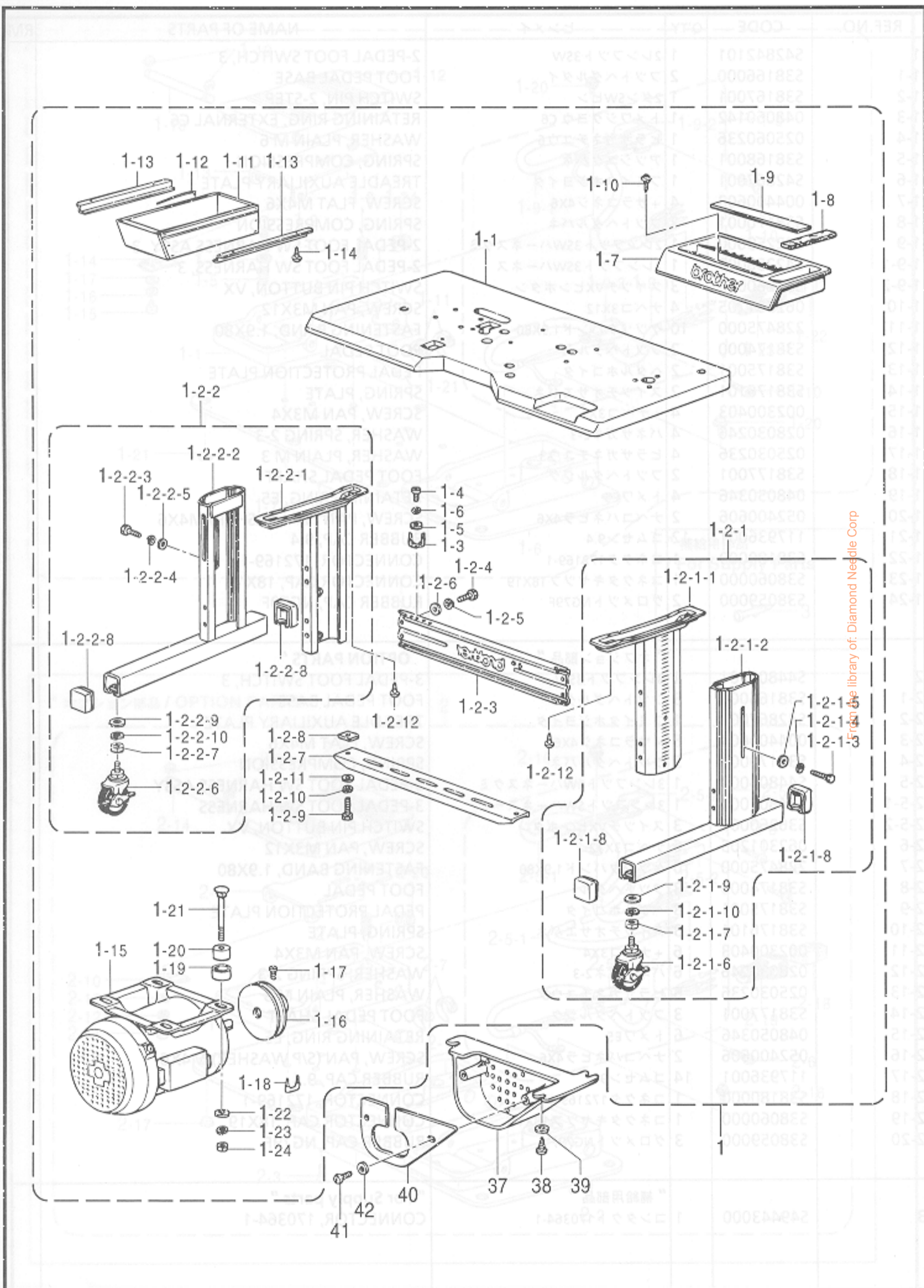

From the library of: Diamond Needle Corp

U1. 動力台関係 (国内用) / Power table (For only Japan) / Motorgestell
 / Mécanisme du plateau de la machine / Mecanismo de la mesa de la máquina

REF.NO.	CODE	Q'TY	ヒンメイ	NAME OF PARTS	RM
26	S46460000		<国内用標準テーブル>	<For only Japan> 200V AC-400W	
1	S42850409	1	311テーブルキヤククミ	
1-1	S42851301	1	311テーブル	
1-2	S43671109	1	タチヨウキヤククミ	
1-2-1	S09639009	1	タチキヤクRクミ	
1-2-1-1	S09216002	1	テーブルササエR	
1-2-1-2	S09217102	1	ソトアシR	
1-2-1-3	017081606	3	ボルト8X16	
1-2-1-4	028080246	3	バネザガネ2-8	
1-2-1-5	S09312001	3	ヒラザガネダイ8	
1-2-1-6	S05223001	2	キヤスター	
1-2-1-7	022120306	2	ナツト3シユ12	
1-2-1-8	S10661109	2	ソトアシフタゴム	
1-2-1-9	026120236	2	ヒラザガネミガキ12	
1-2-1-10	028120246	2	バネザガネ2-12	
1-2-2	S09640009	1	タチキヤクLクミ	
1-2-2-1	S09221002	1	テーブルササエL	
1-2-2-2	S09222102	1	ソトアシL	
1-2-2-3	017081606	3	ボルト8X16	
1-2-2-4	028080246	3	バネザガネ2-8	
1-2-2-5	S09312001	3	ヒラザガネダイ8	
1-2-2-6	S05223001	2	キヤスター	
1-2-2-7	022120306	2	ナツト3シユ12	
1-2-2-8	S10661109	2	ソトアシフタゴム	
1-2-2-9	026120236	2	ヒラザガネミガキ12	
1-2-2-10	028120246	2	バネザガネ2-12	
1-2-3	S43672109	1	ハリ	
1-2-4	017081606	4	ボルト8X16	
1-2-5	028080246	4	バネザガネ2-8	
1-2-6	025080236	4	ヒラザガネチユウ8	
1-2-7	S09224002	1	フミイタササエダイ	
1-2-8	S09225001	2	4カクナツト	
1-2-9	017081606	2	ボルト8X16	
1-2-10	028080246	2	バネザガネ2-8	
1-2-11	S09226001	2	フミイタササエザガネ	
1-2-12	133180005	4	+マルモクネジ6.2X38	
1-3	133172003	1	アブラサシダイ	
1-4	037521016	1	+ナベタツピン2シユ5	
1-5	025050236	1	ヒラザガネチユウ5	
1-6	028050246	1	バネザガネ2-5	
1-7	S15158009	1	コモノケース	
1-8	S02740000	1	フェルト	
1-9	S02739000	1	ゴムジシヤクテープ	
1-10	039411215	2	1トラスタツピン4X12	
1-11	119702004	1	ヨコヒキダシ	
1-12	101073001	1	ヒキダシコテイバネ	
1-13	101121000	2	ヨコヒキダシササエ	
1-14	032361306	4	+マルモクネジ3.5X13	
1-15	S46460000	1	3ソウ400Wモータ200V	
1-16	S38041000	1	モータブーリ	
1-17	105073001	1	アタマツキトメネジ5.95	
1-18	200190001	5	ステツブル	
1-19	146256001	4	クツシヨンカナグ	
1-20	146255000	4	クツシヨン	
1-21	133740006	4	カクネボルト6X70	
1-22	025060336	4	ヒラザガネダイ6	
1-23	028060246	4	バネザガネ2-6	
1-24	021060106	4	1シユナツト6	
37	S18633109	1	モータカバー	
38	032422003	3	+マルモクネジ4.1X20	
39	116662003	3	ザガネ	
40	S20137001	1	モーターウシロカバー	
41	138444001	2	ナベBタイト4X14	
42	025040232	2	ヒラザガネチユウ4	

From the library of: Diamond Needle Corp

U2 . 動力台関係 (輸出用) / Power table (For Export) / Motorgestell
 / M canisme du plateau de la machine / Mecanismo de la mesa de la mquina

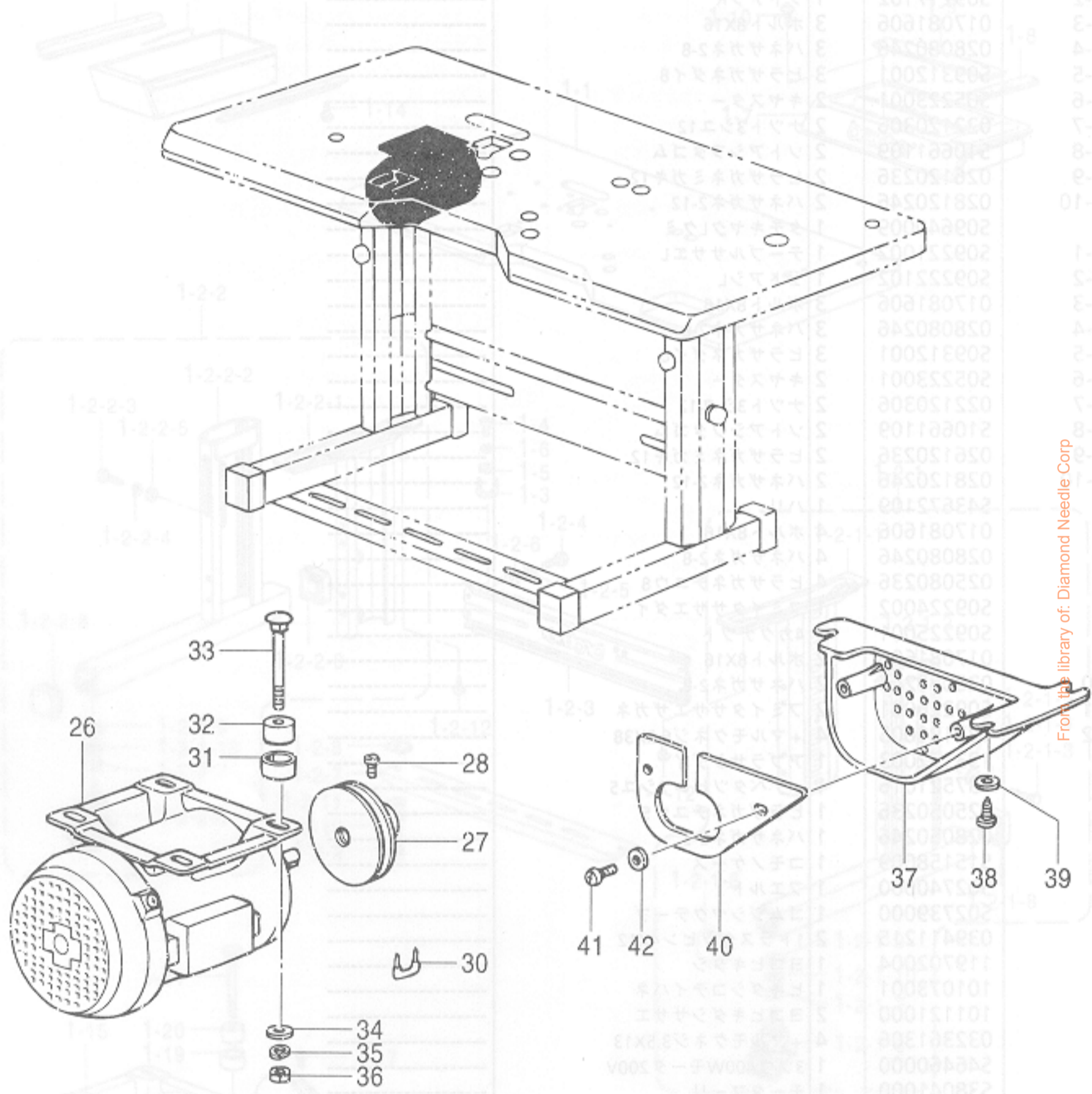

From the library of: Diamond Needle Corp

U2 . 動力台関係 (輸出用) / Power table (For Export) / Motorgestell
 / Mécanisme du plateau de la machine / Mecanismo de la mesa de la máquina

REF.NO.	CODE	Q'TY	ヒンメイ	NAME OF PARTS	RM
26	S46460000	1	3ソウ400Wモータ200V	MOTOR, 3-PHASE 200V AC-400W	
27	S38041000	1	モータプーリ	MOTOR PULLEY	
28	105073001	1	アタマツキトメネジ5.95	SET SCREW, SM5.95	
30	200190001	5	ステツフル	STAPLE	
31	146256001	4	クツシヨンカナグ	CUSHION COLLAR	
32	146255000	4	クツシヨン	CUSHION	
33	133740006	4	カクネボルト6X70	BOLT, M6X70	
34	025060336	4	ヒラザガネダイ6	WASHER, PLAIN L 6	
35	028060246	4	バネザガネ2-6	WASHER, SPRING 2-6	
36	021060106	4	1シユナツト6	NUT, 1 M6	
37	S18633109	1	モータカバー	MOTOR COVER	
38	032422003	3	+マルモクネジ4.1X20	WOOD SCREW, ROUND M4.1X20	
39	116662003	3	ザガネ	WASHER	
40	S20137001	1	モーターウシロカバー	BACK COVER, MOTOR	
41	138444001	2	ナベBタイト4X14	TAPTITE, PAN B M4X14	
42	025040232	2	ヒラザガネチユウ4	WASHER, PLAIN M 4	
1-1	S20293101		ワークホルダー	WORK CLAMP	*
1-2	018680822		ボルト	BOLT, SOCKET	*
1-1	S44415000		ワンタッチホルダー	ONE-TOUCH HOLDER	*
1-2	S44417000		ワンタッチホルダー	ONE-TOUCH HOLDER	*

From the library of: Diamond Needle Corp

51-V26-941

RM欄に*が付いている部品は、精密に調整されていますので絶対に分解しないで下さい。
 Parts which have an asterisk (*) in the RM column are parts which have been assembled and adjusted to high precision. These parts should never be disassembled.
 Die in der Kolonne RM mit einem Asteriskus (*) bezeichneten Teile sind mit hoher Präzision zusammengebaut und eingestellt worden. Aus diesem Grunde dürfen diese Teile niemals zerlegt werden.
 Les pièces désignées par un astérisque (*) dans la colonne RM sont des pièces qui ont été assemblées et réglées avec une grande précision. Il ne faut en aucun cas décomposer ces pièces.
 Las partes que tienen un asterisco (*) en la columna RM son las partes que han sido armadas y ajustadas a alta precisión.

V. ワンタッチ押工装置関係 (オプション部品) / One-touch work clamp (Option parts)
 / One-Touch-Stoffhalterheber (Sonderzubehor) / Pinceur simple touche (Pi ces en option)
 / Prensor de un toque (Piezas opcionales)

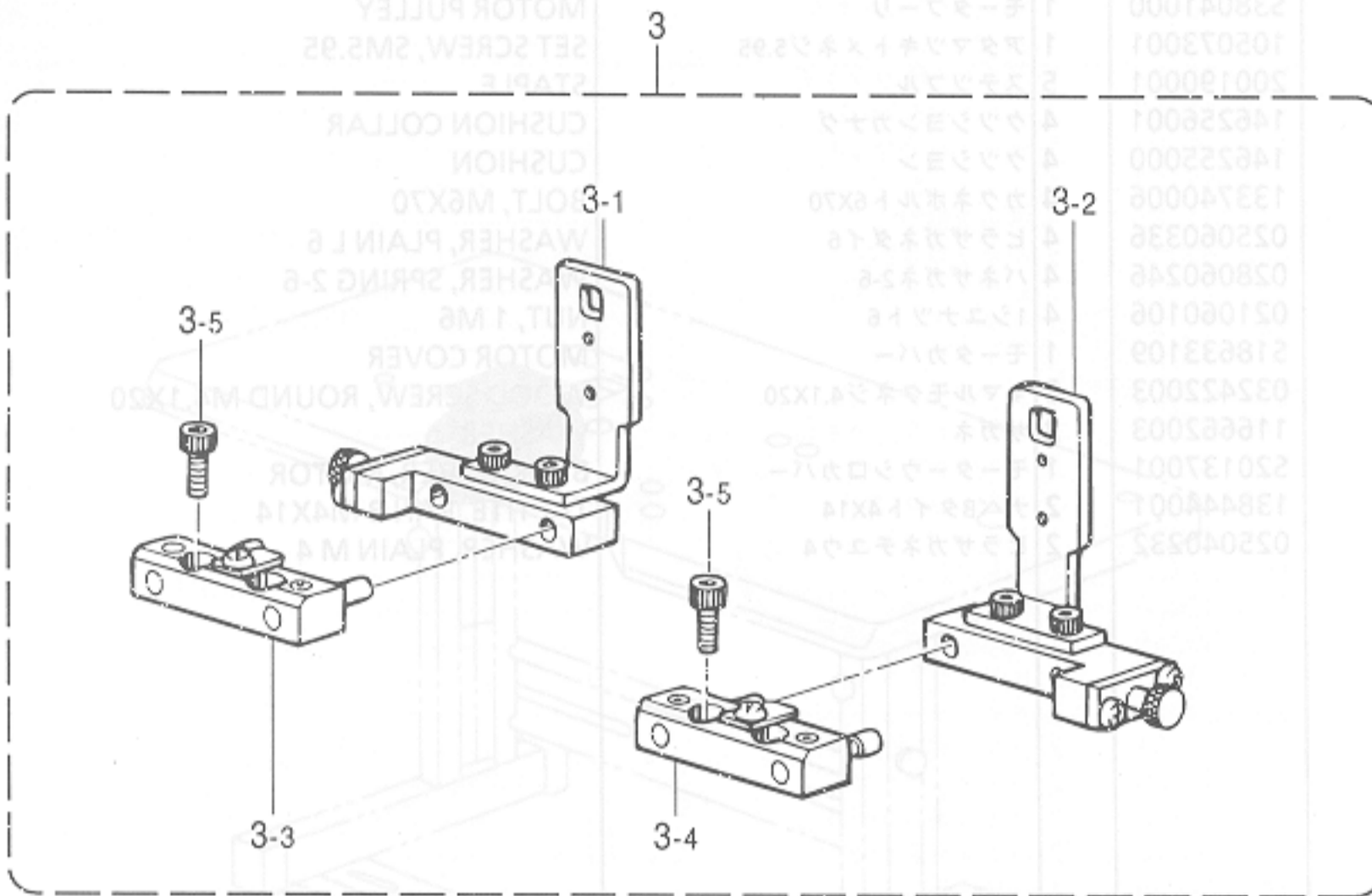

" 補給用部品 / For Supply parts "

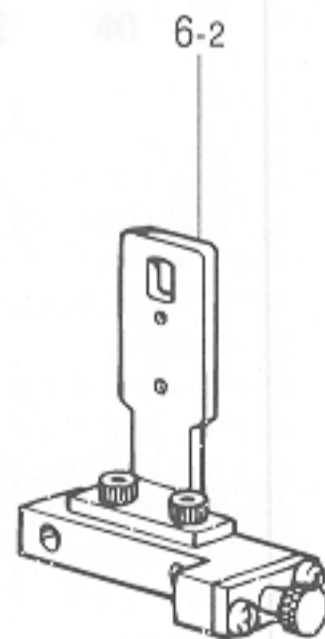
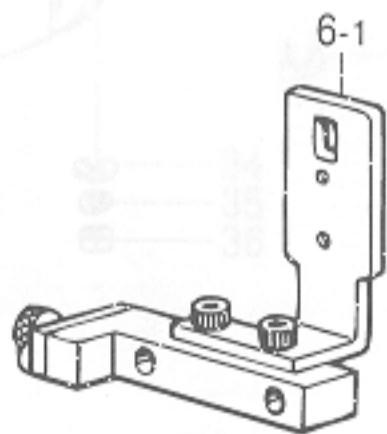
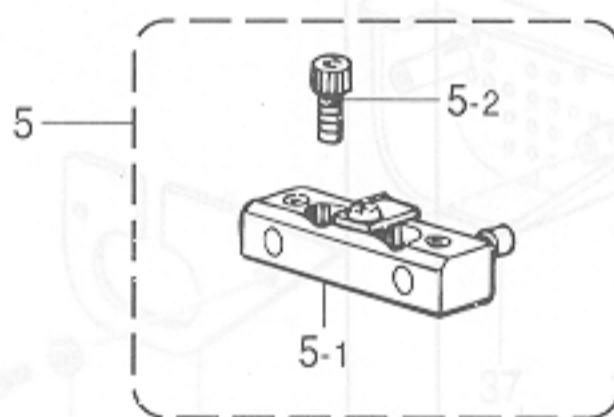
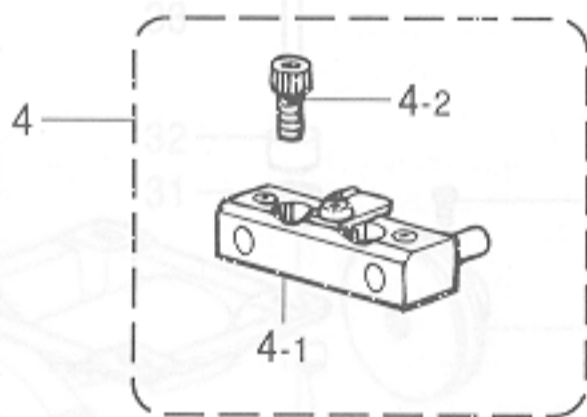

From the library of: Diamond Needle Corp

V. ワンタッチ押工装置関係 (オプション部品) / Thread wiper set (Option parts)
 / Fadenspannvorrichtung (Sonderzubehör) / Mécanisme de tire-fil (Pièces en option)
 / Mecanismo del limpiador de hilo (Piezas opcionales)

REF.NO.	CODE	Q'TY	ヒンメイ	NAME OF PARTS	RM
3	S44414001	1	<ワンタッチ押工装置> ワンタッチオサエソウチセット	<One-touch work clamp set> ONE-TOUCH WORK CLAMP SET, 326E	※
3-1	S44415001	1	ワンタッチオサエLクミ	ONE-TOUCH HOLDER ASSY, L	※
3-2	S44417001	1	ワンタッチオサエRクミ	ONE-TOUCH HOLDER ASSY, R	※
3-3	S20289101	2	ジクホルダーLクミ	WORK CLAMP HOLDER ASSY, L	※
3-4	S20293101	2	ジクホルダーRクミ	WORK CLAMP HOLDER ASSY, R	※
3-5	018680822	8	アナボルト4.37X8	BOLT, SOCKET SM4.37X8	※
4	S20822101	1	" 補給用部品 " ジクホルダーLセット	" For Supply parts " WORK CLAMP HOLDER SET, L	※
4-1	S20289101	1	ジクホルダーLクミ	WORK CLAMP HOLDER ASSY, L	※
4-2	018680822	2	アナボルト4.37X8	BOLT, SOCKET SM4.37X8	※
5	S20823101	1	ジクホルダーRセット	WORK CLAMP HOLDER SET, R	※
5-1	S20293101	1	ジクホルダーRクミ	WORK CLAMP HOLDER ASSY, R	※
5-2	018680822	2	アナボルト4.37X8	BOLT, SOCKET SM4.37X8	※
6-1	S44415001	1	ワンタッチオサエLクミ	ONE-TOUCH HOLDER ASSY, L	※
6-2	S44417001	1	ワンタッチオサエRクミ	ONE-TOUCH HOLDER ASSY, R	※
" OPTION PARTS "					
2	S40621000	1	EMIコアESD-SR-15	EMI CORE, ESD-SR-15	
3	149809000	1	タイラップ	BEAD BAND, L=200	

From the library of: Diamond Needle Corp

151-V26-941

- ☆ RM欄に※が付いている部品は、精密な組立て調整がして有りますので絶対に分解しないで下さい。
- ☆ Parts which have an asterisk (※) in the RM column are parts which have been assembled and adjusted to high precisions. These parts should never be disassembled.
- ☆ Die in der Kolonne RM mit einem Asteriskus (※) bezeichneten Teile sind mit hoher präzision zusammengebaut und eigestellt worden. Aus diesem Grunde dürfen diese Teile niemals zerlegt werden.
- ☆ Les pièces désignées par un astérisque (※) dans la colonne RM sont des pièces qui ont été assemblées et réglées avec une grande précision. Il ne faut en aucun cas déposer ces pièces.
- ☆ Las partes que tienen un asterisco (※) en la columna RM son las partes que han sido armadas y ajustadas a alta precisión. Estas partes nunca deberán ser desarmadas.

W. プログラマー関係 (オプション部品) / Programmer (Option parts) / Programmiervorrichtung (Sonderzubeh r)
 / Programmeur (Pi ces en option) / Programador (Piezas opcionales)

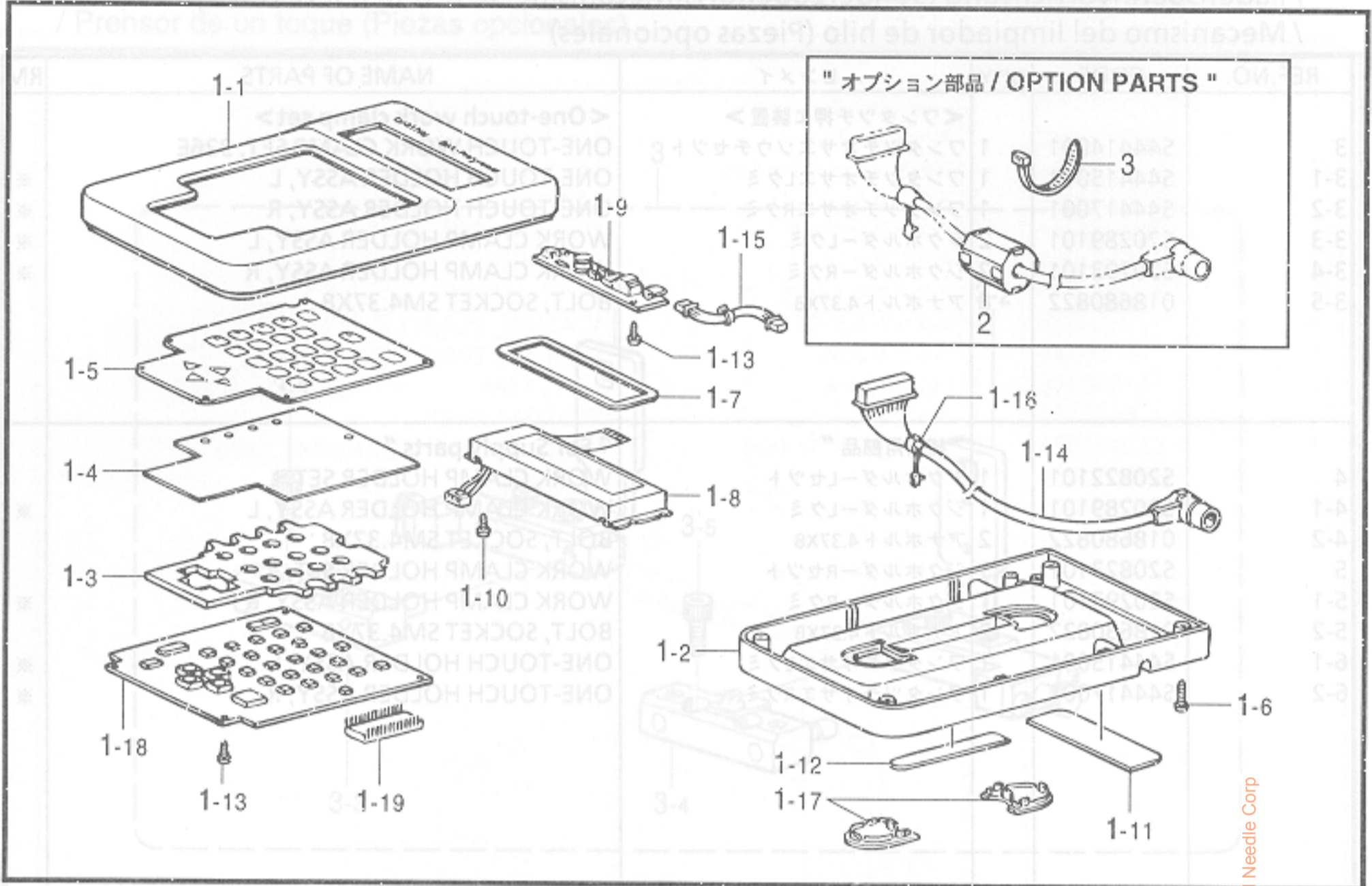

151-V26-942

X. ワイドパーフェクト装置関係 (オプション部品) / Wide perfect device (Option parts)
 / Wide-perfect-Vorrichtung (Sonderzubeh r) / Dispositifs de perfection large (Pi ces en option)
 / Dispositivo de ancho pfecto (Piezas opcionales)

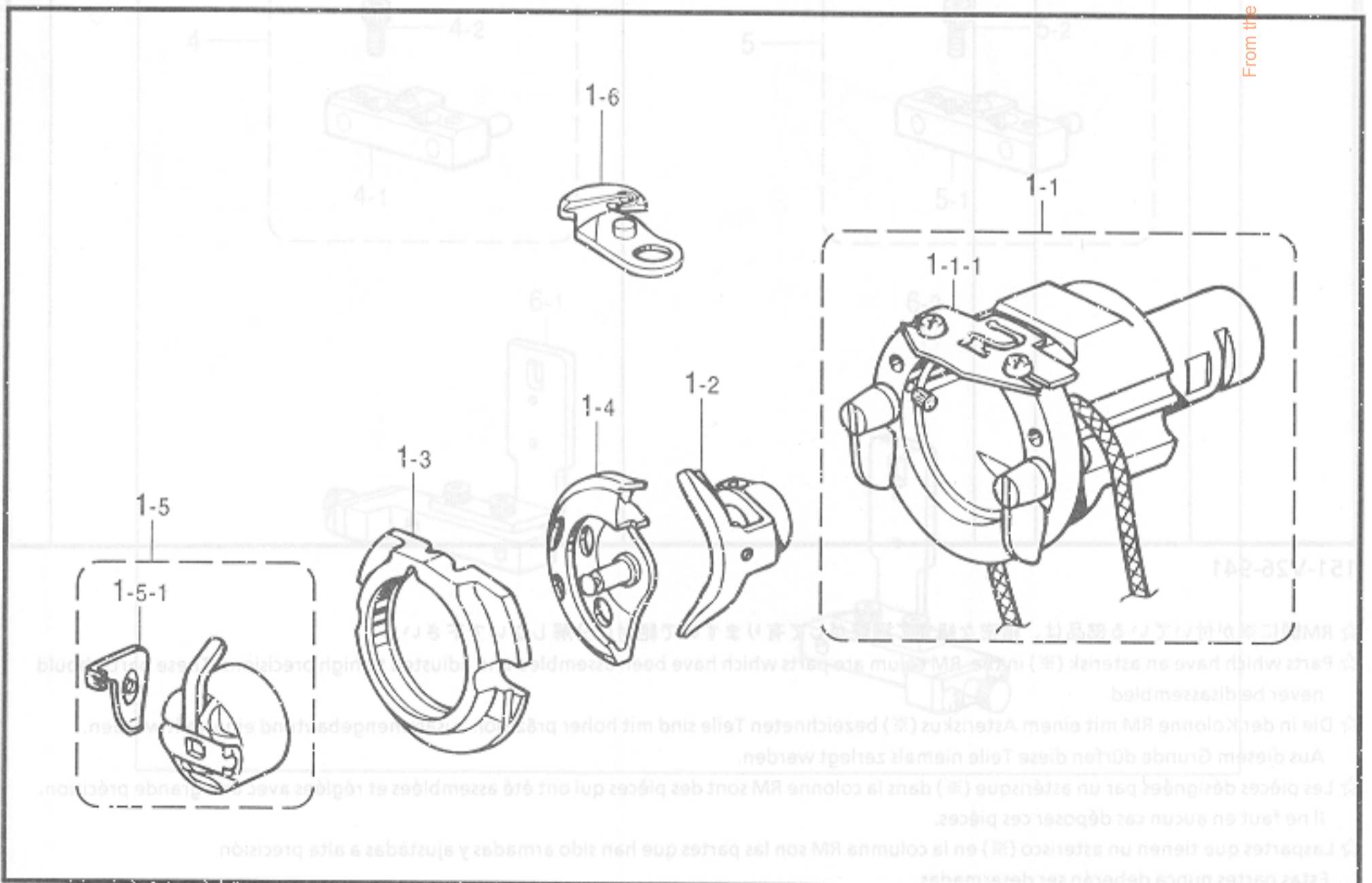

From the library of: Diamond Needle Corp

151-V26-946

W. プログラマー関係 (オプション部品) / Programmer (Option parts) / Programmier Vorrichtung (Sonderzubehör) / Programmeur (Pièces en option) / Programador (Piezas opcionales)

REF.NO.	CODE	Q'TY	ヒンメイ	NAME OF PARTS	RM
1	S43249001	1	プログラマクミ	PROGRAMMER ASSY	
1-1	S43250000	1	プログラマーウエフタ	TOP COVER, PROGRAMMER	
1-2	S43251000	1	プログラマーシタフタ	LOWER COVER, PROGRAMMER	
1-3	S43252000	1	キーボードスヘーサ	SPACER, KEYBOARD	
1-4	S43253000	1	キーボードゴムシート	RUBBER SHEET, KEYBOARD	
1-5	S43254000	1	キーボードシート	KEYBOARD SHEET	
1-6	037301015	4	Vナベタツピン3X10	TAPPING SCREW, PAN V M3X10	
1-7	S43255000	1	LCDカバー	LCD COVER	
1-8	S43256000	1	LCD	LCD	
1-9	S43257000	1	LCDヨウインバーター	INVERTER, LCD	
1-10	037200615	4	Vナベタツピン2X6	TAPPING SCREW, PAN V M2X6	
1-11	S43271000	1	プログラマーマグネットA	MAGNET, A	
1-12	S43272000	1	プログラマーマグネットB	MAGNET, B	
1-13	037300615	6	Vナベタツピン3X6	TAPPING SCREW, PAN V M3X6	
1-14	S43267000	1	プログラマーコード	PROGRAMMER HARNESS	
1-15	S43268000	1	インバーターハーネス	INVERTER HARNESS	
1-16	S43270000	1	コードブツシユKR51	CORD BUSH, KR51	
1-17	S43981000	2	プログラマーシタカバー	LOWER COVER, PROGRAMMER	
1-18	S43259001	1	プログラマキバンクミ	PROGRAMMER PCB ASSY	
1-19	S43269000	1	PROMプログラマクミ	PROM PROGRAMMER ASSY	
2	S40621000	1	” オプション部品 ” EMIコアESD-SR-15	” OPTION PARTS ” EMI CORE, ESD-SR-15	
3	149809000	1	タイラツPL	BEAD BAND, L = 200	

151-V26-942

X. ワイドパーフェクト装置関係 (オプション部品) / Wide perfect device (Option parts) / Wide-perfect-Vorrichtung (Sonderzubehör) / Dispositif de perfection large (Pièces en option) / Dispositivo de ancho perfecto (Piezas opcionales)

REF.NO.	CODE	Q'TY	ヒンメイ	NAME OF PARTS	RM
1	S44795001	1	300Eワイドフセット	WIDE PERFECT STITCH SET, 300E	
1-1	S40837001	1	Z11オオカマタイWPクミ	SHUTTLE RACE BASE ASSY, WP	
1-1-1	S40839001	1	カマイトアンナイWP	THREAD GUIDE, WP S-RACE BODY	
1-2	S40840001	1	ドライバーWP	DRIVER, WP	
1-3	S40841001	1	オオカマWP	SHUTTLE RACE BODY, WP	
1-4	S40842991	1	ナカカマWPハコクミ	SHUTTLE HOOK, WP W/BOX	
1-5	S40843001	1	ボビンケースクミWP	BOBBIN CASE ASSY, WP	
1-5-1	S40845001	1	ケースチヨウシバネWP	TENSION SPRING, WP	
1-6	S40846001	1	イドウハWPクミ	MOVABLE KNIFE ASSY, WP	
1-11-7-1	S44746000	1	ワイカバルブ	VALVE HARNESS	
1-11-7-2	S44750000	1	ワイカバルブ	VALVE HARNESS, 24V	
1-11-8	S18415101	2	ハーフユニオン	HALF UNION, Q4R75	
1-11-9	S45252000	1	レギュレーター	REGULATOR ASSY	
1-11-9-1	S45253000	1	レギュレーター	REGULATOR	
1-11-9-2	S45254000	2	ツキ	JOINT, 3109-4-10	
1-11-10	S62404005	2	ネジ	SCREW, PAN M4X40	
1-12	S40840001	2	ユニタイバンド	BEAD BAND	
1-13	S03892000	2	ナイロンチューブ	AIR TUBE, 4 L = 1300	
1-14	S42741000	1	エアチューブ	AIR TUBE, 4 L = 300	
11	S44426001	1	” 補給用部品 ” ソトオサエア	” For Supply parts ” OUTER WORK CLAMP, 326E-2	
12	S51076001	1	ソトオサエア	OUTER WORK CLAMP, 326L-3	
13	S10582001	1	サエ	INNER CLAMP, LL	
14	S51077001	1	オサエ	WORK CLAMP BLANK, A 326L	
15	S51078001	1	ソトオサエア	OT-FEED PLATE BLANK, H 326L	

151-V26-946

Y. 中押工反転装置関係 (オプション部品) / Inner clamping device (Option parts)

/ Innere Feststellvorrichtung (Sonderzubehör) / Dispositif de griffe intérieure (Pièces en option)

/ Dispositivo Prensor interior (Piezas opcionales)

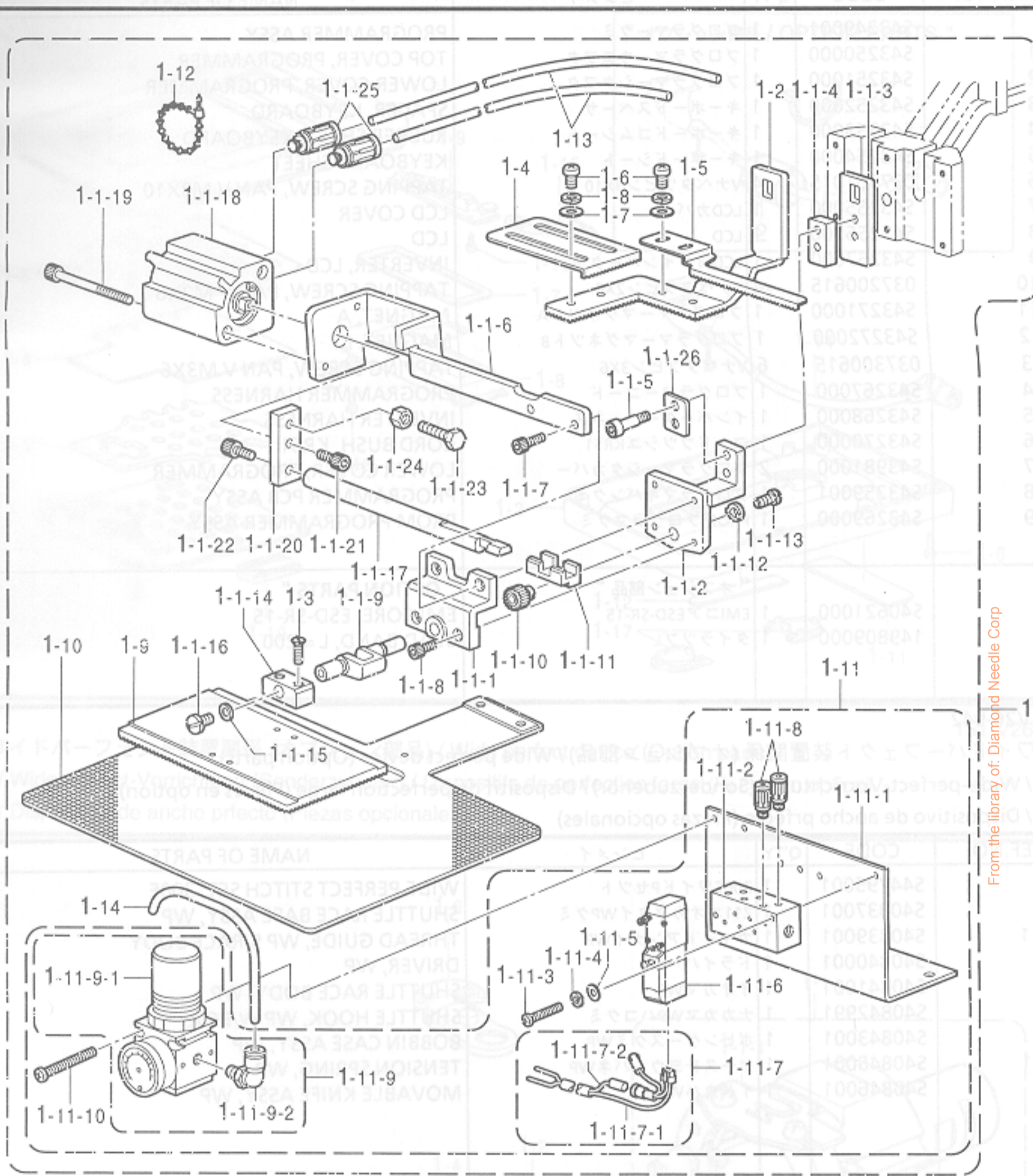

From the library of: Diamond Needle Corp

" 補給用部品 / For Supply parts "

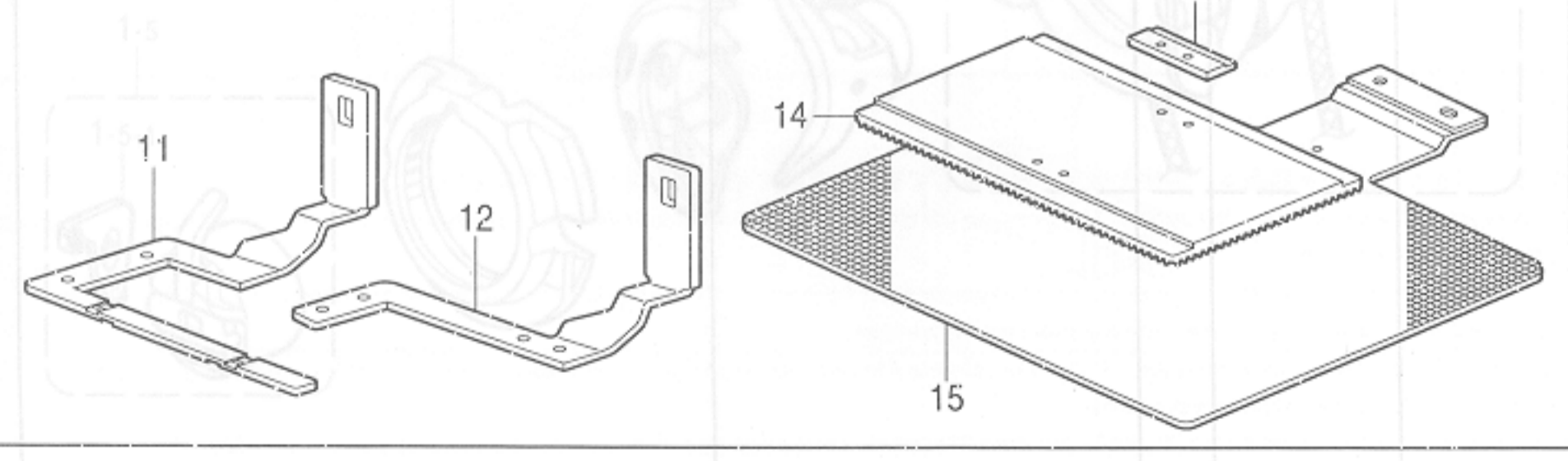

Y. 中押エ反転装置関係 (オプション部品) / Inner clamping device (Option parts)
 / Innere Feststellvorrichtung (Sonderzubehör) / Dispositif de griffe intérieure (Pièces en option)
 / Dispositivo prensor interior (Piezas opcionales)

REF.NO.	CODE	Q'TY	ヒンメイ	NAME OF PARTS	RM
1	S51073009	1	ネームツケハンテンソウチセット	INNER CLAMPING DEVICE SET, 326E	
1-1	S44420009	1	オサエクランクLAクミ	WORK CLAMP CRANK ASSY, LA	
1-1-1	S12634009	1	オサエクランクホルダA	WORK CLAMP CRANK HOLDER, A	
1-1-2	S12635009	1	オサエクランクホルダB	WORK CLAMP CRANK HOLDER, B	
1-1-3	S44421001	1	オサエクランクホルダC	WORK CLAMP CRANK HOLDER, C	
1-1-4	S44422001	1	クランクホルダカンザ	SPACER, CRANK HOLDER	
1-1-5	150382001	2	アナボルト4.37X18	BOLT, SOCKET SM4.37X18	
1-1-6	S12638009	1	ハンテンシリンダダイ	REVERSE CYLINDER BRACKET	
1-1-7	018301236	2	アナボルト3X12	BOLT, SOCKET M3X12	
1-1-8	018301036	2	アナボルト3X10	BOLT, SOCKET M3X10	
1-1-9	S05665001	1	オサエクランクLA	WORK CLAMP CRANK, LA	
1-1-10	154235001	1	ハンテンギヤ	REVERSE GEAR	
1-1-11	154236001	1	ハンテンラック	REVERSE RACK	
1-1-12	145087001	1	ハンテンギヤザガネ	WASHER	
1-1-13	149831101	1	アタマツキトメネジ3.18	SET SCREW, SM3.18	
1-1-14	154237001	1	オサエイタホルダL	WORK CLAMP PLATE HOLDER, L	
1-1-15	025350132	1	ヒラザガネシヨウ	WASHER, PLAIN S 3.5	
1-1-16	100242003	1	シメネジ3.57	SCREW, SM3.57	
1-1-17	S12637009	1	ハンテンロッド	REVERSE ROD	
1-1-18	S12639001	1	ハンテンシリンダ	REVERSE CYLINDER	
1-1-19	S12642009	2	アナボルト3X35	BOLT, SOCKET M3X35	
1-1-20	S12640009	1	ハンテンジクツギテ	JOINT	
1-1-21	018300836	1	アナボルト3X8	BOLT, SOCKET M3X8	
1-1-22	018300836	1	アナボルト3X8	BOLT, SOCKET M3X8	
1-1-23	017501216	1	ボルト5X12	BOLT, M5X12	
1-1-24	021500216	1	2シユナツト5	NUT, 2 M5	
1-1-25	S18415101	2	ハーフユニオンQ4M5	HALF UNION, Q4M5	
1-1-26	S44424001	1	クランクホルダスベサ	SPACER, CRANK HOLDER	
1-2	S44425001	1	ソトオサエアシ326E-1	OUTER WORK CLAMP, 326E-1	
1-3	117291002	2	サラネジ3.18	SCREW, FLAT SM3.18	
1-4	154252001	1	イチギメイタL	POSITIONING PLATE, L	
1-5	154253001	1	イチギメイタR	POSITIONING PLATE, R	
1-6	062670512	4	ナベコ357-40X5	SCREW, PAN SM3.57-40X5	
1-7	025350332	4	ヒラザガネダイ3.5	WASHER, PLAIN L 3.5	
1-8	028350242	4	バネザガネ2-3.5	WASHER, SPRING 2-3.5	
1-9	154256101	1	オサエイタブランクA	WORK CLAMP PLATE BLANK, A	
1-10	S51075001	1	オクリイタブランクLH ... t=1.2	FEED PLATE BLANK, H 326L t=1.2	
1-11	S44745009	1	ハンテンバルブ3クミ	INNER CLAMP VALVE ASSY, 3	
1-11-1	S31570209	1	バルブトリツケイタ4-5H	VALVE SETTING PLATE, 4-5H	
1-11-2	S44748001	1	エアマニホルド3	AIR MANIFOLD, 3	
1-11-3	062302506	2	ナベコ3X25	SCREW, PAN M3X25	
1-11-4	028030242	2	バネザガネ2-3	WASHER, SPRING 2-3	
1-11-5	025030232	2	ヒラザガネチユウ3	WASHER, PLAIN M 3	
1-11-6	S43683001	1	デンジバルブ	SOLENOID VALVE	
1-11-7	S43696000	1	バルブハーネスX1	VALVE HARNESS, X1	
1-11-7-1	S44746000	1	ツイカバルブハーネス	VALVE HARNESS	
1-11-7-2	S44750000	1	ツイカバルブハーネス24V	VALVE HARNESS, 24V	
1-11-8	S18415101	2	ハーフユニオンQ4M5	HALF UNION, Q4M5	
1-11-9	S45252000	1	レギュレータクミ	REGULATOR ASSY	
1-11-9-1	S45253000	1	レギュレータ	REGULATOR	
1-11-9-2	S45254000	2	ツギテ3109-4-10	JOINT, 3109-4-10	
1-11-10	062404005	2	ナベコ4X40	SCREW, PAN M4X40	
1-12	340400001	2	ユニタイバンド	BEAD BAND	
1-13	S03803000	2	ナイロンチューブ	AIR TUBE, 4 L = 1300	
1-14	S28741000	1	エアーチューブ	AIR TUBE, 4 L = 300	
11	S44426001	1	" 補給用部品 "	" For Supply parts "	
12	S51076001	1	ソトオサエアシ326E-2	OUTER WORK CLAMP, 326E-2	
13	S10542001	1	ソトオサエアシ326L-3	OUTER WORK CLAMP, 326L-3	
14	S51077001	1	ナカオサエLL	INNER CLAMP, LL	
15	S51078001	1	オサエイタブランクA326L	WORK CLAMP BLANK, A 326L	
			OTオクリイタブランクLH t=1.2	OT-FEED PLATE BLANK, H 326L t=1.2	

From the library of: Diamond Needle Corp

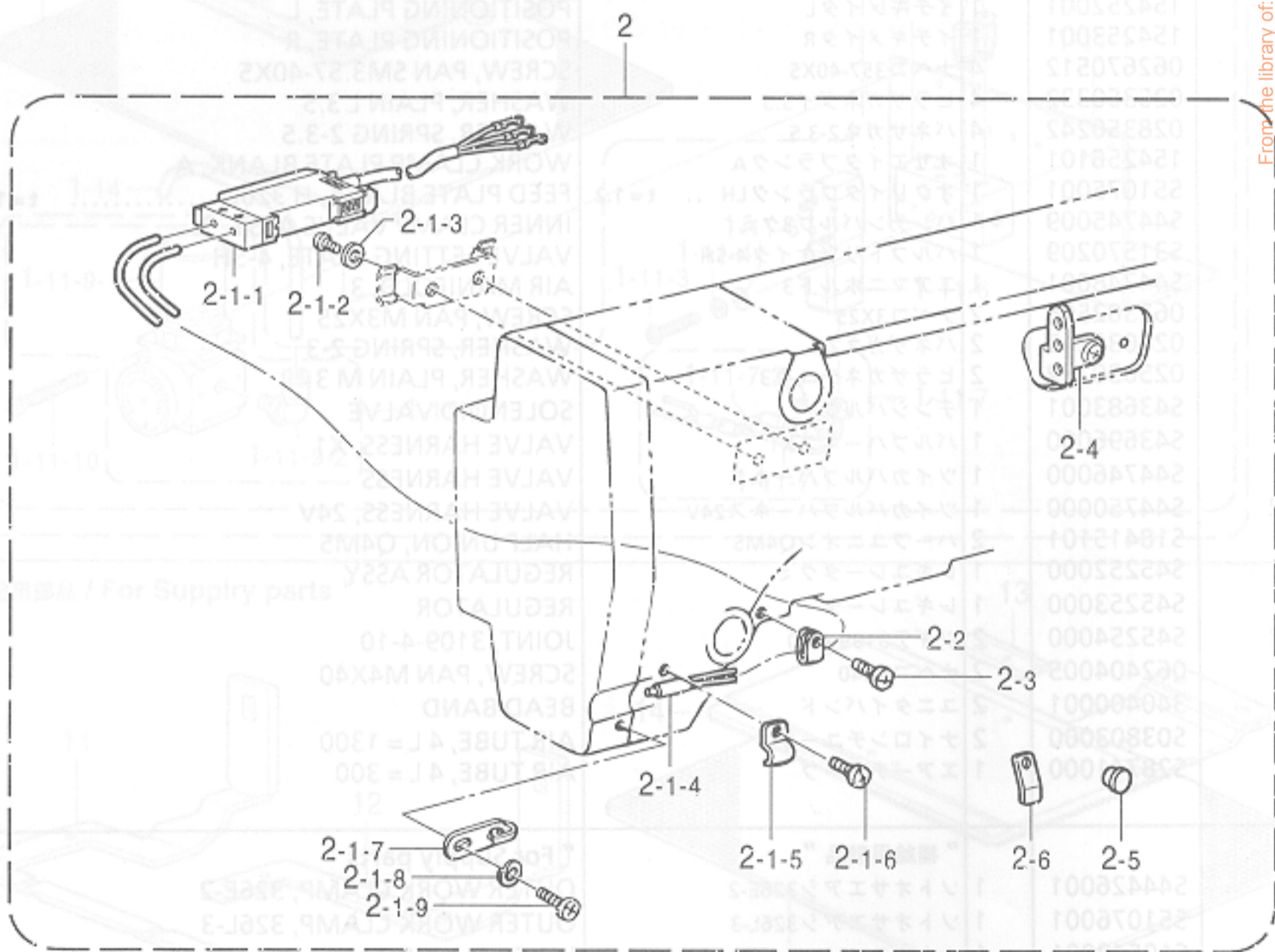
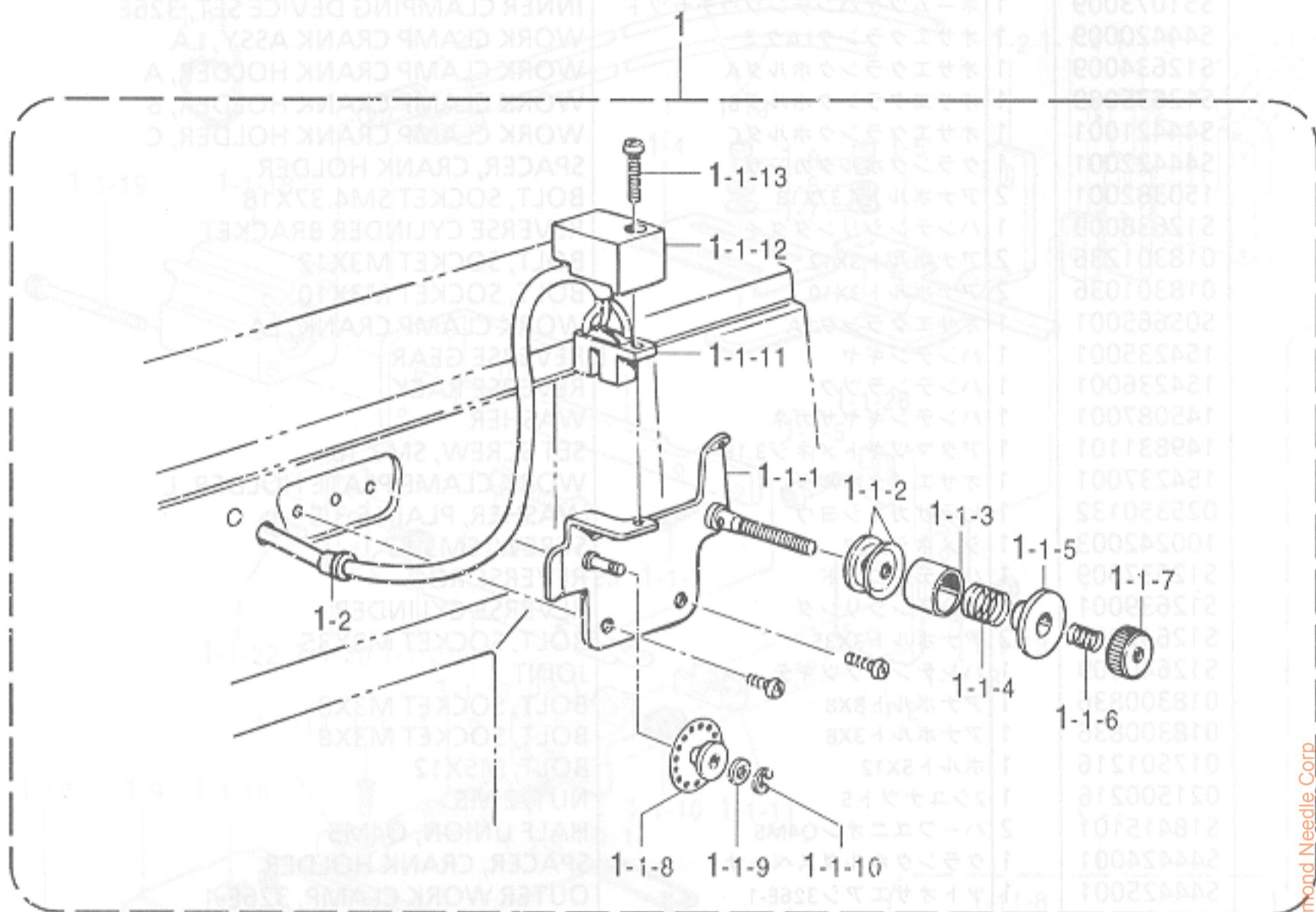

From the library of: Diamond Needle Corp

AA1. 補助装置関係 (オプション部品) / Auxiliary device (Option parts) / Hilfsvorrichtung (Sonderzubehör)
 / Dispositif auxiliaire (Pièces en option) / Dispositivo auxiliar (Piezas opcionales)

REF.NO.	CODE	Q'TY	ヒンメイ	NAME OF PARTS	RM
			"糸切れ感知装置"	"Thread breakage detector"	
			<プーリー式>	<Pulley type>	
1	S43833109	1	イトキレカンチソウチセットR	TR. BREAKAGE DETECTOR SET, R	
1-1	S43834109	1	ロータリーイトキレカンチクミ	TR. BREAKAGE DETECTOR ASSY, R	
1-1-1	S18032001	1	イトキレカンチブラケットクミ	DETECTOR BRACKET ASSY	
1-1-2	144504001	2	イトアンナイサラ	DISC, THREAD GUIDE	
1-1-3	146206009	1	イトアンナイサラオサエ	DISC PRESSER, THREAD GUIDE	
1-1-4	146058001	1	プレテンションバネ	PRE-TENSION SPRING	
1-1-5	146059001	1	プレテンションナツト	PRE-TENSION NUT	
1-1-6	146060000	1	ナツトオシバネ	SPRING	
1-1-7	155510001	1	イトチヨウシナツト	TENSION NUT	
1-1-8	157255100	1	プーリーA	PULLEY, A	
1-1-9	025030135	1	ヒラザガネシヨウ3	WASHER, PLAIN S 3	
1-1-10	048020342	1	トメワE2	RETAINING RING, E2	
1-1-11	S43835100	1	イトキレフオトセンサークミ	SENSOR ASSY	
1-1-12	S18037009	1	センサーカバー	SENSOR COVER	
1-1-13	062301616	1	ナベコM3X16	SCREW, PAN M3X16	
1-2	146080000	1	コードブシュ	CORD BUSH	
			<ビームセンサー式>	<Beam sensor type>	
2	S43836301	1	イトキレカンチソウチセットF	TR. BREAKAGE DETECTOR SET, F	
2-1	S43977201	1	イトキレカンチFクミ	TR. BREAKAGE DETECTOR ASSY, F	
2-1-1	S43279200	1	アンプユニット	AMPLIFIER UNIT	
2-1-2	062300612	2	ナベコ3X6	SCREW, PAN M3X6	
2-1-3	025030232	2	ヒラザガネチユウ3	WASHER, PLAIN M 3	
2-1-4	S29468100	1	ファイバユニットN	FIBER UNIT, N	
2-1-5	S11884001	1	センサートリツケイタ	SENSOR SETTING PLATE	
2-1-6	062300612	1	ナベコ3X6	SCREW, PAN M3X6	
2-1-7	S02617001	1	メンイタイトアンナイ	THREAD GUIDE, FACE PLATE	
2-1-8	028350242	1	バネザガネ2-3.5	WASHER, SPRING 2-3.5	
2-1-9	060670612	1	バインド357-40X6	SCREW, BIND SM3.57-40X6	
			<BAS-311E, 311EL用>	<For BAS-311E & 311EL>	
2-2	625010000	1	ナイロンランプNK-2N	CORD HOLDER, NK-2N	
2-3	060670612	1	バインド357-40X6	SCREW, BIND SM3.57-40X6	
			<BAS-341E, 342E, 343E用>	<For BAS-341E, 342E & 343E>	
2-4	152889001	1	ミツメイトカケ	THREAD RETAINER	
2-5	117936009	2	ゴムセン9.4	RUBBER CAP, 9.4	
2-6	S02657101	1	コードオサエ	CORD HOLDER	
			<ソフト押エキ>	<Soft work clamp set>	
5	S00000000	1	ソフトオサエセット	SOFT WORK CLAMP SET	
5-1	S00000000	2	ソフトオサエバネ	SPRING	
5-2	S00000000	2	アンナイ	UNION, YA	
5-3	S00000000	2	エアチューブ	AIR TUBE, 4 L=200	
5-4	S00000000	2	プラグ	PLUG, 4	

From the library of: Diamond Needle Corp

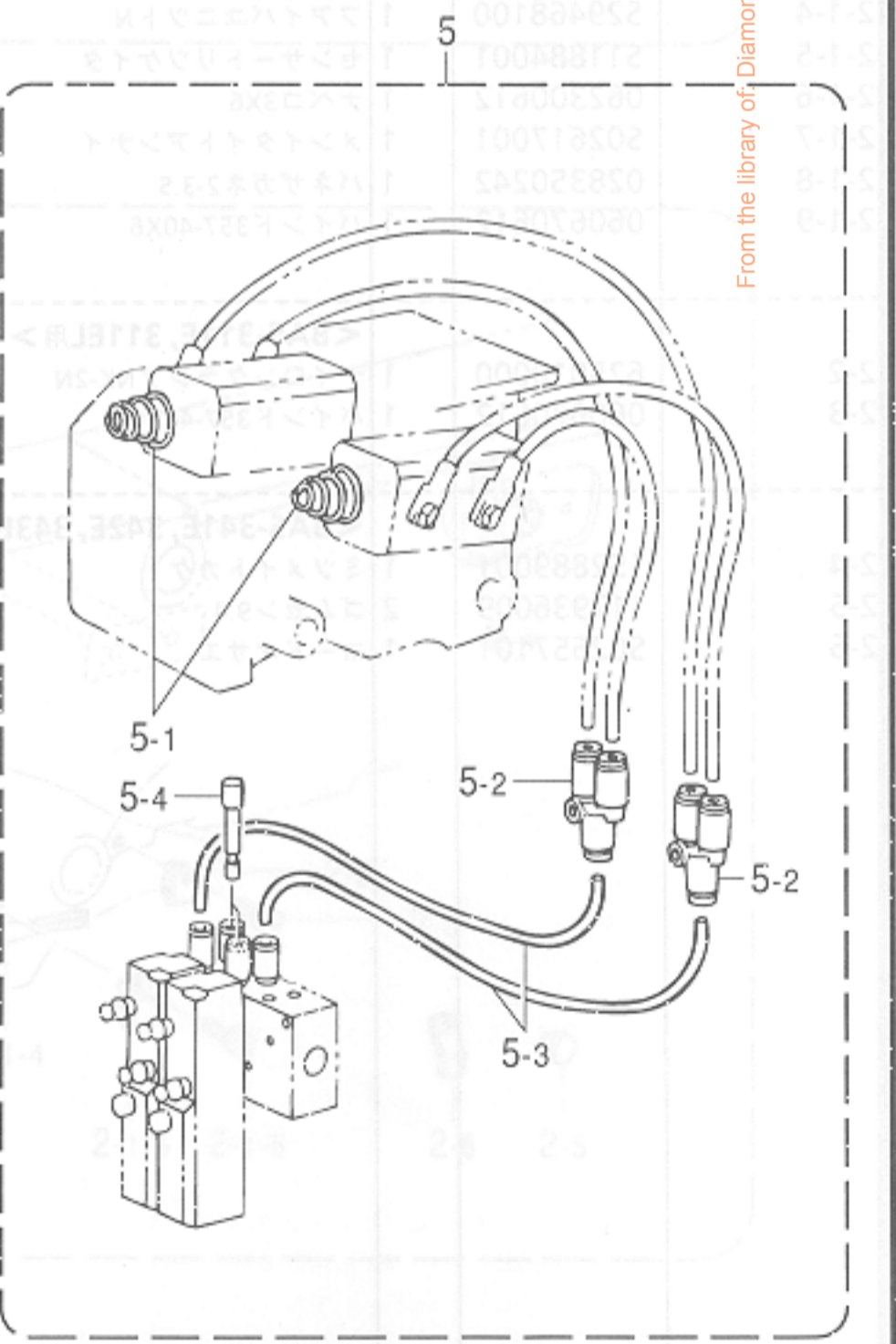
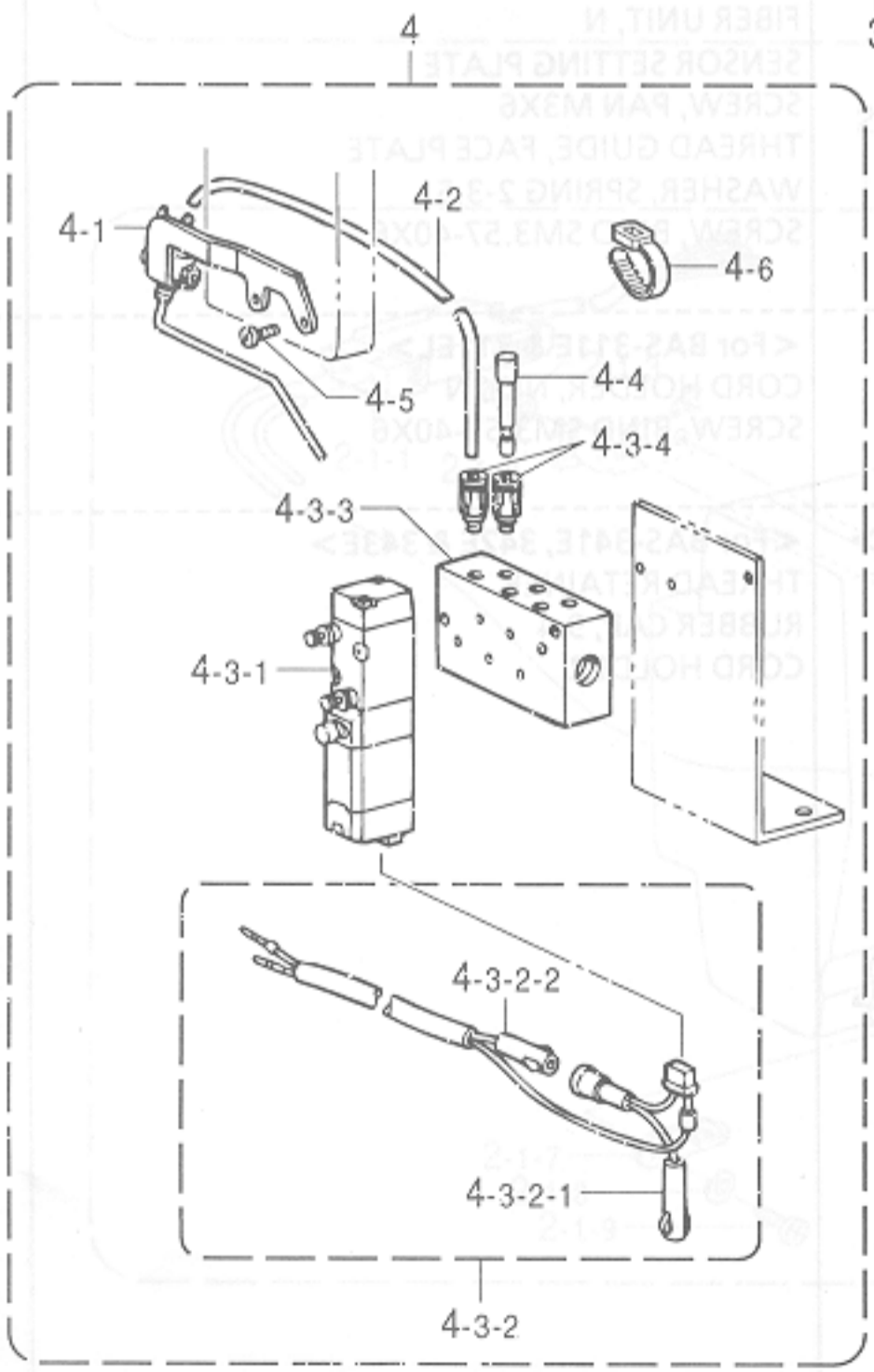
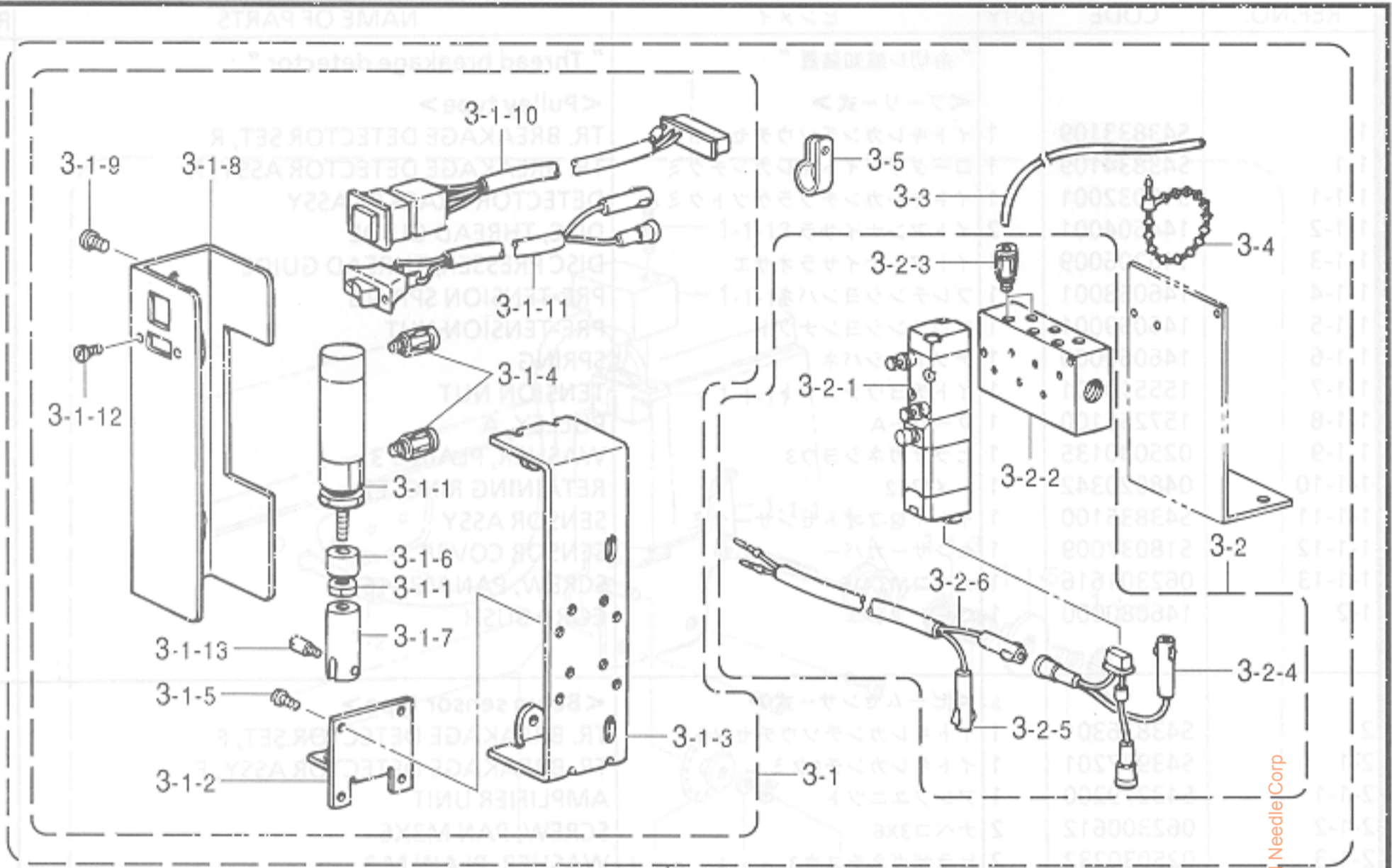

From the library of: Diamond Needle Corp

AA2. 補助装置関係 (オプション部品) / Auxiliary device (Option parts) / Hilfsvorrichtung (Sonderzubehör)
 / Dispositif auxiliaire (Pièces en option) / Dispositivo auxiliar (Piezas opcionales)

REF.NO.	CODE	Q'TY	ヒンメイ	NAME OF PARTS	RM
			<エアワイパー装置>	<Air wiper set>	
3	S43841009	1	エアワイパーソウチクミ	TR. WIPER SET, PNEUMATIC TYPE	
3-1	S43842009	1	エアワイパークミ	TR. WIPER ASSY, PNEUMATIC TYPE	
3-1-1	S17942000	1	エアシリンダ	AIR CYLINDER	
3-1-2	S31777001	1	シリンダトリツケイタ	CYLINDER SUPPORT PLATE	
3-1-3	S10214109	1	ソレノイドトリツケイタ	SETTING PLATE, SOLENOID	
3-1-4	S18415101	2	ハーフユニオンQ4M5	HALF UNION, Q4M5	
3-1-5	062670612	4	ナベコ357-40X6	SCREW, PAN SM3.57-40X6	
3-1-6	S31778000	1	シリンダーストツバ	STOPPER, CYLINDER	
3-1-7	S31779001	1	シリンダーツギテ	JOINT, CYLINDER	
3-1-8	S31776109	1	シリンダーカバー	CYLINDER COVER	
3-1-9	062680512	2	ナベコ437-40X5	SCREW, PAN SM4.37-40X5	
3-1-10	S43203000	1	EMスイッチクミ	EM-SWITCH ASSY	
3-1-11	S43843009	1	イトハライスイッチクミ	THREAD WIPER SWITCH ASSY	
3-1-12	062300612	2	ナベコ3X6	SCREW, PAN M3X6	
3-1-13	S02680001	1	フランジヤピン	PLUNGER PIN	
3-2	S43844001	1	AWデンジバルブ3クミ	AW-SOLENOID VALVE ASSY, 3	
3-2-1	S43683001	1	デンジバルブ	SOLENOID VALVE	
3-2-2	S44748001	1	エアマニホルド3	AIR MANIFOLD, 3	
3-2-3	S18415101	2	ハーフユニオンQ4M5	HALF UNION, Q4M5	
3-2-4	S44759000	1	AWバルブハーネスA	AW-VALVE HARNESS, A	
3-2-5	S44760000	1	AWバルブハーネスB	AW-VALVE HARNESS, B	
3-2-6	S44750000	1	ツイカバルブハーネス24V	VALVE HARNESS, 24V	
3-3	S15031008	2	エアチューブ	AIR TUBE, 4 L = 1900	
3-4	340400001	7	ユニタイバンド	BEAD BAND	
3-5	149287000	4	ナイロンクランプ	CORD HOLDER, 7N	
			<ニードルクーラー装置>	<Needle cooler set>	
4	S43846009	1	ニードルクーラーソウチセット	NEEDLE COOLER SET	
4-1	S18027101	1	ニードルブロワー	NEEDLE BLOWER	
4-2	S15031008	1	エアチューブ	AIR TUBE, 4 L = 1900	
4-3	S43839008	1	デンジバルブOP3クミ	SOLENOID VALVE ASSY, OP3	
4-3-1	S43683001	1	デンジバルブ	SOLENOID VALVE	
4-3-2	S43696000	1	バルブハーネスX1	VALVE HARNESS, X1	
4-3-2-1	S44746000	1	ツイカバルブハーネス	VALVE HARNESS	
4-3-2-2	S44750000	1	ツイカバルブハーネス24V	VALVE HARNESS, 24V	
4-3-3	S44748001	1	エアマニホルド3	AIR MANIFOLD, 3	
4-3-4	S18415101	2	ハーフユニオンQ4M5	HALF UNION, Q4M5	
4-4	S04897000	1	プラグ4	PLUG, 4	
4-5	062670812	2	ナベコ3.57-40X8	SCREW, PAN SM3.57-40X8	
4-6	228475000	3	ケツソクバンド1.9X80	FASTENING BAND, 1.9X80	
			<ソフト押エセット>	<Soft work clamp set>	
5	S44450001	1	ソフトオサエセット	SOFT WORK CLAMP SET	
5-1	S44412001	2	ソフトオサエバネ	SPRING	
5-2	S12104000	2	ユニオンワイ4	UNION, Y4	
5-3	S08140000	2	エアホースS-C	AIR TUBE, 4 L = 200	
5-4	S04897000	2	プラグ4	PLUG, 4	

From the library of: Diamond Needle Corp

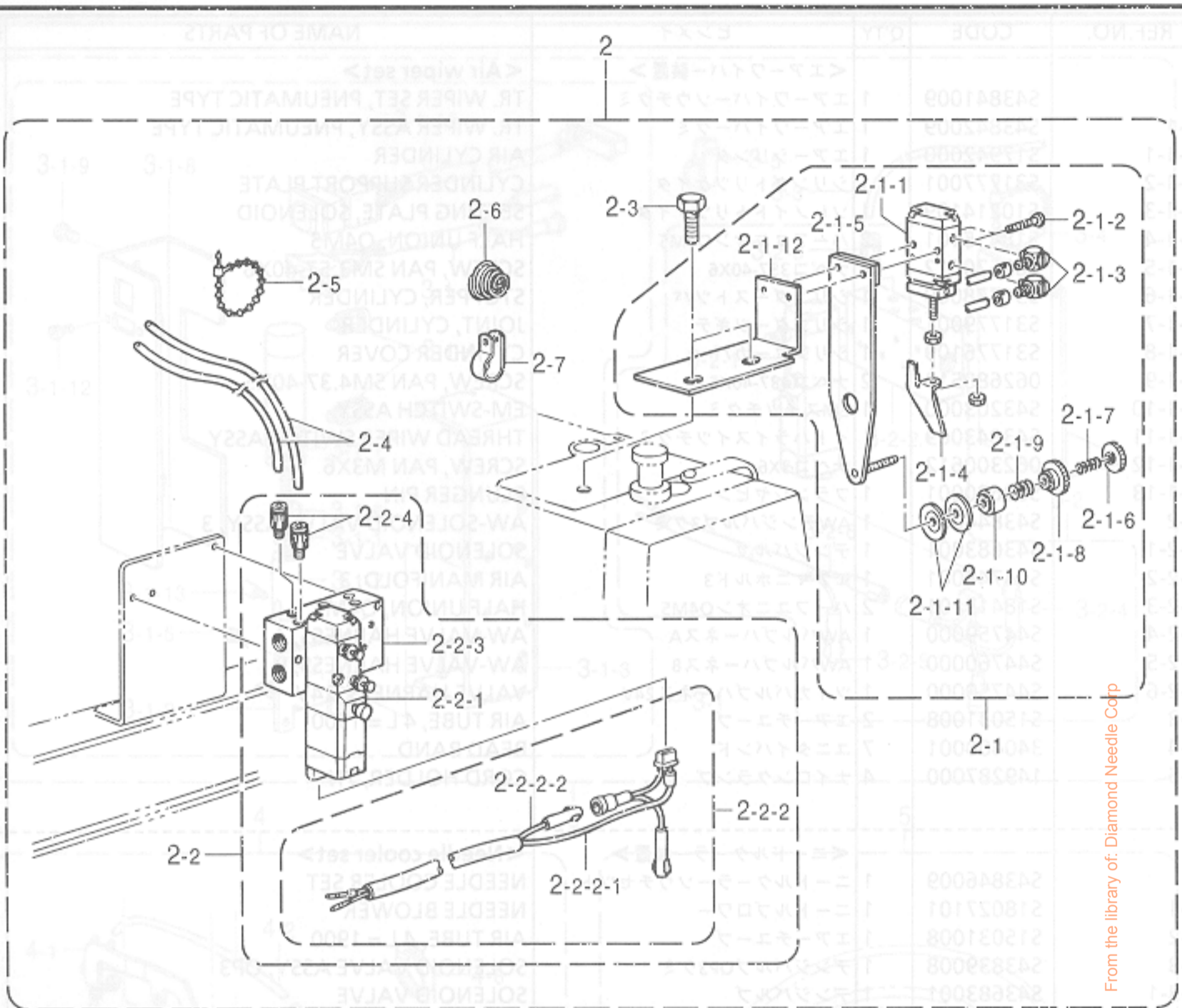

From the library of: Diamond Needle Corp

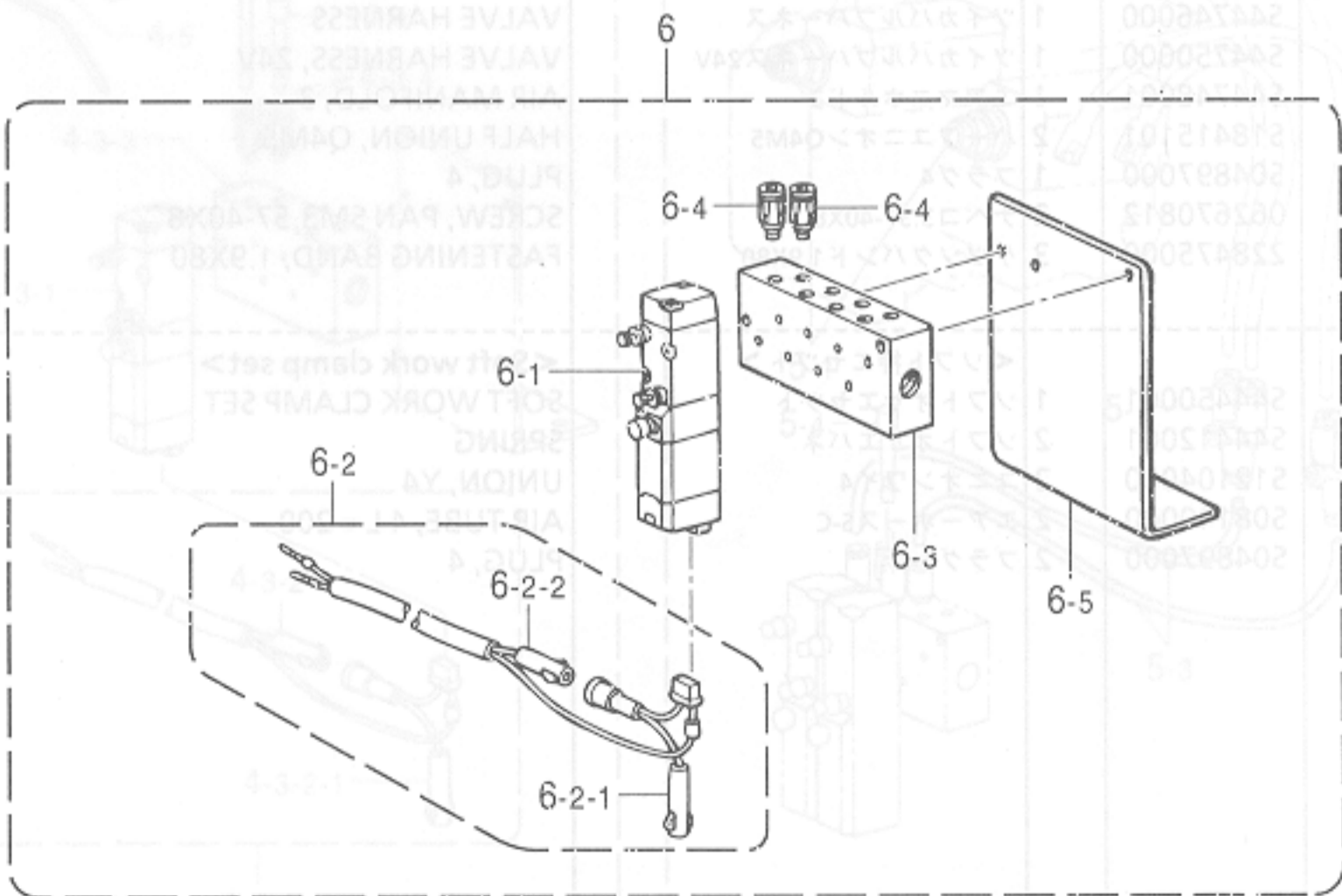

AA3. 補助装置関係 (オプション部品) / Auxiliary device (Option parts) / Hilfsvorrichtung (Sonderzubehör)
 / Dispositif auxiliaire (Pièces en option) / Dispositivo auxiliar (Piezas opcionales)

REF.NO.	CODE	Q'TY	ヒンメイ	NAME OF PARTS	RM
			<2段糸調子装置>	<2-step tension device>	
2	S43837001	1	2ダンTソウチセット1	2-STEP THREAD TENSION DEVICE SET, 1	
2-1	S43838001	1	2ダンテンションクミ	2-STEP THREAD TENSION ASSY	
2-1-1	S34706000	1	エアーシリンダ10X10	AIR CYLINDER, 10X10	
2-1-2	018302032	2	アナボルト3X20	BOLT, SOCKET M3X20	
2-1-3	S12150000	2	ホースエルボM-5HL-4	TUBE ELBOW, M-5HL-4	
2-1-4	S34533001	1	サラワリツメ	COUNTERSINK CLAW	
2-1-5	S34534001	1	サブテンションダイクミ	SUB TENSION BRACKET ASSY	
2-1-6	155510001	1	イトチヨウシナツト	TENSION NUT	
2-1-7	146060000	1	ナツトオシバネ	SPRING	
2-1-8	146059001	1	プレテンションナツト	PRE-TENSION NUT	
2-1-9	146058001	1	プレテンションバネ	PRE-TENSION SPRING	
2-1-10	146206009	1	イトアンナイサラオサエ	DISC PRESSER, THREAD GUIDE	
2-1-11	144504001	2	イトアンナイサラ	DISC, THREAD GUIDE	
2-1-12	S34536001	1	シリンダートリツケイタ	CYLINDER SETTING BRACKET	
2-2	S43839005	1	デンジバルブOP3クミ	SOLENOID VALVE ASSY, OP3	
2-2-1	S43683001	1	デンジバルブ	SOLENOID VALVE	
2-2-2	S43696000	1	バルブハーネスX1	VALVE HARNESS, X1	
2-2-2-1	S44746000	1	ツイカバルブハーネス	VALVE HARNESS	
2-2-2-2	S44750000	1	ツイカバルブハーネス24V	VALVE HARNESS, 24V	
2-2-3	S44748001	1	エアマニホルド3	AIR MANIFOLD, 3	
2-2-4	S18415101	2	ハーフユニオンQ4M5	HALF UNION, Q4M5	
2-3	017821813	2	ボルト7.94X18	BOLT, SM7.94X18	
2-4	S15031008	2	エアーチューブ	AIR TUBE, 4 L = 1900	
2-5	340400001	5	ユニタイバンド	BEAD BAND	
2-6	104525001	1	イトチヨウシバネ	SPRING, TENSION	
2-7	149287000	3	ナイロンクランプ	CORD HOLDER, 7N	
			<追加バルブセット>	<Addition valve set>	
6	S43847101	1	デンジバルブOP4クミ	SOLENOID VALVE ASSY, OP4	
6-1	S43683001	1	デンジバルブ	SOLENOID VALVE	
6-2	S43696000	1	バルブハーネスX1	VALVE HARNESS, X1	
6-2-1	S44746000	1	ツイカバルブハーネス	VALVE HARNESS	
6-2-2	S44750000	1	ツイカバルブハーネス24V	VALVE HARNESS, 24V	
6-3	S44749001	1	エアマニホルド4	AIR MANIFOLD, 4	
6-4	S18415101	2	ハーフユニオンQ4M5	HALF UNION, Q4M5	
6-5	S31554009	1	バルブトリツケイタ4-5	SETTING PLATE, 4-5 VALVE	
27	118817001	1	ネジマフシ3.4X70	SCREW DRIVER, 3.4X70	
28	101399119	1	ネジマフシ5.5X190	SCREW DRIVER, 5.5X190	
29	107705001	1	スリナ6X	WRENCH, 6X	
30	107706001	1	スリナ8X	WRENCH, 8X	
31	107780001	1	スリナ10X12	WRENCH, 10X12	
32	107725001	1	六角ボウスパナ3	HEXAGONAL WRENCH, 3	
33	107726001	1	六角ボウスパナ4	HEXAGONAL WRENCH, 4	
34	107763001	1	イトタテダイクミDR	COTTON STAND ASSY, 2DR	
34-1	107764001	1	ウケザラ	SPOOL STAND BASE	
34-2	107765001	1	スプールマフ	SPOOL MAT	
34-3	107766001	1	スプールクッション	SPOOL CUSHION	
34-4	107772001	1	パイプ(D)ネジセットB	PIPE (D) SCREW SET, B	
34-4-1	107773001	1	ワッシャー16	WASHER, PLAIN 16	
34-4-2	107774001	1	ナットUS/28	NUT, US/28	
34-4-3	107775001	1	コラムキャップ	COLUMN CAP	

From the library of: Diamond Needle Corp

Z. 付属品関係 / Accessories / Zubehör / Accessoires / Accesorios

REF.NO.	CODE	Q'TY	ヒンメイ	NAME OF PARTS	RM
1	S44369009	1	ベルトカバー326クミ	BELT COVER ASSY, 326	
1-1	S44370009	1	ベルトカバー326	BELT COVER, 326	
1-2	104450109	1	ゴムセン8	RUBBER CAP, 8	
3	062401006	1	ナベコ4X10	SCREW, PAN M4X10	
4	S38039109	1	オイルパンクミ	OIL PAN ASSY	
4-1	S38040109	1	オイルパン	OIL PAN	
4-2	154467001	1	ハイユキヤツブ	DUST OILER	
4-3	037301215	2	Vナベタツピン3X12	TAPPING SCREW, PAN V M3X12	
4-4	S18093100	1	クミヒモ4X4	WICK, 4X4 L = 1100	
5	109714000	5	クギ	NAIL	
6	114486002	1	ポリオイラータイ	OILER	
9	143882001	2	トウブヒンジ	HEAD HINGE	
10	014760622	2	アナトメネジ5.95	SET SCREW, SOCKET SM5.95	
11	143910009	2	トウブヒンジウケゴム	RUBBER CUSHION	
12	109714000	4	クギ	NAIL	
13	S18707149	1	VベルトMシロ	BELT, VM WHITE	
14	122991001	1	フゾクヒンポリフクロ	ACCESSORY BAG	
15	S06706001	1	シリコンオイル	SILICONE OIL	
16	S15665001	3	ボビンLA	BOBBIN, LA	
17	107415416	1	<中厚物用> ミシンハリDPX5#16クミ	<For Medium-weight materials> NEEDLE ASSY, DPX5 (#16)	
17	145646421	1	<厚物用> ミシンハリDPX17#21クミ	<For Heavy-weight materials> NEEDLE ASSY, DPX17 (#21)	
18	S10208001	1	イドウハカンザ t=0.4	SPACER, MOVABLE KNIFE T = 0.4 t=0.4	
18	S10208002	1	イドウハカンザ t=0.5	SPACER, MOVABLE KNIFE T = 0.5 t=0.5	
18	S10208003	1	イドウハカンザ t=0.6	SPACER, MOVABLE KNIFE T = 0.6 t=0.6	
19	S45724009	1	マクラA	HEAD REST, A	
20	S38043009	2	クツシヨン	CUSHION	
21	109714000	2	クギ	NAIL	
22	114483002	1	ポリオイラークミ	OILER ASSY	
23	154702101	1	オイルタンク	OIL TANK	
24	S08030000	1	Gヒューズ5AFB	FUSE, 5A FB	
25	153242000	1	ヒューズ6A	FUSE, 6A	
26	142443001	1	ネジマワシ1.9X52	SCREW DRIVER, 1.9X52	
27	118837001	1	ネジマワシ3.4X70	SCREW DRIVER, 3.4X70	
28	101572101	1	ネジマワシ5.5X190	SCREW DRIVER, 5.5X190	
29	107779001	1	スパナ6X7	WRENCH, 6X7	
30	100887001	1	スパナ8X9	WRENCH, 8X9	
31	107780001	1	スパナ10X12	WRENCH, 10X12	
32	142721001	1	6カクボウスパナ3	HEXAGONAL WRENCH, 3	
33	118064001	1	6カクボウスパナ4	HEXAGONAL WRENCH, 4	
34	S02763302	1	イトタテダイクミ2DR	COTTON STAND ASSY, 2DR	
34-1	150180001	2	ウケザラ	SPOOL STAND BASE	
34-2	150182000	2	スプールのマット	SPOOL MAT	
34-3	126863001	2	スプールのクツシヨン	SPOOL CUSHION	
34-4	S02777001	1	パイプDネジセットB	PIPE (D) SCREW SET, B	
34-4-1	150206002	1	ヒラザガネ16	WASHER, PLAIN 16	
34-4-2	S38648001	1	6カクナットU5/8	NUT, U5/8-28	
34-4-3	150174000	1	コラムキヤツブ	COLUMN CAP	

From the library of: Diamond Needle Corp

151-V26-910

◎ 付属品の明細は変更することがあります。

◎ The details of included accessories are subject to change.

◎ Änderungen in der Aufstellung der Mitgelieferten Zubehöre sind vorbehalten.

◎ Les détails des accessoires inclus sont sujets à des changements.

◎ Los detalles de accesorios incluidos pueden variar.

Z. 付属品関係 / Accessories / Zubehör / Accessoires / Accesorios

REF.NO.	CODE	Q'TY	ヒンメイ	NAME OF PARTS	RM
34-4-4	S01005000	2	イトタテゴム	RUBBER WASHER	
34-4-5	S02747101	1	イトカケバネ	SPRING	
34-5	S40640001	1	コラムパイプキャップツキ	COLUMN PIPE W/CAP	
34-5-1	150174000	1	コラムキャップ	COLUMN CAP	
34-6	156112003	1	コラムパイプD	COLUMN PIPE, D	
34-7	150173003	1	コラムジョイント	COLUMN JOINT	
34-8	S21798001	2	スプールネジセット	SPOOL SCREW SET	
34-8-1	150179002	2	スプールジクB	SPOOL SHAFT, B	
34-8-2	028050246	2	バネザガネ2-5	WASHER, SPRING 2-5	
34-8-3	021500106	2	1シユナツト5	NUT, 1 M5	
34-9	S02778002	1	スプールホルダー2	SPOOL HOLDER, 2	
34-10	S02786002	1	スレツドハンガークミ2	THREAD HANGER ASSY, 2	
34-10-1	S02787002	1	スレツドハンガー2	THREAD HANGER, 2	
34-10-2	150183000	2	イトカケハンガーダイ	THREAD HANGER BASE	
34-10-3	142990001	2	スレツドブツシュ	THREAD BUSH	
34-11	S40641001	1	スプールジクネジセットA	SPOOL SCREW SET, A	
34-11-1	021500106	4	1シユナツト5	NUT, 1 M5	
34-11-2	S37038001	1	ナベコヒラザ5X14	SCREW, PAN (S/P WASHER) M5X14	
34-11-3	S37037001	1	ナベコヒラザ5X32	SCREW, PAN (S/P WASHER) M5X32	
34-11-4	062501406	2	ナベコ5X14	SCREW, PAN M5X14	
41	200190001	5	ステツブル	STAPLE	
42	S44371001	1	ラツクカバー	RACK COVER	
43	062401006	4	ナベコ4X10	SCREW, PAN M4X10	
44	025040236	4	ヒラザガネチユウ4	WASHER, PLAIN M 4	
45	021400216	4	2シユナツト4	NUT, 2 M4	
46	025040236	4	ヒラザガネチユウ4	WASHER, PLAIN M 4	
50	144226001	1	トウブカバー	HEAD COVER	
<コントロールボックス取付用>				<For setting the Control box>	
51	146256001	4	クツシヨンカナグ	CUSHION COLLAR	
52	146255000	4	クツシヨン	CUSHION	
53	S00617000	4	ボウシンゴムカラー	RUBBER COLLAR	
54	133740006	4	カクネボルト5X70	BOLT, M6X70	
55	021060106	8	1シユナツト6	NUT, 1 M6	
56	025060336	4	ヒラザガネダイ6	WASHER, PLAIN L 6	
<電源SW取付用>				<For setting the Power switch>	
57	032461606	2	+マルモクネジ4.5X16	WOOD SCREW, ROUND M4.5X16	
58	S42882001	1	ヒンジオサエ	HINGE PRESSER	
59	018405032	2	アナボルト4X50	BOLT, SOCKET M4X50	
60	021400102	2	ナツト1シユ4	NUT, 1 M4	
61	S07783001	1	6カクボウスバナ1.5	HEXAGONAL WRENCH, 1.5	
71	S43273000	1	3.5メデア2HD	3.5 MEDIA, 2HD	
72	S09989000	1	フロツピーケース	FLOPPY CASE	
73	S42658000	1	3.5インデツクスラベル	INDEX LABEL, 3.5FD	
74	S43832001	1	テンシヨンプーリオオクミ	TENSION PULLEY SET	
74-1	S43676001	1	テンシヨンプーリクミ	TENSION PULLEY ASSY	
74-1-1	048320242	1	トメワアナヨウC32	RETAINING RING, INTERNAL C32	
74-1-2	141860001	1	シメネジ6.35	SCREW, SM6.35	

From the library of: Diamond Needle Corp

151-V26-910

◎ 付属品の明細は変更することがあります。

◎ The details of included accessories are subject to change.

◎ Änderungen in der Aufstellung der Mitgelieferten Zubehöre sind vorbehalten.

◎ Les détails des accessoires inclus sont sujets à des changements.

◎ Los detalles de accesorios incluidos pueden variar.

Z. 付属品関係 / Accessories / Zubehör / Accessoires / Accesorios

/ Lista d'epiezas de calibradores

Gal. 1. 一覧部品表 / List of parts of calibrators

REF.NO.	CODE	Q'TY	ヒンメイ	NAME OF PARTS	RM
74-2	018081222	1	アナボルト8X12	BOLT, SOCKET M8X12	
74-3	025080232	1	ヒラザガネチユウ8	WASHER, PLAIN M 8	
74-4	028080242	1	バネザガネ2-8	WASHER, SPRING 2-8	
101	105343001	1	メガネレンチ8X9	WRENCH, 8X9	
102	S11243001	1	スタビードライバー	SCREW DRIVER, STUBBIES	
103	150332001	1	プラスドライバーNO.2	SCREW DRIVER, 2X100	
92	S42890001	1	"オプション部品" プログラマササエ	"OPTION PARTS" PROGRAMMER SUPPORT	
93	032422003	2	+マルモクネジ4.1X20	WOOD SCREW, ROUND M4.1X20	
94	0B1351606	2	+サラモク35X16	WOOD SCREW, FLAT M3.5X16	
XY	S42849001	1	<For Horizontal wiper> オサエアシXY	PRESSER FOOT, XY	
E	S10212101	1	<For Heavy-weight extension> ハリアナイタE	NEEDLE HOLE PLATE, E	
F	S10213001	1	<For Medium-weight nut> ハリアナイタF	NEEDLE HOLE PLATE, F	
A	S10211001	1	"オプション部品" ハリアナイタA	"OPTION PARTS" NEEDLE HOLE PLATE, A	
D	S29997001	1	ハリアナイタD	NEEDLE HOLE PLATE, D	
ED	S30925001	1	ハリアナイタED	NEEDLE HOLE PLATE, ED	
FD	S30926001	1	ハリアナイタFD	NEEDLE HOLE PLATE, FD	
H	S30450001	1	ハリアナイタH	NEEDLE HOLE PLATE, H	
L	S25127001	1	ハリアナイタL	NEEDLE HOLE PLATE, L	
M	S34348001	1	ハリアナイタM	NEEDLE HOLE PLATE, M	

From the library of: Diamond Needle Corp

151-V26-910

- ◎ 付属品の明細は変更することがあります。
- ◎ The details of included accessories are subject to change.
- ◎ Änderungen in der Aufstellung der Mitgelieferten Zubehöre sind vorbehalten.
- ◎ Les détails des accessoires inclus sont sujets à des changements.
- ◎ Los detalles des accesorios incluidos pueden variar.

151-V26

押工足 / Presser foot

Ref.No.A	※	Ref.No.B	Ref.No.C	Ref.No.D

針穴板 / Needle hole plate

Ref.No.A	Ref.No.D	Ref.No.E	※	Ref.No.ED	Ref.No.F	※

- ◎ ※印の部品は、標準部品です。
- ◎ The ※ symbol is for Standard parts.
- ◎ Mit dem Zeichen ※ Standardteile bezeichnet.
- ◎ Le symbol ※ correspond aux pi ces normales.
- ◎ El asterisco ※ es para piezas normales.

From the library of: Diamond Needle Corp

Ga1. ゲージ部品一覧表 / Gauge parts List / Lehrenliste / Liste des Pièces decartment / Lista d'ePiezas de calibradores

REF.NO.	CODE	Q'TY	ヒンメイ	NAME OF PARTS	RM
A	S42843001	1	オサエアシA	PRESSER FOOT, A	※
B	S42844001	1	オサエアシB	PRESSER FOOT, B	
C	S42845001	1	オサエアシC	PRESSER FOOT, C	
D	S42846001	1	オサエアシD	PRESSER FOOT, D	
E	S42847001	1	オサエアシE	PRESSER FOOT, E	
F	157237001	1	オサエアシF	PRESSER FOOT, F	
G	158592001	1	オサエアシG	PRESSER FOOT, G	
J	S42848001	1	オサエアシJ	PRESSET FOOT, J	
XY	S42849001	1	<横払イワイパー用> オサエアシXY	<For Horizontal wiper> PRESSER FOOT, XY	
E	S10212101	1	<厚物用> ハリアナイタE ø2.6	<For Heavy-weight materials> NEEDLE HOLE PLATE, E ø2.6	※
F	S10213001	1	<中厚物用> ハリアナイタF ø2.2	<For Medium-weight materials> NEEDLE HOLE PLATE, F ø2.2	※
A	S10211001	1	" オプション部品 " ハリアナイタA ø1.6	" OPTION PARTS " NEEDLE HOLE PLATE, A ø1.6	
D	S29997001	1	ハリアナイタD ø2.6	NEEDLE HOLE PLATE, D ø2.6	
ED	S30925001	1	ハリアナイタED ø3.4	NEEDLE HOLE PLATE, ED ø3.4	
FD	S30926001	1	ハリアナイタFD ø2.2	NEEDLE HOLE PLATE, FD ø2.2	
H	S30450001	1	ハリアナイタH ø2.6	NEEDLE HOLE PLATE, H ø2.6	
L	S25127001	1	ハリアナイタL ø3.3	NEEDLE HOLE PLATE, L ø3.3	
M	S34348001	1	ハリアナイタM ø4.0	NEEDLE HOLE PLATE, M ø4.0	

From the library of: Diamond Needle Corp

151-V26

- ◎ ※印の部品は、標準部品です。
- ◎ The ※ symbol is for Standard parts.
- ◎ Mit dem Zeichen ※ Standardteile bezeichnet.
- ◎ Le symbol ※ correspond aux pièces normales.
- ◎ El asterisco ※ es para piezas normales.

< 中押工反転装置用 / For Inner clamping device >

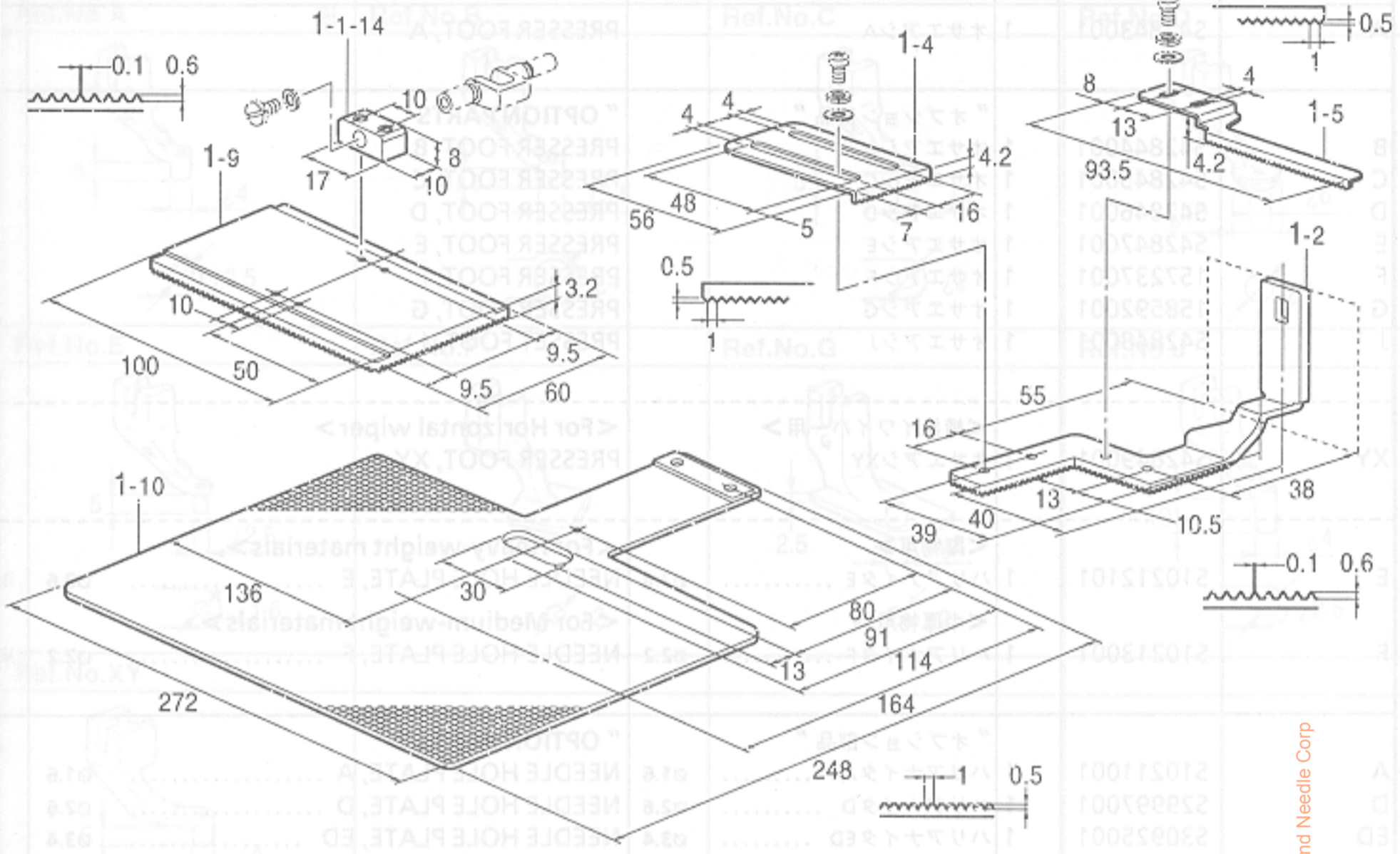

" 補給用部品 / For Supply parts "

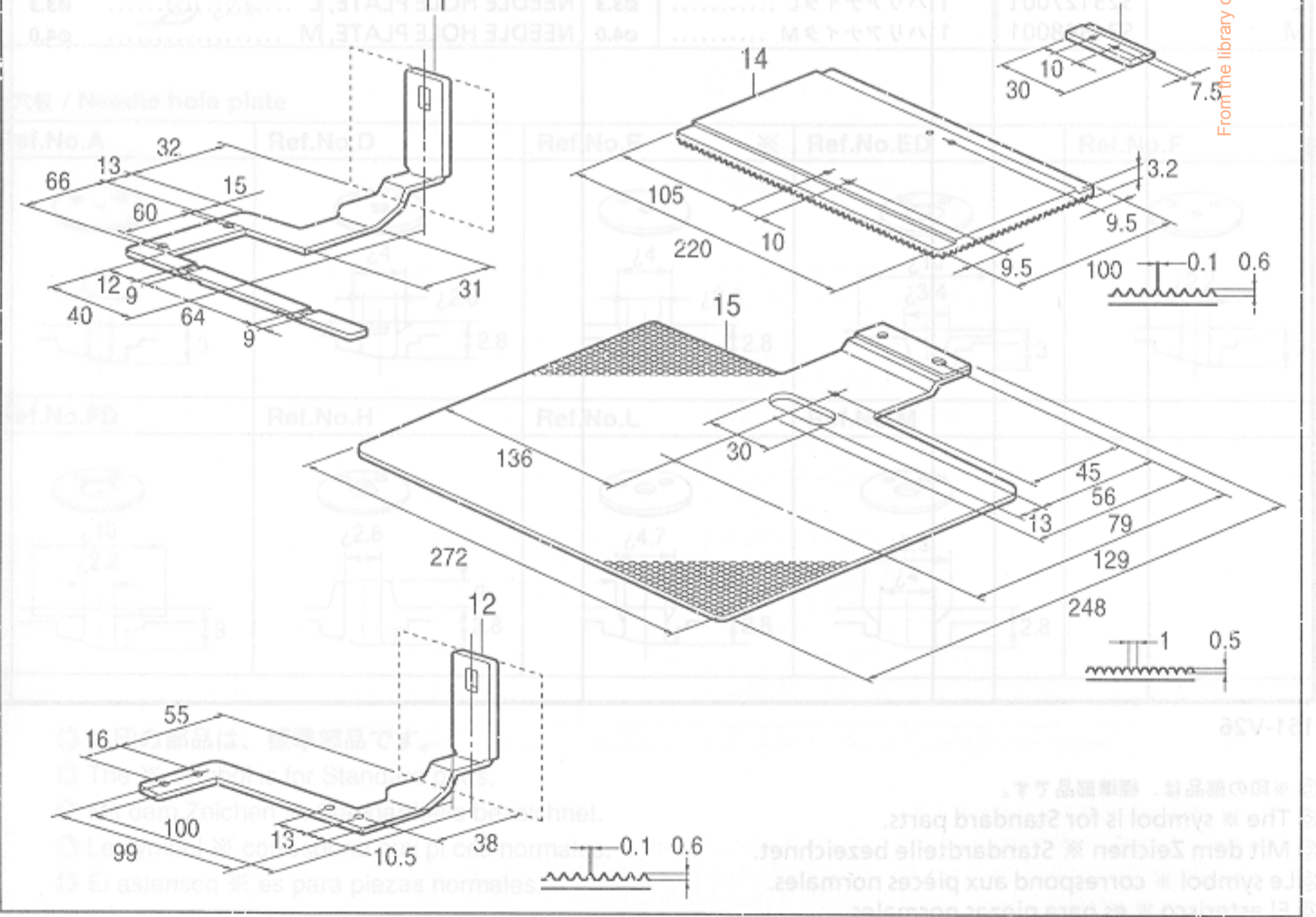

From the library of: Diamond Needle Corp

Ga2 . ゲージ部品一覧表 / Gauge parts List / Lehrenliste / Liste des Pièces decartment / Lista d'ePiezas de calibradores

REF.NO.	CODE	Q'TY	ヒンメイ	NAME OF PARTS	RM
1-1-14	154237001	1	<中押エ反転装置用> オサエイタホルダL	<For inner clamping device> WORK CLAMP PLATE HOLDER, L	※
1-2	S44425001	1	ソトオサエアシ326E-1	OUTER WORK CLAMP, 326E-1	※
1-4	154252001	1	イチギメイタL	POSITIONING PLATE, L	※
1-5	154253001	1	イチギメイタR	POSITIONING PLATE, R	※
1-9	154256101	1	オサエイタブランクA	WORK CLAMP PLATE BLANK, A	※
1-10	S51075001	1	オクリイタブランクLH ... t=1.2	FEED PLATE BLANK, H 326L t=1.2	※
11	S44426001	1	" 補給用部品 " ソトオサエアシ326E-2	" For Supply parts " OUTER WORK CLAMP, 326E-2	
12	S51076001	1	ソトオサエアシ326L-3	OUTER WORK CLAMP, 326L-3	
13	S10542001	1	ナカオサエLL	INNER CLAMP, LL	
14	S51077001	1	オサエイタブランクA326L	WORK CLAMP BLANK, A 326L	
15	S51078001	1	OTオクリイタブランクLH t=1.2	OT-FEED PLATE BLANK, H 326L t=1.2	

151-V26-943

- ◎ ※印の部品は、標準部品です。
- ◎ The ※ symbol is for Standard parts.
- ◎ Mit dem Zeichen ※ Standardteile bezeichnet.
- ◎ Le symbol ※ correspond aux pièces normales.
- ◎ El asterisco ※ es para piezas normales.

From the library of: Diamond Needle Corp

Wa. 警告ラベル / Warning labels / Warnschilder / Etiquettes d'avertissement
/ Etiquetas de advertencia

警告ラベル / Warning labels	品名 / Name of Parts	Size(mm)	Code
	電撃ラベル・和	40X64	S38353-101
	Label, elec. shock 4 lang.	35X118	S38352-101
	操作注意ラベル・BAS和	52X84	S38357-002
	Label, operation (BAS) Eng.	52X84	S38571-002
	PEマーク Mark, PE	7.5X12.5	S37059-001
	アースマーク Mark, grounding	φ 12	S37060-001

From the library of: Diamond Needle Corp

151-V26-050

索引 / INDEX / VERZEICHNIS
/ INDEX / INDICE

CODE	REF.NO.	Page
S00480000	P - 41	48
S00554000	M - 1-18	40
S00617000	Z - 53	73
S00705001	J - 47	34
S01005000	Z - 34-4-4	73
S02269001	B - 20	6
S02354001	J - 23	32
S02429101	E - 14-1-2	22
S02438001	G - 25-1	28
S02439001	G - 25-3	28
S02445001	A - 31	2
S02617001	AA1- 2-1-7	66
S02652001	J - 6	32
S02654001	J - 7-1	32
S02657101	AA1- 2-6	66
S02672002	K - 21	36
S02677001	K - 23	36
S02678001	K - 25	36
S02680001	AA2- 3-1-13	68
S02739000	U1 - 1-9	56
S02740000	U1 - 1-8	56
S02747101	Z - 34-4-5	73
S02763302	Z - 34	72
S02777001	Z - 34-4	72
S02778002	Z - 34-9	73
S02786002	Z - 34-10	73
S02787002	Z - 34-10-1	73
S02907000	S - 1-8	52
S03677001	D - 66	20
S03704002	E - 13	22
S03803000	Y - 1-13	64
S04897000	AA2- 4-4	68
	AA2- 5-4	68
S05223001	U1 - 1-2-1-6	56
	U1 - 1-2-2-6	56
S05665001	Y - 1-1-9	64
S05670002	N - 12-1	44
	N - 12-1	46
S06706001	Z - 15	72
S07333001	F - 2	26
S07456000	F - 3	26
S07783001	Z - 61	73
S07818009	P - 23	48
S08030000	M - 1-29-5	40
	Z - 24	72
S08140000	AA2- 5-3	68
S09043000	F - 31	26
	F - 45	26
S09216002	U1 - 1-2-1-1	56
S09217102	U1 - 1-2-1-2	56
S09221002	U1 - 1-2-2-1	56
S09222102	U1 - 1-2-2-2	56
S09224002	N - 35	46
	U1 - 1-2-7	56
S09225001	N - 36	46
	U1 - 1-2-8	56
S09226001	N - 39	46
	U1 - 1-2-11	56
S09228000	N - 1-1-4	44
	N - 1-2-4	44
S09312001	U1 - 1-2-1-5	56
	U1 - 1-2-2-5	56
S09318101	N - 1-1-2	44

CODE	REF.NO.	Page
S09318101	N - 1-2-2	44
S09393002	N - 12-1	44
	N - 12-1	46
S09639009	U1 - 1-2-1	56
S09640009	U1 - 1-2-2	56
S09989000	Z - 72	73
S10030002	A - 24	2
S10065001	C1 - 10	10
S10078001	C3 - 121	14
S10091101	C3 - 65	14
S10111101	D - 57	20
S10112001	D - 58	20
S10113201	D - 59	20
S10162201	F - 15	26
S10174000	H - 1-15	30
S10189001	J - 18	32
S10195001	J - 30	32
S10202101	J - 41	32
S10204101	J - 44	32
S10205001	J - 45-1	32
S10208001	J - 46	32
	Z - 18	72
S10208002	J - 46	32
	Z - 18	72
S10208003	J - 46	34
	Z - 18	72
S10209101	J - 48	34
S10210201	J - 49-1	34
S10211001	J - 53-1	34
	Ga1 - A	76
S10212101	J - 53-3	34
	Ga1 - E	76
S10213001	J - 53-5	34
	Ga1 - F	76
S10214109	K - 5-1	36
	AA2- 3-1-3	68
S10215109	K - 8-1	36
S10217001	K - 13	36
S10219001	L - 1	38
S10221001	L - 7	38
S10229101	L - 15	38
S10230000	L - 21	38
S10231001	L - 23	38
S10232001	L - 27	38
S10239001	L - 30	38
S10243000	N - 29	44
	P - 9	48
S10352101	C3 - 136	14
S10371001	D - 61	20
S10372100	D - 62	20
S10408000	S - 8	52
S10470101	K - 17	36
S10478000	F - 10	26
S10542001	Y - 13	64
	Ga2 - 13	78
S10661109	U1 - 1-2-1-8	56
	U1 - 1-2-2-8	56
S11182009	G - 13	28
S11243001	Z - 102	74
S11884001	AA1- 2-1-5	66
S12104000	AA2- 5-2	68
S12150000	AA3- 2-1-3	70
S12212000	N - 10	44

CODE	REF.NO.	Page
S12404000	N - 1-1-5-2-1	44
	N - 1-2-5-2-1	44
S12441001	G - 32	28
S12634009	Y - 1-1-1	64
S12635009	Y - 1-1-2	64
S12637009	Y - 1-1-17	64
S12638009	Y - 1-1-6	64
S12639001	Y - 1-1-18	64
S12640009	Y - 1-1-20	64
S12642009	Y - 1-1-19	64
S12668001	K - 33	36
S12699000	G - 11	28
S13007001	C5 - 157	18
S13385001	K - 30	36
S13399001	D - 65	20
S14386000	C5 - 161	18
S14387000	C5 - 161	18
S14388101	C5 - 160	18
S14389000	C5 - 163	18
S14390000	C5 - 163	18
S14392201	C5 - 159	18
S14841001	C4 - 155	16
	C5 - 155	18
S15031008	AA2- 3-3	68
	AA2- 4-2	68
	AA3- 2-4	70
S15158009	U1 - 1-17	56
S15662992	E - 22-1	22
S15663991	E - 22-1	22
S15665001	E - 25	22
	Z - 16	72
S15666001	E - 25	24
S15667001	E - 24-1-3	22
	E - 24-1-3	24
	E - 24-2-3	24
S15902401	E - 24-1	22
S15903401	E - 24-1	24
S16074101	E - 24-1-1	22
S16075101	E - 24-1-1	24
S16492101	E - 24-1-2	22
	E - 24-1-2	24
	E - 24-2-2	24
S16568000	M - 1-8	40
S17803001	A - 34	2
S17813001	C1 - 1-14	10
S17815000	C1 - 2	10
S17868001	C2 - 32	12
S17871101	D - 46	20
S17885101	C3 - 106	14
S17886100	C3 - 110	14
S17887001	C3 - 111	14
S17888001	C3 - 112	14
S17890001	C3 - 122	14
S17901000	F - 47	26
S17942000	AA2- 3-1-1	68
S18027101	AA2- 4-1	68
S18032001	AA1- 1-1-1	66
S18037009	AA1- 1-1-12	66
S18093100	F - 18	26
	F - 25	26
	Z - 4-4	72
S18415101	N - 1-1-5-1-3	44
	N - 1-2-5-1-3	44

CODE	REF.NO.	Page
S18415101	Y - 1-1-25	64
	Y - 1-11-8	64
	AA2- 3-1-4	68
	AA2- 3-2-3	68
	AA2- 4-3-4	68
	AA3- 2-2-4	70
	AA3- 6-4	70
S18539000	C1 - 1-5	10
S18633109	U1 - 37	56
	U2 - 37	58
S18636101	C1 - 1-23	10
S18707149	Z - 13	72
S19736001	A - 113	2
	A - 116	2
S20137001	U1 - 40	56
	U2 - 40	58
S20164009	A - 33	2
S20289101	V - 3-3	60
	V - 4-1	60
S20293101	V - 3-4	60
	V - 5-1	60
S20822101	V - 4	60
S20823101	V - 5	60
S21527001	F - 14	26
S21775001	C1 - 1-18	10
S21798001	Z - 34-8	73
S21875001	K - 32	36
S23445001	C2 - 33	12
S23446000	C2 - 34	12
S23836001	J - 7	32
S23880000	N - 1-1-10	44
	N - 1-2-9	44
S24511007	B - 24	8
S25100000	N - 26	46
S25127001	J - 53-8	34
	Ga1 - L	76
S25456001	K - 3	36
	K - 11	36
S25634101	S - 5	52
S28741000	Y - 1-14	64
S29023000	S - 1-2-1	52
S29468100	AA1- 2-1-4	66
S29710000	N - 1-2-3	44
S29997001	J - 53-2	34
	Ga1 - D	76
S30033001	J - 21-3	32
S30128001	J - 49-2	34
S30260002	S - 1-2-2	52
S30450001	J - 53-7	34
	Ga1 - H	76
S30925001	J - 53-4	34
	Ga1 - ED	76
S30926001	J - 53-6	34
	Ga1 - FD	76
S30950000	C1 - 1-4	10
S30951001	C1 - 1-9	10
S31012001	D - 55	20
S31013001	D - 56	20
S31551009	N - 1-1-1	44
	N - 1-2-1	44
S31554009	AA3 - 6-5	70
S31570209	Y - 1-11-1	64
S31612001	J - 45-4	34

CODE	REF.NO.	Page
S31674000	P - 32	48
S31760000	M - 1-19	40
S31776109	AA2- 3-1-8	68
S31777001	AA2- 3-1-2	68
S31778000	AA2- 3-1-6	68
S31779001	AA2- 3-1-7	68
S34348001	J - 53-9	34
	Ga1 - M	76
S34413000	M - 1-28	40
S34533001	AA3- 2-1-4	70
S34534001	AA3- 2-1-5	70
S34536001	AA3- 2-1-12	70
S34705000	AA3- 2-1-1	70
S34986000	F - 11	26
S35183000	C1 - 1-2	10
S36008009	S - 1-18	52
S36260000	T - 1-9-2	54
	T - 2-5-2	54
S37037001	Z - 34-11-3	73
S37038001	Z - 34-11-2	73
S37057001	P - 36	48
S37059001	Mi - 1-25	40
	Wa	79
S37060001	M - 1-26	40
	Wa	79
S37147109	K - 5-2	36
S37148109	K - 8-2	36
S37806109	K - 8-3	36
S37920009	A - 27	2
S37927000	B - 17	6
S37928019	B - 24	8
S37929009	B - 24	8
S37929016	B - 24	8
S37973201	D - 71	20
S37978151	E - 5	22
S37979101	E - 8	22
S37981051	E - 9	22
S37983001	F - 6	26
S37984000	F - 17	26
	F - 34	26
S37987001	F - 28	26
S37988000	F - 29	26
S37990309	H - 1	30
S37991109	H - 1-1	30
S37992100	H - 1-2	30
S37993000	H - 1-3	30
S37994001	H - 1-5	30
S37995101	H - 1-6	30
S37996001	H - 1-8	30
S37997001	H - 1-11	30
S37998001	H - 1-16	30
S38001001	J - 1	32
S38002101	J - 3	32
S38003001	J - 8	32
S38004002	J - 10	32
S38004003	J - 10	32
S38004004	J - 10	32
S38005001	J - 15	32
S38006001	J - 21	32
S38007001	J - 21-1	32
S38010001	J - 29	32
S38011001	J - 34	32
S38035109	B - 8	6

CODE	REF.NO.	Page
S38039109	Z - 4	72
S38040109	Z - 4-1	72
S38041000	U1 - 1-16	56
	U2 - 27	58
S38043009	Z - 20	72
S38059000	T - 1-24	54
	T - 2-20	54
S38060000	T - 1-23	54
	T - 2-19	54
S38080001	Q - 4	50
S38082001	Q - 5	50
S38094100	M - 1-4	40
S38104000	S - 1-2-4	52
S38107100	M - 1-12	40
S38108000	M - 1-13	40
S38109100	M - 1-14	40
S38110000	M - 1-15	40
S38112001	M - 2-1	40
S38114000	M - 2-2	41
S38115000	M - 2-2-1	41
S38117000	M - 2-3	41
S38120000	M - 2-5	41
S38122200	M - 1-9	40
S38123000	M - 3-1	41
S38148000	P - 26	48
S38155000	R - 1-3	50
S38164000	R - 1-4	50
S38166000	T - 1-1	54
	T - 2-1	54
S38167001	T - 1-2	54
S38168001	T - 1-5	54
S38170001	T - 1-8	54
	T - 2-4	54
S38174000	T - 1-12	54
	T - 2-8	54
S38175001	T - 1-13	54
	T - 2-9	54
S38176101	T - 1-14	54
	T - 2-10	54
S38177001	T - 1-18	54
	T - 2-14	54
S38180000	T - 1-22	54
	T - 2-18	54
S38200000	M - 1-29-2	40
S38201000	M - 1-29-4	40
S38352101	M - 20	40
	Wa	79
S38353101	M - 21	40
	Wa	79
S38357002	Wa	79
S38571002	Wa	79
S38648001	Z - 34-4-2	72
S40616001	M - 40-1	41
S40621000	M - 50	41
	W - 2	62
S40622000	M - 51	41
S40623000	M - 42	41
S40624000	M - 40-2	41
S40628000	N - 1-1-3	44
S40629000	N - 1-1-9	44
S40635001	M - 40	41
S40640001	Z - 34-5	73
S40641001	Z - 34-11	73

From the library of: Diamond Needle Corp

CODE	REF.NO.	Page
S40764000	M - 52	41
S40837001	E - 14-2	22
	X - 1-1	62
S40838001	E - 14-2-1	22
S40839001	E - 14-2-2	22
	X - 1-1-1	62
S40840001	E - 19-2	22
	X - 1-2	62
S40841001	X - 1-3	62
S40841101	E - 21-2	24
S40842991	E - 22-2	24
	X - 1-4	62
S40843001	E - 24-2	24
	X - 1-5	62
S40845001	E - 24-2-1	24
	X - 1-5-1	62
S40846001	J - 45-3	34
	X - 1-6	62
S40886001	E - 14-1-1	22
S40934101	J - 45-2	34
S41202051	P - 24	48
S41205001	K - 2	36
S41206001	K - 1	36
S41207000	K - 4	36
S41222101	G - 25-2	28
S42258000	T - 1-9-1	54
S42259000	T - 1-9	54
S42260000	M - 1-10	40
S42653000	M - 1-27	40
	M - 53	41
	S - 1-15	52
S42658000	Z - 73	73
S42750109	A - 20	2
S42751009	A - 20-1	2
S42752000	A - 20-2	2
S42754001	B - 3	6
S42756001	B - 14-1-6	6
	B - 14-2-6	6
S42758001	A - 38	2
S42787001	C2 - 75-1	12
S42795101	C3 - 125	14
S42796001	C3 - 127	14
S42798001	C2 - 75-3	12
S42800001	C2 - 75-5	12
S42818101	E - 14-1	22
S42827000	F - 23	26
S42830001	B - 1	6
S42836001	D - 39	20
S42837001	D - 39-1	20
S42839101	D - 48	20
S42840101	D - 51	20
S42842101	T - 1	54
S42843001	D - 64-1	20
	Ga1 - A	76
S42844001	D - 64-2	20
	Ga1 - B	76
S42845001	D - 64-3	20
	Ga1 - C	76
S42846001	D - 64-4	20
	Ga1 - D	76
S42847001	D - 64-5	20
	Ga1 - E	76
S42848001	D - 64-8	20

CODE	REF.NO.	Page
S42848001	Ga1 - J	76
S42849001	D - 64-9	20
	Ga1 - XY	76
S42850409	U1 - 1	56
S42851301	U1 - 1-1	56
S42856001	J - 40	32
S42858001	K - 12	36
S42859001	K - 27	36
S42864101	K - 28	36
S42867001	T - 1-6	54
	T - 2-2	54
S42868001	L - 8	38
S42870101	L - 11	38
S42871101	L - 12	38
S42873101	L - 14	38
S42874001	L - 17	38
S42880001	D - 70	20
S42882001	Z - 58	73
S42884001	C2 - 75-2	12
S42886101	J - 25	32
S42887101	J - 25-1	32
S42890001	Z - 92	74
S43169009	M - 1	40
S43170009	M - 1-1	40
S43171009	M - 1-2	40
S43172009	M - 1-3	40
S43173001	M - 1-29	40
S43177000	M - 1-29-1	40
S43183100	M - 1-11	40
S43186000	M - 1-17	40
S43188000	M - 2-6	41
S43190000	M - 10	40
S43191000	M - 11	40
S43196000	P - 3	48
S43197000	P - 4	48
S43201000	M - 3-4	41
S43202000	P - 21	48
S43203000	P - 35-1	48
	AA2- 3-1-10	68
S43204000	P - 35-2	48
S43206000	P - 20	48
S43210001	R - 1	50
S43220209	S - 1	52
S43223009	S - 1-1	52
S43224000	S - 1-9	52
S43225000	S - 1-10	52
S43226000	S - 1-3	52
S43227200	S - 1-4	52
S43228000	S - 1-13	52
S43229001	S - 1-2	52
S43236009	S - 2	52
S43237000	S - 1-7	52
S43240009	M - H-9	42
S43241009	M - H-1	42
S43242009	M - H-2	42
S43243009	M - H-3	42
S43244009	M - H-6	42
S43245009	M - H-4	42
S43246009	M - H-5	42
S43247009	M - H-7	42
S43248009	M - H-8	42
S43249001	W - 1	62
S43250000	W - 1-1	62

CODE	REF.NO.	Page
S43251000	W - 1-2	62
S43252000	W - 1-3	62
S43253000	W - 1-4	62
S43254000	W - 1-5	62
S43255000	W - 1-7	62
S43256000	W - 1-8	62
S43257000	W - 1-9	62
S43259001	W - 1-18	62
S43267000	W - 1-14	62
S43268000	W - 1-15	62
S43269000	W - 1-19	62
S43270000	W - 1-16	62
S43271000	W - 1-11	62
S43272000	W - 1-12	62
S43273000	Z - 71	73
S43274000	M - 1-16	40
S43275000	M - 1-20	40
S43276000	M - 1-21	40
S43277000	M - 1-22	40
S43278000	M - 31	41
	N - 12-2	46
	N - 12-2	46
S43279200	AA1- 2-1-1	66
S43309000	M - 24	40
S43369000	M - 2	41
S43370000	M - 3	41
S43671109	U1 - 2	56
S43672109	U1 - 2-3	56
S43673000	F - 35	26
S43674000	S - 4	52
S43675000	S - 4	52
S43676001	Z - 74-1	73
S43678009	N - 1	44
S43679001	N - 1-1-5	44
	N - 1-2-5	44
S43680001	N - 1-1-5-1	44
	N - 1-2-5-1	44
S43682000	N - 1-1-5-2	44
	N - 1-2-5-2	44
S43683001	N - 1-1-5-1-2	44
	N - 1-2-5-1-2	44
	N - 27	46
	Y - 1-11-6	64
	AA2- 3-2-1	68
	AA2- 4-3-1	68
	AA3- 2-2-1	70
	AA3- 6-1	70
S43684001	N - 1-1-5-1-1	44
	N - 1-2-5-1-1	44
S43686000	N - 1-1-11	44
S43687001	N - 8-1	44
S43687002	N - 8-2	44
S43688001	N - 9-1	44
S43688002	N - 9-2	44
S43689001	B - 14-1-5	6
	B - 14-2-5	6
S43693000	D - 40	20
S43694009	N - 1-2	44
S43696000	N - 28	46
	Y - 1-11-7	64
	AA2- 4-3-2	68
	AA3- 2-2-2	70
	AA3- 6-2	70

CODE	REF.NO.	Page
S43832001	Z - 74	73
S43833109	AA1- 1	66
S43834109	AA1- 1-1	66
S43835100	AA1- 1-1-11	66
S43836301	AA1- 2	66
S43837001	AA3- 2	70
S43838001	AA3- 2-1	70
S43839005	AA3- 2-2	70
S43839008	AA2- 4-3	68
S43841009	AA2- 3	68
S43842009	AA2- 3-1	68
S43843009	AA2- 3-1-11	68
S43844001	AA2- 3-2	68
S43846009	AA2- 4	68
S43847101	AA3- 6	70
S43977201	AA1- 2-1	66
S43981000	W - 1-17	62
S43982001	B - 14-1-1	6
	B - 14-2-1	6
S43984001	B - 14-1	6
S43985001	B - 14-2	6
S44309109	A - 13	2
S44313001	A - 15	2
S44317009	A - 101	2
S44320001	A - 111	2
S44321001	A - 114	2
S44322101	A - 121	4
S44326001	C1 - 1-6	10
S44327001	C1 - 1-12	10
S44328001	C1 - 1-13	10
S44329001	C1 - 1-15	10
S44369009	Z - 1	72
S44370009	Z - 1-1	72
S44371001	Z - 42	73
S44372000	P - 2	48
S44380001	J - 43	32
S44381001	C1 - 12-5	10
S44382001	C3 - 90	14
S44383000	P - 1	48
S44387009	A - 117	2
S44411001	C5 - 156	18
S44412001	AA2- 5-1	68
S44413001	C5 - 154-2	18
S44414001	V - 3	60
S44415001	V - 3-1	60
	V - 6-1	60
S44417001	V - 3-2	60
	V - 6-2	60
S44420009	Y - 1-1	64
S44421001	Y - 1-1-3	64
S44422001	Y - 1-1-4	64
S44424001	Y - 1-1-26	64
S44425001	Y - 1-2	64
	Ga2 - 1-2	78
S44426001	Y - 11	64
	Ga2 - 11	78
S44433201	C1 - 12	10
S44434001	C1 - 12-2	10
S44436000	C1 - 12-4	10
S44437201	C1 - 12-1	10
S44443001	C2 - 30	12
S44445001	C3 - 67	14
S44446001	C3 - 70	14

CODE	REF.NO.	Page
S44447001	C2 - 73	12
S44450001	AA2- 5	68
S44451001	C2 - 75-4	12
S44453001	C2 - 75-6	12
S44455001	C2 - 91	12
S44456000	C3 - 101	14
S44457000	C3 - 102	14
S44458001	C3 - 103	14
S44459001	C3 - 105	14
S44483001	A - 22-1	2
S44485001	A - 22-2	2
S44487001	A - 22-6	2
S44494001	A - 22	2
S44606001	A - 105	2
S44624000	C3 - 120	14
S44629001	A - 920	4
S44664000	P - 6	48
S44665001	P - 6-1	48
S44665002	P - 6-2	48
S44669001	C2 - 41	12
S44745009	Y - 1-11	64
S44746000	N - 28-1	46
	Y - 1-11-7-1	64
	AA2- 4-3-2-1	68
	AA3- 2-2-2-1	70
	AA3- 6-2-1	70
S44748001	Y - 1-11-2	64
	AA2- 3-2-2	68
	AA2- 4-3-3	68
	AA3- 2-2-3	70
S44749001	AA3- 6-3	70
S44750000	N - 28-2	46
	Y - 1-11-7-2	64
	AA2- 3-2-6	68
	AA2- 4-3-2-2	68
	AA3- 2-2-2-2	70
	AA3- 6-2-2	70
S44757001	C3 - 68	14
S44759000	AA2- 3-2-4	68
S44760000	AA2- 3-2-5	68
S44795001	X - 1	62
S44805101	T - 2	54
S44806000	T - 2-5	54
S44807000	T - 2-5-1	54
S44924001	C3 - 126	14
S45147001	B - 2	6
S45252000	Y - 1-11-9	64
S45253000	Y - 1-11-9-1	64
S45254000	Y - 1-11-9-2	64
S45724009	Z - 19	72
S46255000	N - 13	46
S46405000	F - 24	26
S46460000	U1 - 1-15	56
	U2 - 26	58
S46476001	P - 7	48
S47112000	C2 - 26	12
S47592000	M - 2-4	41
S47594000	M - 2-7	41
S48534009	A - 16	2
S48537009	A - 17	2
S48539001	A - 29	2
S48540109	A - 103	2
S48555000	C4 - 152	16

CODE	REF.NO.	Page
S48666001	Q - 1	50
S49419001	C1 - 1-22	10
S49443000	T - 3	54
S50661009	N - 12	46
S50662009	N - 12	46
S51027001	C1 - 1	10
S51028000	C1 - 1-1	10
S51029001	C1 - 3	10
S51030001	C1 - 6	10
S51031001	C1 - 7	10
S51032000	C2 - 16	12
S51033001	C2 - 17	12
S51034001	C2 - 23	12
S51035001	C2 - 28	12
S51036001	C2 - 38	12
S51037001	C2 - 140-1	12
S51038001	C2 - 140-2	12
S51039000	C3 - 87	14
S51040001	C3 - 130	14
S51041001	C3 - 133	14
S51042001	C2 - 5	12
S51043001	C4 - 138	16
S51045001	C4 - 150-1	16
S51046001	C4 - 150-2	16
S51047001	C4 - 150-3	16
S51048001	C5 - 151-1	18
S51049001	C5 - 151-2	18
S51050001	C5 - 151-3	18
S51051001	C4 - 153-1	16
S51052001	C4 - 153-2	16
S51053001	C4 - 153-1	16
S51054001	C4 - 153-2	16
S51055001	C4 - 153-1	16
S51056001	C4 - 153-2	16
S51057001	C4 - 153-1	16
S51058001	C4 - 153-2	16
S51059001	C4 - 153-3	16
S51060001	C4 - 153-4	16
S51061001	C4 - 153-3	16
S51062001	C4 - 153-4	16
S51063001	C4 - 153-3	16
S51064001	C4 - 153-4	16
S51065001	C4 - 153-3	16
S51066001	C4 - 153-4	16
S51067001	C5 - 189-1	18
S51069001	C5 - 189-1	18
S51071001	C5 - 189-1	18
S51073009	Y - 1	64
S51075001	Y - 1-10	64
	Ga2 - 1-10	78
S51076001	Y - 12	64
	Ga2 - 12	78
S51077001	Y - 14	64
	Ga2 - 14	78
S51078001	Y - 15	64
	Ga2 - 15	78
S51804001	C5 - 154-1	18
U32744000	R - 1-5	50
U34870001	S - 1-2-3	52
U38337000	R - 1-1	50
U38338000	R - 1-2	50
0A4300605	S - 1-6	52
	S - 1-11	52

From the library of: Diamond Needle Corp

CODE	REF.NO.	Page
0A4400605	M -41	41
0A5400805	S -1-5	52
0A5400806	M -1-6	40
0A5401006	M -1-7	40
	P -10	48
	P -12	48
	P -14	48
	P -27	48
	P -38	48
0A5401605	M -43	41
0A5403006	M -1-5	40
0B1351606	Z -94	74
002300403	T -1-15	54
	T -2-11	54
002300603	S -1-14	52
002301203	P -8	48
004400603	T -1-7	54
	T -2-3	54
004400814	C1 -13	10
008400604	K -8-4	36
	M -1-23	40
	S -1-17	52
011679312	C1 -1-3	10
014679320	H -1-7	30
014680422	J -42	32
	C1 -1-18-2	10
	C2 -27	12
014680622	E -3	22
	G -28	28
	H -1-9	30
	J -7-2	32
	L -24	38
014710522	K -31	36
	C3 -113	14
014760622	B -9	6
	D -39-2	20
	E -7	22
	E -10	22
	E -15	22
	J -33	32
	Z -10	72
	C1 -1-19	10
	C1 -1-24	10
	C2 -18	12
	C2 -31	12
	C2 -35	12
014770622	B -12	6
	B -12	6
	E -13-1	22
	J -2	32
	J -22	32
	C3 -100	14
	C3 -104	14
	C3 -107	14
014780622	B -4	6
	B -15	6
017081606	N -37	46
	U1 -1-2-1-3	56
	U1 -1-2-2-3	56
	U1 -1-2-4	56
	U1 -1-2-9	56
017082203	N -19	46
017501216	Y -1-1-23	64

CODE	REF.NO.	Page
017751412	D -47	20
017761412	C1 -14	10
017821813	AA3-2-3	70
017822212	L -25	38
018016122	C2 -29	12
018060822	L -19	38
018061036	M -4	40
018061422	L -2	38
018081222	Z -74-2	74
018081636	S -7	52
018082022	A -102	2
	A -104	2
018300836	Y -1-1-21	64
	Y -1-1-22	64
018301036	Y -1-1-8	64
018301236	Y -1-1-7	64
018302032	AA3-2-1-2	70
018400822	C2 -42	12
018400832	C1 -1-20	10
018401022	C2 -39	12
018401622	C1 -1-10	10
018401636	C3 -88	14
018405032	Z -59	73
018501222	A -107	2
	C2 -24	12
018501422	E -20	22
	L -22	38
	C3 -145	14
018501622	A -106	2
	P -15	48
	C3 -118	14
	C3 -119	14
	C3 -143	14
018680822	V -3-5	60
	V -4-2	60
	V -5-2	60
	C1 -12-3	10
	C1 -86	10
	C3 -123	14
018681022	J -11	32
	K -6	36
021060106	Z -55	73
	U1 -1-24	56
	U2 -36	58
021060206	P -30	48
021080106	N -23	46
021400102	Z -60	73
021400106	M -45	41
021400216	Z -45	73
021500103	N -5	44
021500106	S -9	52
	Z -34-8-3	73
	Z -34-11-1	73
021500216	Y -1-1-24	64
021660102	A -22-4	2
	K -36	36
021660306	C5 -158	18
021670202	K -34	36
021680202	H -1-24	30
021750102	D -45	20
022120306	U1 -1-2-1-7	56
	U1 -1-2-2-7	56
025030135	AA1-1-1-9	66

CODE	REF.NO.	Page
025030232	A -22-5	2
	N -1-1-8	44
	N -1-2-8	44
	Y -1-11-5	64
	AA1-2-1-3	66
025030236	T -1-17	54
	T -2-13	54
025040132	C1 -1-21	10
025040232	C2 -40	12
	C2 -43	12
	C3 -129	14
	U1 -42	56
	U2 -42	58
025040236	M -44	41
	Z -44	73
	Z -46	73
025050232	P -16	48
	C2 -25	12
	C3 -117	14
	C3 -144	14
025050236	S -6	52
	U1 -1-5	56
025060132	C1 -15	10
025060236	M -6	40
	T -1-4	54
025060336	Z -56	73
	U1 -1-22	56
	U2 -34	58
025080232	N -21	46
	Z -74-3	74
025080236	U1 -1-2-6	56
025080336	N -22	46
025350132	Y -1-1-15	64
025350332	A -32	2
	Y -1-7	64
025680132	Q -7	50
025680232	F -8	26
	H -1-27	30
	H -4	30
	J -39	32
	C1 -8	10
025750132	K -16	36
026120236	U1 -1-2-1-9	56
	U1 -1-2-2-9	56
028030242	N -1-1-7	44
	N -1-2-7	44
	Y -1-11-4	64
028030246	T -1-16	54
	T -2-12	54
028040246	C3 -89	14
028050242	P -17	48
028050246	Z -34-8-2	73
	U1 -1-6	56
028060242	L -3	38
028060246	M -5	40
	P -31	48
	U1 -1-23	56
	U2 -35	58
028080242	N -20	46
	Z -74-4	74
028080246	N -38	46
	U1 -1-2-1-4	56
	U1 -1-2-2-4	56

From the library of: Diamond Needle Corp

CODE	REF.NO.	Page
028080246	U1 - 1-2-5	56
	U1 - 1-2-10	56
028120246	U1 - 1-2-1-10	56
	U1 - 1-2-2-10	56
028350242	j - 21-6	32
	Y - 1-8	64
	AA1- 2-1-8	66
028680242	F - 9	26
032361306	U1 - 1-14	56
032422003	Z - 93	74
	U1 - 38	56
	U2 - 38	58
032461606	Z - 57	73
037200615	W - 1-10	62
037300615	W - 1-13	62
037300816	S - 1-12	52
037301015	W - 1-6	62
037301215	Z - 4-3	72
037521016	U1 - 1-4	56
039411215	U1 - 1-10	56
048020342	AA1- 1-1-10	66
048030342	K - 15	36
048040342	D - 63	20
	K - 20	36
	L - 16	38
	C1 - 1-8	10
048050342	H - 1-10	30
	C1 - 1-16	10
048050346	T - 1-19	54
	T - 2-15	54
048060142	T - 1-3	54
048060342	J - 32	32
	C3 - 109	14
	C3 - 116	14
048070342	J - 19	32
048080342	E - 18	22
	C2 - 36	12
048100142	H - 1-4	30
048150142	B - 7	6
048160242	C3 - 114	14
	C3 - 142	14
048220242	C2 - 37	12
048320242	Z - 74-1-1	73
052400606	T - 1-20	54
	T - 2-16	54
052501205	N - 2	44
060670512	F - 16	26
060670612	G - 6	28
	AA1- 2-1-9	66
	AA1- 2-3	66
060680512	K - 19	36
060680712	D - 72	20
	J - 4	32
061660806	A - 22-3	2
062300412	P - 29	48
062300612	P - 28	48
	AA1- 2-1-2	66
	AA1- 2-1-6	66
	AA2- 3-1-12	68
062301205	T - 1-10	54
	T - 2-6	54
062301616	AA1- 1-1-13	66
062302506	N - 1-1-6	44

CODE	REF.NO.	Page
062302506	N - 1-2-6	44
	Y - 1-11-3	64
062400612	A - 39	2
062400806	Q - 2	50
062400812	N - 30	44
	C3 - 128	14
062401006	Z - 3	72
	Z - 43	73
062404005	Y - 1-11-10	64
062501406	Z - 34-11-4	73
062660412	E - 14-1-3	22
	E - 14-2-3	22
062660712	E - 14-1-7	22
	E - 14-2-7	22
062670412	G - 31	28
062670512	A - 22-7	2
	F - 27	26
	F - 39	26
	F - 49	26
	Y - 1-6	64
	C2 - 75-7	12
062670612	A - 23	2
	G - 4	28
	G - 24	28
	L - 10	38
	L - 32	38
	AA2- 3-1-5	68
062670712	C2 - 76	12
062670812	AA2- 4-5	68
062671212	C2 - 77	12
062680512	H - 1-18	30
	K - 9	36
	K - 22	36
	C1 - 11	10
	AA2- 3-1-9	68
062680612	A - 18	2
	A - 28	2
	F - 7	26
	F - 30	26
062680712	B - 14-1-7	6
	B - 14-2-7	6
062680812	A - 119	4
	A - 120	4
	H - 3	30
	C3 - 66	14
	C3 - 69	14
062681212	A - 112	2
	A - 115	2
	D - 60	20
	H - 2	30
062681412	Q - 6	50
062710612	G - 2	28
062711012	A - 21	2
062711212	A - 14	2
062760812	L - 28	38
062761012	A - 122	4
	C3 - 71	14
062771012	L - 20	38
072630260	B - 6	6
081003670	E - 12	22
	E - 17	22
100022004	H - 1-26	30
100022005	J - 24	32

CODE	REF.NO.	Page
100032004	J - 51	34
100090004	E - 2	22
100136001	G - 20	28
	H - 1-20	30
100242003	B - 18	6
	Y - 1-1-16	64
100250001	B - 11	6
	B - 11	6
100360003	J - 54	34
100398001	G - 12	28
100402004	G - 17	28
100645003	K - 7	36
100659001	K - 35	36
100887001	Z - 30	72
101073001	U1 - 1-12	56
101121000	U1 - 1-13	56
101572101	Z - 28	72
101706001	B - 13-1	6
	E - 6-1	22
102630001	B - 16	6
103950003	G - 18	28
104450109	A - 4	2
	A - 10	2
	A - 43	2
	Z - 1-2	72
104525001	G - 14	28
	AA3- 2-6	70
104567001	F - 21	26
105073001	U1 - 1-17	56
	U2 - 28	58
105343001	Z - 101	74
106129002	j - 21-5	32
106147002	J - 14	32
	L - 26	38
106588003	J - 25-3	32
106629002	A - 19	2
	A - 30	2
	A - 118	4
	J - 52	34
	C3 - 132	14
	C3 - 135	14
107017001	S - 1-20	52
107017002	A - 36	2
107038003	C2 - 78	12
107149001	F - 5	26
	F - 13	26
	F - 37	26
107321003	A - 35	2
107321009	S - 1-19	52
107415009	B - 24	6
107415011	B - 24	6
107415014	B - 24	6
107415016	B - 24	6
107415018	B - 24	6
107415019	B - 24	6
107415021	B - 24	6
107415023	B - 24	8
107415416	Z - 17	72
107453001	D - 44	20
107606001	G - 14	28
107779001	Z - 29	72
107780001	Z - 31	72
108802001	F - 46	26

From the library of: Diamond Needle Corp

CODE	REF.NO.	Page
109239002	A - 26	2
109714000	Z - 5	72
	Z - 12	72
	Z - 21	72
109763002	L - 13	38
109893002	J - 27	32
	L - 4	38
110161004	J - 28	32
	J - 37	32
110168001	C1 - 1-11	10
110233001	J - 26	32
	J - 36	32
110367001	J - 31	32
110735001	K - 14	36
111140002	J - 50	34
111466101	D - 53	20
112738000	F - 36	26
113006001	F - 51	26
113316001	G - 5	28
114294001	G - 9	28
114483002	Z - 22	72
114486002	Z - 6	72
115186001	G - 19	28
115188001	G - 21	28
116662003	U1 - 39	56
	U2 - 39	58
117150001	F - 48	26
117291002	Y - 1-3	64
117934009	A - 5	2
	A - 6	2
	A - 11	2
	A - 20-3	2
117936001	T - 1-21	54
	T - 2-17	54
117936009	A - 42	2
	AA1- 2-5	66
118064001	Z - 33	72
118837001	Z - 27	72
119702004	U1 - 1-11	56
120438001	E - 23	22
120448001	H - 1-13	30
120990001	H - 1-14	30
122991001	Z - 14	72
123006001	B - 13-2	6
126863001	Z - 34-3	72
129986001	A - 37	2
132051001	B - 14-1-4	6
	B - 14-2-4	6
133172003	U1 - 1-3	56
133180005	U1 - 1-2-12	56
133740006	Z - 54	73
	U1 - 1-21	56
	U2 - 33	58
138444001	U1 - 41	56
	U2 - 41	58
139096001	C1 - 1-18-1	10
140392009	A - 7	2
140647101	L - 31	38
140726000	B - 5	6
141492001	J - 25-2	32
141590001	H - 1-25	30
141786001	E - 1	22
141860001	Z - 74-1-2	73

CODE	REF.NO.	Page
142443001	Z - 26	72
142721001	Z - 32	72
142990001	Z - 34-10-3	73
143591001	C1 - 1-17	10
143882001	Z - 9	72
143910009	Z - 11	72
144105000	H - 1-23	30
144110001	H - 1-21	30
144226001	Z - 50	73
144458001	B - 21	6
	K - 24	36
144504001	AA1- 1-1-2	66
	AA3- 2-1-11	70
144588001	G - 10	28
144712001	B - 2-1	6
145087001	Y - 1-1-12	64
145446001	G - 16	28
	G - 22	28
	H - 1-22	30
145472001	D - 54	20
145478101	J - 9	32
	L - 18	38
	L - 29	38
145480101	A - 25	2
145519001	G - 10	28
145547001	F - 26	26
145646011	B - 24	8
145646014	B - 24	8
145646016	B - 24	8
145646018	B - 24	8
145646019	B - 24	8
145646021	B - 24	6
145646024	B - 24	8
145646025	B - 24	8
145646421	Z - 17	72
146058001	AA1- 1-1-4	66
	AA3- 2-1-9	70
146059001	AA1- 1-1-5	66
	AA3- 2-1-8	70
146060000	AA1- 1-1-6	66
	AA3- 2-1-7	70
146080000	AA1- 1-2	66
146206009	AA1- 1-1-3	66
	AA3- 2-1-10	70
146255000	Z - 52	73
	U1 - 1-20	56
	U2 - 32	58
146256001	Z - 51	73
	U1 - 1-19	56
	U2 - 31	58
146288001	K - 18	36
146354001	C1 - 1-7	10
148196000	D - 49	20
148197000	D - 50	20
148738000	F - 4	26
148813001	J - 21-4	32
148847001	J - 12	32
149287000	P - 13	48
	AA2- 3-5	68
	AA3- 2-7	70
149482001	C1 - 4	10
149796001	N - 6	44
149809000	M - 54	41

CODE	REF.NO.	Page
149809000	P - 33	48
	P - 45	48
	S - 1-16	52
	W - 3	62
149831101	Y - 1-1-13	64
150173003	Z - 34-7	73
150174000	Z - 34-4-3	72
	Z - 34-5-1	73
150179002	Z - 34-8-1	73
150180001	Z - 34-1	72
150182000	Z - 34-2	72
150183000	Z - 34-10-2	73
150206002	Z - 34-4-1	72
150332001	Z - 103	74
150382001	Y - 1-1-5	64
150460001	D - 42	20
150461001	D - 43	20
151927001	F - 20	26
152231000	B - 10-1	6
152236001	B - 14-1-2	6
	B - 14-2-2	6
152237101	B - 14-1-3	6
152242001	B - 22	6
152243001	B - 23	6
152245001	E - 4	22
152632001	C5 - 155-1	18
152633001	C5 - 155-2	18
152678101	E - 11	22
	E - 16	22
152681201	E - 19-1	22
152682101	E - 21-1	22
152683001	E - 14-1-4	22
	E - 14-2-4	22
152684101	E - 14-1-5	22
	E - 14-2-5	22
152686101	E - 21-1	22
152869001	G - 1	28
152870001	G - 3	28
152872001	G - 8	28
152881001	G - 27	28
152883000	G - 29	28
152884001	G - 30	28
152889001	G - 23	28
	AA1- 2-4	66
152891101	G - 26	28
152938001	H - 1-17	30
152948001	F - 1	26
	F - 32	26
152969001	F - 38	26
153242000	M - 1-29-6	40
	Z - 25	72
153403002	C1 - 9	10
153484001	J - 38	32
153562001	F - 19	26
153597001	J - 21-2	32
153920001	F - 12	26
154235001	Y - 1-1-10	64
154236001	Y - 1-1-11	64
154237001	Y - 1-1-14	64
	Ga2- 1-1-14	78
154252001	Y - 1-4	64
	Ga2- 1-4	78
154253001	Y - 1-5	64

CODE	REF.NO.	Page
154253001	Ga2 - 1-5	78
154256101	Y - 1-9	64
	Ga2 - 1-9	78
154467001	Z - 4-2	72
154528001	H - 1-12	30
154596000	J - 20	32
154599000	J - 5	32
154607101	L - 9	38
154623000	B - 10-2	6
154624101	B - 14-2-3	6
154702101	Z - 23	72
154763010	B - 24	8
155167002	D - 52	20
155510001	AA1- 1-1-7	66
	AA3- 2-1-6	70
155578000	B - 19	6
156112003	Z - 34-6	73
156206001	K - 29	36
157237001	D - 64-7	20
	Ga1 - F	76
157255100	AA1- 1-1-8	66
158592001	D - 64-6	20
	Ga1 - G	76
158940001	J - 35	32
159111001	K - 37	36
159224001	G - 7	28
159574101	H - 1-19	30
159805001	G - 15	28
159905001	J - 13	32
181995001	E - 6	22
200190001	N - 15	46
	Z - 41	73
	U1 - 1-18	56
	U2 - 30	58
228475000	F - 44	26
	J - 55	34
	M - 7	40
	N - 31	44
	P - 39	48
	T - 1-11	54
	T - 2-7	54
	AA2- 4-6	68
231071001	J - 16	32
232384001	M - 1-29-3	40
340400001	P - 34	48
	P - 40	48
	Y - 1-12	64
	AA2- 3-4	68
	AA3- 2-5	70
402887001	E - 14-1-6	22
	E - 14-2-6	22
417382001	S - 1-2-5	52
525664000	P - 11	48
	P - 37	48
530138001	C3 - 108	14
	C3 - 115	14
623033000	D - 41	20
625010000	AA1- 2-2	66

CODE	REF.NO.	Page
100000001	A - 1-1	2
100000002	A - 1-2	2
100000003	A - 1-3	2
100000004	A - 1-4	2
100000005	A - 1-5	2
100000006	A - 1-6	2
100000007	A - 1-7	2
100000008	A - 1-8	2
100000009	A - 1-9	2
100000010	A - 1-10	2
100000011	A - 1-11	2
100000012	A - 1-12	2
100000013	A - 1-13	2
100000014	A - 1-14	2
100000015	A - 1-15	2
100000016	A - 1-16	2
100000017	A - 1-17	2
100000018	A - 1-18	2
100000019	A - 1-19	2
100000020	A - 1-20	2
100000021	A - 1-21	2
100000022	A - 1-22	2
100000023	A - 1-23	2
100000024	A - 1-24	2
100000025	A - 1-25	2
100000026	A - 1-26	2
100000027	A - 1-27	2
100000028	A - 1-28	2
100000029	A - 1-29	2
100000030	A - 1-30	2
100000031	A - 1-31	2
100000032	A - 1-32	2
100000033	A - 1-33	2
100000034	A - 1-34	2
100000035	A - 1-35	2
100000036	A - 1-36	2
100000037	A - 1-37	2
100000038	A - 1-38	2
100000039	A - 1-39	2
100000040	A - 1-40	2
100000041	A - 1-41	2
100000042	A - 1-42	2
100000043	A - 1-43	2
100000044	A - 1-44	2
100000045	A - 1-45	2
100000046	A - 1-46	2
100000047	A - 1-47	2
100000048	A - 1-48	2
100000049	A - 1-49	2
100000050	A - 1-50	2
100000051	A - 1-51	2
100000052	A - 1-52	2
100000053	A - 1-53	2
100000054	A - 1-54	2
100000055	A - 1-55	2
100000056	A - 1-56	2
100000057	A - 1-57	2
100000058	A - 1-58	2
100000059	A - 1-59	2
100000060	A - 1-60	2
100000061	A - 1-61	2
100000062	A - 1-62	2
100000063	A - 1-63	2
100000064	A - 1-64	2
100000065	A - 1-65	2
100000066	A - 1-66	2
100000067	A - 1-67	2
100000068	A - 1-68	2
100000069	A - 1-69	2
100000070	A - 1-70	2
100000071	A - 1-71	2
100000072	A - 1-72	2
100000073	A - 1-73	2
100000074	A - 1-74	2
100000075	A - 1-75	2
100000076	A - 1-76	2
100000077	A - 1-77	2
100000078	A - 1-78	2
100000079	A - 1-79	2
100000080	A - 1-80	2
100000081	A - 1-81	2
100000082	A - 1-82	2
100000083	A - 1-83	2
100000084	A - 1-84	2
100000085	A - 1-85	2
100000086	A - 1-86	2
100000087	A - 1-87	2
100000088	A - 1-88	2
100000089	A - 1-89	2
100000090	A - 1-90	2
100000091	A - 1-91	2
100000092	A - 1-92	2
100000093	A - 1-93	2
100000094	A - 1-94	2
100000095	A - 1-95	2
100000096	A - 1-96	2
100000097	A - 1-97	2
100000098	A - 1-98	2
100000099	A - 1-99	2
100000100	A - 1-100	2

CODE	REF.NO.	Page
100000101	A - 1-101	2
100000102	A - 1-102	2
100000103	A - 1-103	2
100000104	A - 1-104	2
100000105	A - 1-105	2
100000106	A - 1-106	2
100000107	A - 1-107	2
100000108	A - 1-108	2
100000109	A - 1-109	2
100000110	A - 1-110	2
100000111	A - 1-111	2
100000112	A - 1-112	2
100000113	A - 1-113	2
100000114	A - 1-114	2
100000115	A - 1-115	2
100000116	A - 1-116	2
100000117	A - 1-117	2
100000118	A - 1-118	2
100000119	A - 1-119	2
100000120	A - 1-120	2
100000121	A - 1-121	2
100000122	A - 1-122	2
100000123	A - 1-123	2
100000124	A - 1-124	2
100000125	A - 1-125	2
100000126	A - 1-126	2
100000127	A - 1-127	2
100000128	A - 1-128	2
100000129	A - 1-129	2
100000130	A - 1-130	2
100000131	A - 1-131	2
100000132	A - 1-132	2
100000133	A - 1-133	2
100000134	A - 1-134	2
100000135	A - 1-135	2
100000136	A - 1-136	2
100000137	A - 1-137	2
100000138	A - 1-138	2
100000139	A - 1-139	2
100000140	A - 1-140	2
100000141	A - 1-141	2
100000142	A - 1-142	2
100000143	A - 1-143	2
100000144	A - 1-144	2
100000145	A - 1-145	2
100000146	A - 1-146	2
100000147	A - 1-147	2
100000148	A - 1-148	2
100000149	A - 1-149	2
100000150	A - 1-150	2
100000151	A - 1-151	2
100000152	A - 1-152	2
100000153	A - 1-153	2
100000154	A - 1-154	2
100000155	A - 1-155	2
100000156	A - 1-156	2
100000157	A - 1-157	2
100000158	A - 1-158	2
100000159	A - 1-159	2
100000160	A - 1-160	2
100000161	A - 1-161	2
100000162	A - 1-162	2
100000163	A - 1-163	2
100000164	A - 1-164	2
100000165	A - 1-165	2
100000166	A - 1-166	2
100000167	A - 1-167	2
100000168	A - 1-168	2
100000169	A - 1-169	2
100000170	A - 1-170	2
100000171	A - 1-171	2
100000172	A - 1-172	2
100000173	A - 1-173	2
100000174	A - 1-174	2
100000175	A - 1-175	2
100000176	A - 1-176	2
100000177	A - 1-177	2
100000178	A - 1-178	2
100000179	A - 1-179	2
100000180	A - 1-180	2
100000181	A - 1-181	2
100000182	A - 1-182	2
100000183	A - 1-183	2
100000184	A - 1-184	2
100000185	A - 1-185	2
100000186	A - 1-186	2
100000187	A - 1-187	2
100000188	A - 1-188	2
100000189	A - 1-189	2
100000190	A - 1-190	2
100000191	A - 1-191	2
100000192	A - 1-192	2
100000193	A - 1-193	2
100000194	A - 1-194	2
100000195	A - 1-195	2
100000196	A - 1-196	2
100000197	A - 1-197	2
100000198	A - 1-198	2
100000199	A - 1-199	2
100000200	A - 1-200	2

From the library of: Diamond Needle Corp